

ACTUATOR

SLIDE GUIDE

BALL SPLINE
ROTARY BALL SPLINE

TOPBALL® PRODUCTS

SLIDE BUSH

SLIDE UNIT

STROKE BUSH
SLIDE ROTARY BUSH

SLIDE SHAFT

SLIDE WAY
SLIDE TABLE
GONIO WAY

ACTUATOR

SLIDE SCREW



ACTUATOR

NB's BG type is a compact single axis actuator which integrates a slide guide and precision ball screw.

BG type offers compact dimensions and outperforms conventional positioning tables. This is made possible by a unique "U" shaped guide rail and slide block which provides multiple functions of a guide block and a ball screw nut combined into a single unit. The "U" shaped guide rail design offers a high rigid structure resistant to bending. This structural feature allows for integrated framework of machinery or equipment and may be one-end supported. Additionally, the slide block contains 4 ball circuits which delivers high load capacity, high accuracy and high rigidity.

Figure I-1 Structure of BG type

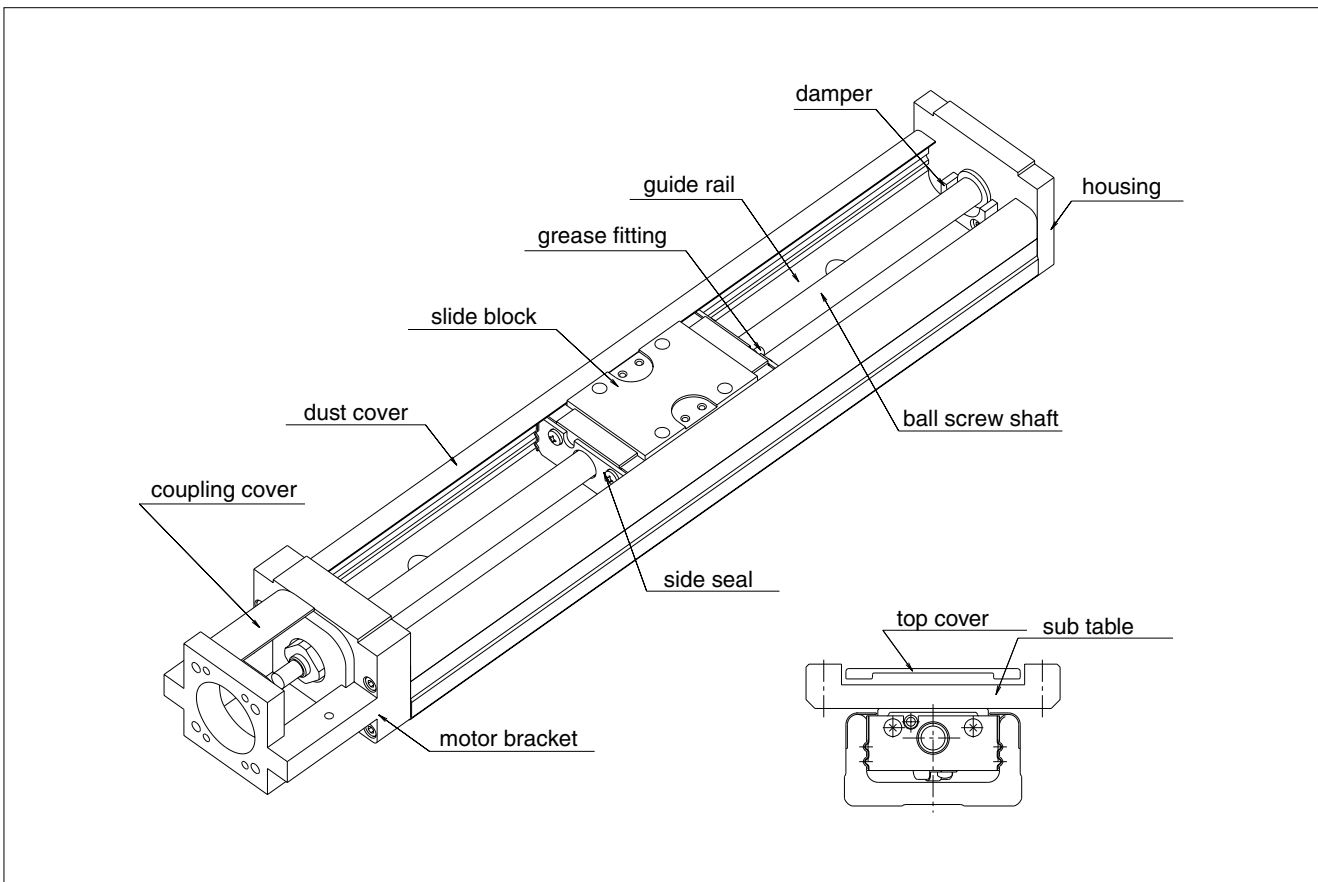

ADVANTAGES

Adjustment Free:

The integration of the slide guide and precision ball screw eliminates complex precision adjustment and reduces installation time dramatically.

High Rigidity:

"U" shaped guide rail provides very high rigidity despite its compact configuration and can be used for one-end supported application.(Reference Page I-20)

High Accuracy:

BG type contains four ball circuits and four-point contact ball grooves which contributes to its high rigidity. The combination of precision ground guide rail, slide block and precision ball screw provides high positioning accuracy.

Space Saving:

In comparison to conventional positioning tables, the BG type allows for compact designs and dramatic space saving. The "U" shaped guide rail and integrated slide block / precision ball screw nut make this possible.

Figure I-2 Ball Contact View

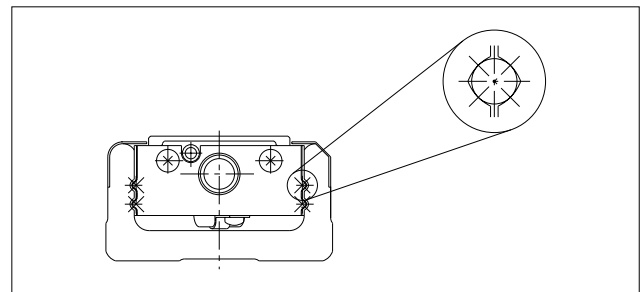
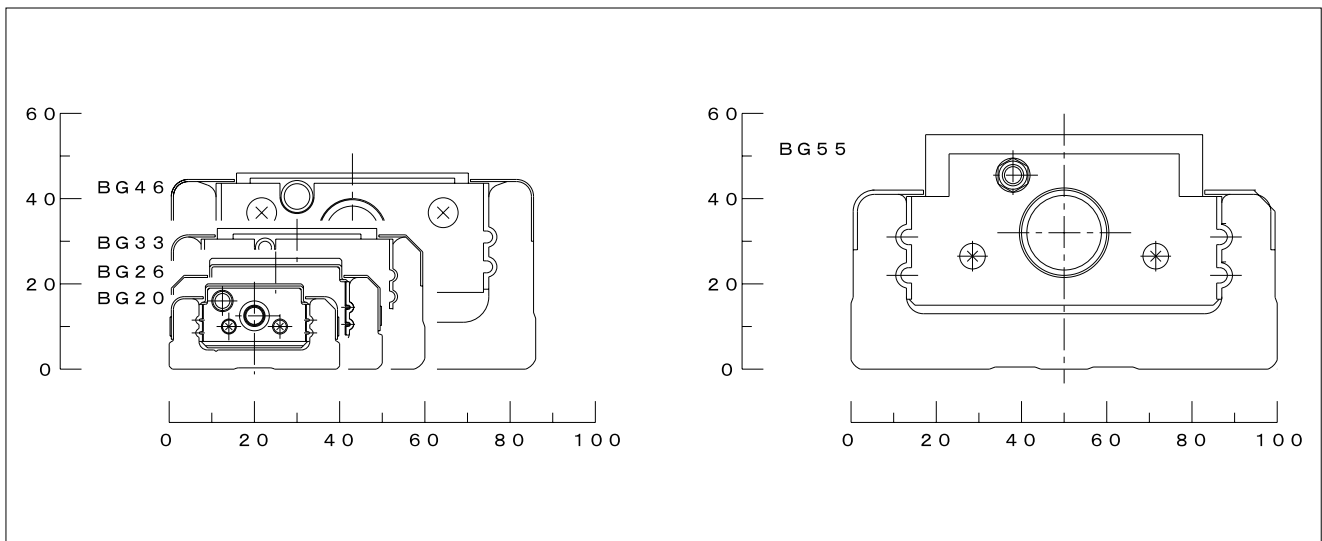

Figure I-3 Cross Sectional View





PART NUMBER SYSTEM

Part number for BG type is described as follows.

①	②	③	④	⑤	⑥	⑦	⑧	⑨	⑩
BG	20	01	A	100	H	A0			GK
			B	150	P	A1	C	S	RD
				200		A2		K	GKRD
						A3			
						A4			
						A5			
						A6			
						A7			

①	②	③	④	⑤	⑥	⑦	⑧	⑨	⑩
BG	26	02	A	150	H	A0			GK
			B	200	P	A1	C	S	RD
				250		A2		K	GKRD
				300		A3			
						A4			
						A5			
						A6			
						A7			

①	②	③	④	⑤	⑥	⑦	⑧	⑨	⑩
BG	33	05	A	150	H	A0			GK
		10	B	200	P	A1	C	S	RD
			C	300		A2			GKRD
			D	400		A3			
				500		A4			
				600		A5			
						B1			
						R0			
						RA			
						RB			

①	②	③	④	⑤	⑥	⑦	⑧	⑨	⑩
BG	46	10	A	340	H	A0			GK
		20	B	440	P	A1	C	S	RD
			C	540		A2			GKRD
			D	640		A3			
				740		B0			
				840		C0			
				940		D0			
						R0			
						RA			
						RB			
						RC			

①	②	③	④	⑤	⑥	⑦	⑧	⑨	⑩
BG	55	20	A	980	H	A0			GK
			B	1080	P	A1	C	S	RD
				1180		A2			GKRD
				1280		A3			
				1380		A4			
						A5			

① BG type

② size

③ ball screw lead

④ type of block

A	with 1 long block
B	with 2 long blocks *
C	with 1 short block
D	with 2 short blocks *

* Driver block is located closest to motor mount bracket side.

⑤ guide rail length

⑥ precision grade

none	high grade
P	precision grade

⑦ motor bracket (refer to page I-8)

The number in the square, □, after suffix RA, RB or RC indicates the mounting direction.

⑧ top-cover

none	without top-cover
C	with top-cover *

* top-cover and auxiliary table.

⑨ photo-sensor

none	without sensor
S	with sensor
K	with proximity sensor (BG20, 26)

⑩ surface treatment and special grease

none	without surface treatment + standard grease
GK	K-grease (low dust generation lubricant)
RD	Raydent treatment
GKRD	K-grease + Raydent treatment

※1:K-grease is applied into the portion of guide, ball screw and augular bearing. Please refer to P.Eng-12 for details of K-grease.

※2:Raydent treatment is only a steel portion without radial bearing.

SPECIFICATION

BG Type is categorized as either high grade or precision grade (P).

Table I-1 Specification

part number			BG2001		BG2005		BG2602		BG2605		BG3305		BG3310		BG4610		BG4620		BG5520											
precision grade			high	%precision	high	%precision	high	%precision	high	%precision	high	precision	high	precision	high	precision	high	precision	high	precision										
guide	radial clearance	μm	-3~0	-6~-3	-3~0	-6~-3	-4~0	-8~-4	-4~0	-8~-4	-3~0	-7~-3	-3~0	-7~-3	-5~0	-11~-5	-5~0	-11~-5	-6~0	-18~-6										
		basic dynamic load	C	kN	4.10				7.91				11.8				27.0				36.8									
	long block	basic static load	Co	kN	6.90				13.1				19.9				45.0				61.4									
			allowable static moment	MP	N·m	32				93				169				572				910								
		M2P		N·m	194				560				1,014				3,432				5,460									
		MY		N·m	38				111				201				681				1,080									
		M2Y		N·m	231				667				1,206				4,086				6,480									
		MR	N·m	88				224				411				1,410				2,230										
	short block	basic dynamic load	C	kN	-				-				5.90				13.5				-									
			Co	kN	-				-				9.90				22.5				-									
		allowable static moment	MP	N·m	-				-				42				143				-									
			M2P	N·m	-				-				252				858				-									
			MY	N·m	-				-				49				169				-									
			M2Y	N·m	-				-				294				1,014				-									
MR	N·m	-				-				205				705				-												
ball screw	shaft diameter	mm	6				8				10				15				20											
	lead	mm	1				2				5		10		10		20		20											
	spacer-ball ratio	-	-				-				-		1:1		-		1:1		-		2:1		-		2:1					
	basic dynamic load	Ca	kN	0.63				2.60				3.35		2.11		2.20		1.39		4.40		2.77		4.40		3.36		5.40		4.12
basic static load	Coa	kN	1.34				3.64				5.90		2.95		3.50		1.75		7.90		3.95		7.90		5.27		10.50		7.00	
bearing support	part Number	-	AC5-14DF				AC6-16DF				70M8DF/GMP5				7001T2DF/GMP5				7002T2DF/GMP5											
	basic dynamic load	Cb	kN	0.696				1.38				4.40				6.77				7.74										
	basic static load	Cob	kN	0.304				1.76				4.36				7.45				9.50										

M_{2P} and M_{2Y} account for the allowable static moment when 2 blocks are used together. (As shown in Figure I-4)

Please contact NB for details when using BG20 & BG26-P grade series with short and frequent stroke. (Stroke distance : BG2001 = 7 mm or less, BG2005 = 25 mm or less, BG2602 = 14 mm or less and BG2605 = 25 mm or less)

Figure I-4 Direction of Moment

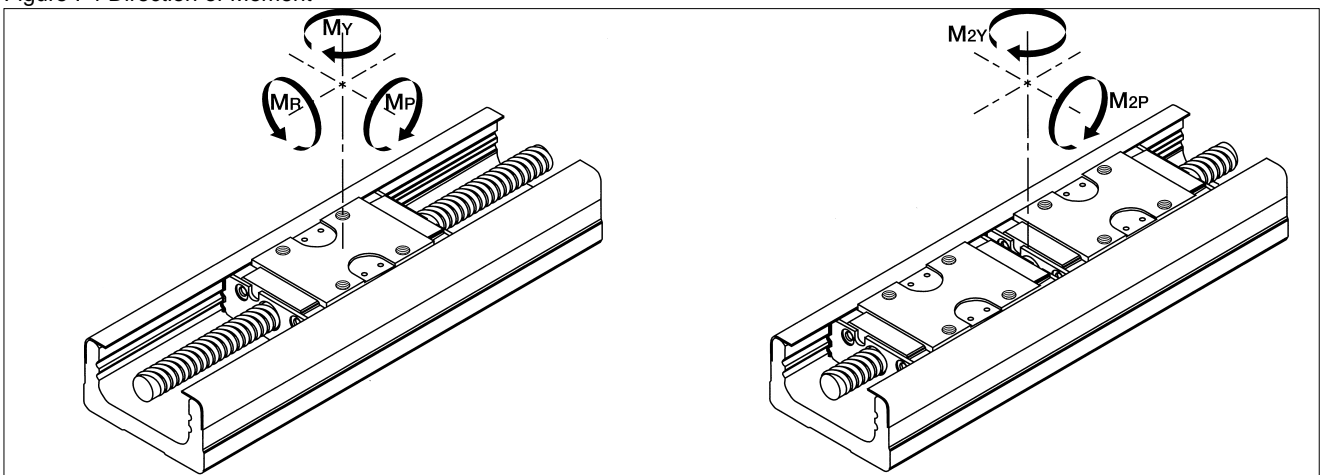



ACCURACY

Table 2 shows accuracy of BG type.

Table I-2 Accuracy

part number	rail length	positioning repeatability μm		positioning accuracy μm		running parallelism μm		backlash μm		※starting torque N · m		
		high	precision	high	precision	high	precision	high	precision	high	precision	
BG 20	100	±5	±3	50	20	25	10	10	3	0.005	0.012	
	150											
	200											
BG 26	150	±5	±3	50	20	25	10	10	3	0.015	0.04	
	200											
	250											
	300											
BG 33	150	±5	±3	30	15	25	10	10	3	0.07	0.15	
	200											
	300			35	20							
	400			40	25	35	15					
	500			-	70							-
	600											
BG 46	340	±5	±3	35	20	35	15	10	3	0.10	0.15	
	440											
	540			40	25							
	640			50	30	40	20					
	740			-	90	-	50				-	-
	840											
	940											
BG 55	980	±5	±5	80	35	50	25	50	3	0.12	0.17	
	1,080			100	40		30				0.20	
	1,180		-		100		-				-	-
	1,280											
	1,380											

Above values are measured in conditions using our selected motors.

※Above specifications are based on using NB standard grease. other grease may cause deviations.

Positioning Repeatability:

Establish an arbitrary point. From one end, position the inner block at this point and measure the stop position. Repeat the positioning and measurement process 7 times. Repeat the same process with respect to the established set point at the midpoint and near both ends of travel. Take the maximum measurement and divide the maximum difference by 2 and indicate it with either a positive or negative sign as the test results.

Positioning Repeatability=
 $\pm 1/2\{(\text{Maximum value of } \ell_n) - (\text{Minimum value of } \ell_n)\}$

Positioning Accuracy:

Positioning is performed in only one direction and the resulting position is set as the reference measurement point. Calculate the difference between the length of actual travel and the commanded travel length. Continuing in the same direction (without returning to the start point) repeat this process randomly several times until reaching limit of full stroke. Express the accuracy by the absolute maximum difference.

Positioning accuracy = $(\Delta \ell_n)_{\max}$

Running Parallelism:

Making sure that the surface plate is absolutely flat. Use the test indicator as shown in Figure I-7, run the block over the entire length of travel and use the maximum difference in readings as the test results.

Backlash:

Use the feed screw to move the block a little. Take the test indicator reading and make it the reference point. While in this position, load the block in the same direction without using the feed screw. Release the load and read the return. Calculate the difference between the reference point. Repeat the same process at the midpoint and near both ends. Use the maximum difference as the test result.

Backlash = $(\Delta \ell)_{\max}$

Figure I-5 Positioning Repeatability

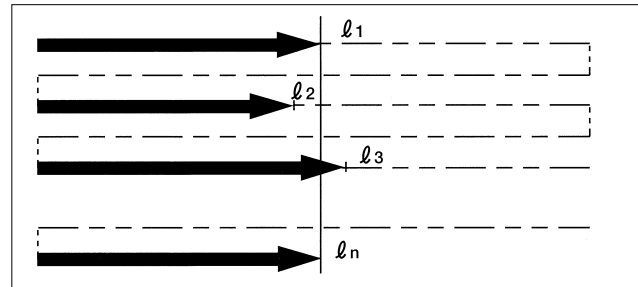

Figure I-6 Positioning Accuracy

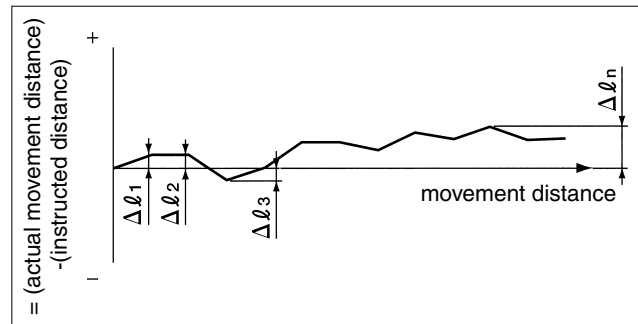

Figure I-7 Running Parallelism

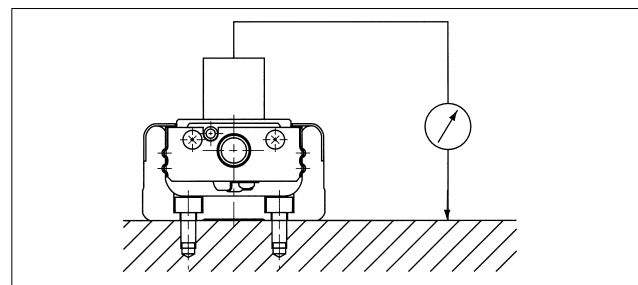
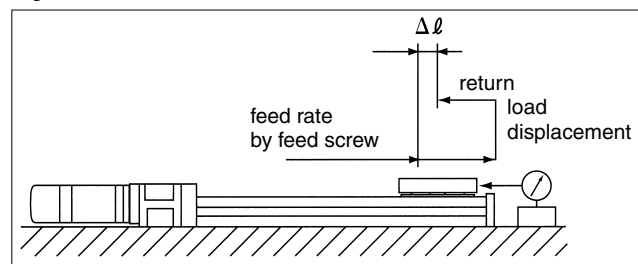

Figure I-8 Backlash





MOTOR BRACKET CONFIGURATIONS & APPLICABLE MOTORS

NB provides optional motor mount brackets to easily install most popular motors.

Table I-3 Applicable motors

Applicable motors			Part number	BG20	BG26	BG33	BG46	BG55	
AC Servo motor	MATSUSITA ELECTRIC	MSM5BZ21A	5W	A2	A2	—	—	—	
		MSM1AZ21A	10W						
		MSM2AZ21A	20W						
			MSMA3AZ	30W	A3	A3	A2	C0	—
			MSMA5AZ	50W					
			MSMA01	100W					
			MSMA02	200W					
			MSMA04	400W	—	—	—	A2	—
		MSMA08	750W	—	—	—	—	A2	
	MITSUBISHI ELECTRIC	HC-KFS(MFS,PQ)053	50W	A1	A1	A1	B0	—	
		HC-KFS(MFS,PQ)13	100W						
		HC-KFS(MFS,PQ)23	200W	—	—	—	A1	A0	
		HC-KFS(MFS,PQ)43	400W	—	—	—	—	A1	
		HA-FF053	50W	—	—	A3	A0	—	
		HA-FF13	100W	—	—	—	A3	A2	
		HA-FF23	200W	—	—	—	—	—	
		HA-FF33	300W	—	—	—	—	—	
	YASUKAWA ELECTRIC	SGMAH(SGML)-A3	30W	A1	A1	A1	B0	—	
		SGMAH(SGML)-A5	50W						
		SGMAH(SGML)-01	100W	—	—	—	A1	A0	
		SGMAH(SGML)-02	200W						
		SGML-03	300W						
		SGMAH(SGML)-04	400W						
		SGMAH-08	750W	—	—	—	—	A1	
	SANYO ELECTRIC	P30B04003	30W	A1	A1	A1	B0	—	
		P30B04005	50W						
		P30B04010	100W						
		P30B06020	200W	—	—	—	A1	A0	
		P30B06040	400W	—	—	—	—	A1	
		P30B08075	750W	—	—	—	—	—	
		P50B05005	50W	—	—	A3	A0	—	
		P50B05010	100W						
		P50B07020	200W						
		P50B07030	300W						
		P50B07040	400W						
		P50B08050	500W	—	—	—	—	A3	
P50B08075	750W	—	—	—	—	—			
CHIBA PRECISION	EA-2151	6W	A4	—	—	—	—		
	EA-2169	10W							
	EA-2565	12W	A7	A7	—	—	—		
	EA-2580	20W							
Stepper motor	ORIENTAL MOTOR	UPD534M-A	—	A5	A5	—	—	—	
		PMU33AH	—	A6	A6	—	—	—	
		UPK(RK)54,AS4	—	A5	A5	B1	—	—	
		UPK(RK)56,AS6	—	—	—	A4	D0	—	
		UPK(RK)59,AS9	—	—	—	—	—	A4	
		PK26	—	—	—	A5	—	—	

NB can provide other motor mount brackets. Please contact your NB representative for details.

BG20

Figures inside() indicates mass of the motor mount adapter plate.

Motor Bracket A0

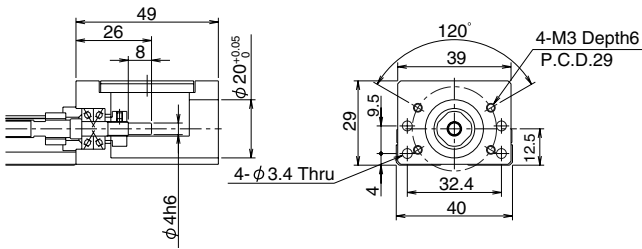

Motor Bracket A4 (Mass: 5 g)

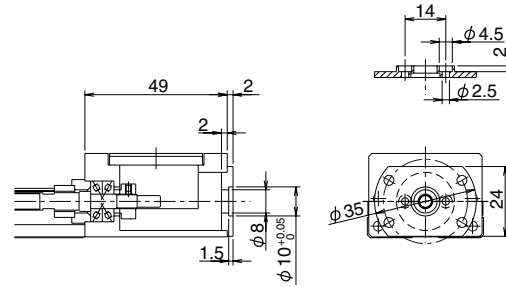

Motor Bracket A1 (Mass:38 g)

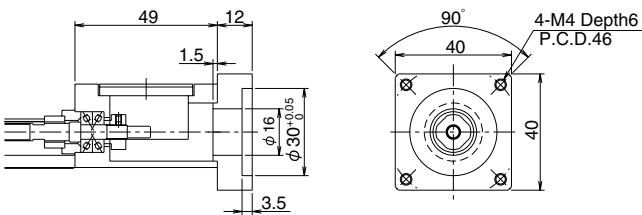

Motor Bracket A5 (Mass:26 g)

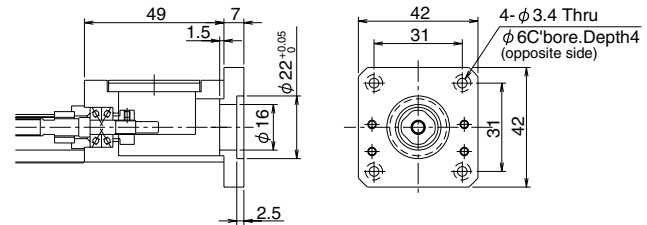

Motor Bracket A2 (Mass:14 g)

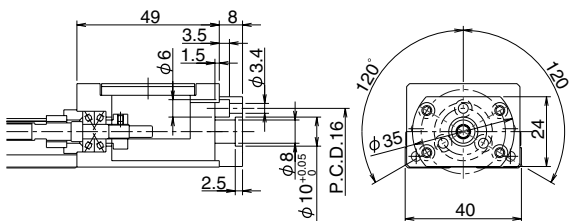

Motor Bracket A6 (Mass:10 g)

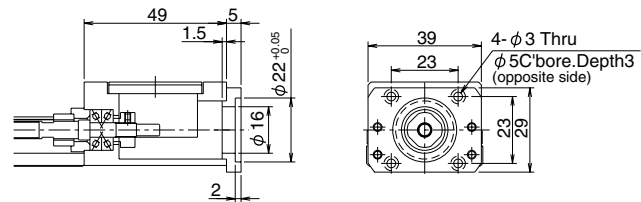

Motor Bracket A3 (Mass:39 g)

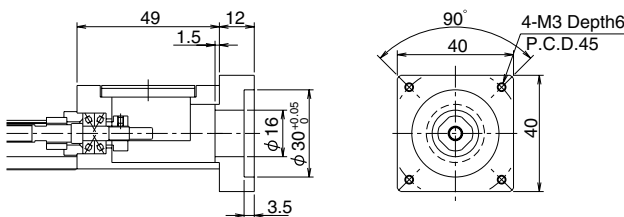

Motor Bracket A7 (Mass: 8 g)

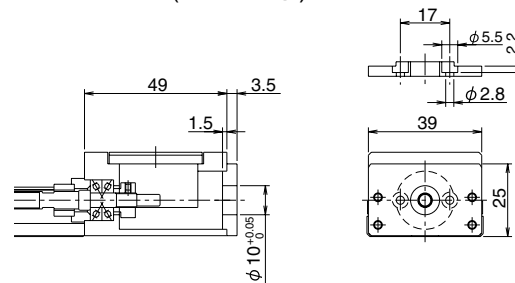

For configurations A2, A4, A5, A6 and A7, the motor mount adapter plate is required to fit after motor is mounted.

SLIDE GUIDE
BALL SPLINE
ROTARY BALL SPLINE
TOPBALL® PRODUCTS
SLIDE BUSH
SLIDE UNIT
STROKE BUSH
SLIDE ROTARY BUSH
SLIDE SHAFT
SLIDE WAY
SLIDE TABLE
GNONIO WAY
ACTUATOR
SLIDE SCREW



BG26

Figures inside() indicates mass of the motor mount adapter plate.

Motor Bracket A0

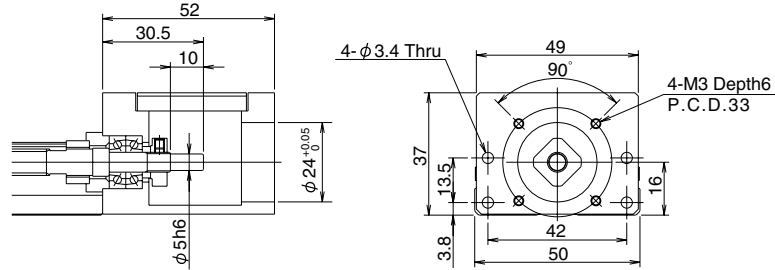

Motor Bracket A1 (Mass:28 g)

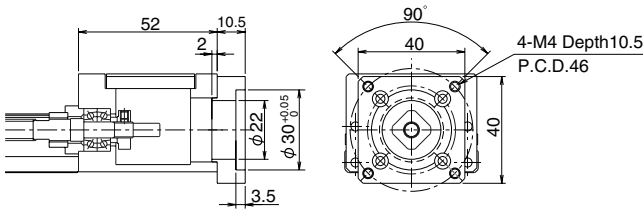

Motor Bracket A5 (Mass:32 g)

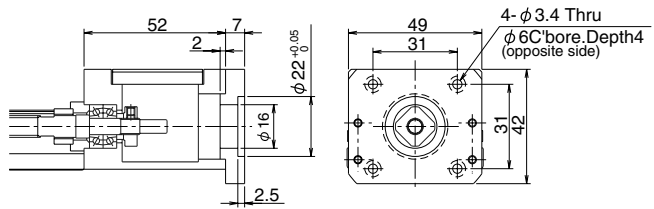

Motor Bracket A2 (Mass:12 g)

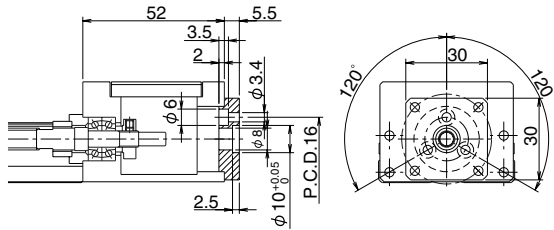

Motor Bracket A6 (Mass:16 g)

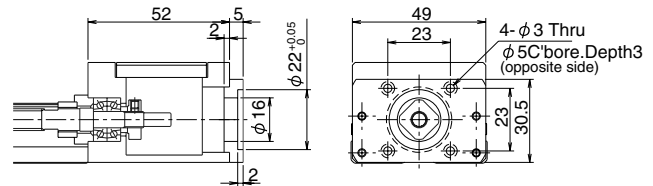

Motor Bracket A3 (Mass:24 g)

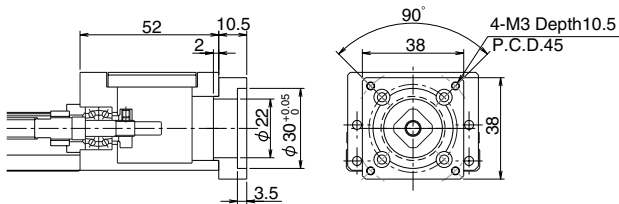

Motor Bracket A7 (Mass: 8 g)

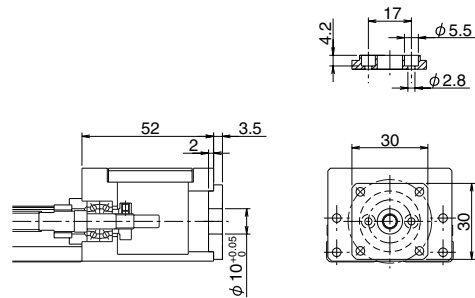

For configurations A2, A5, A6 and A7, the motor mount adapter plate is required to fit after motor is mounted.

BG33

Figures inside() indicates mass of the motor mount adapter plate.

Motor Bracket A0

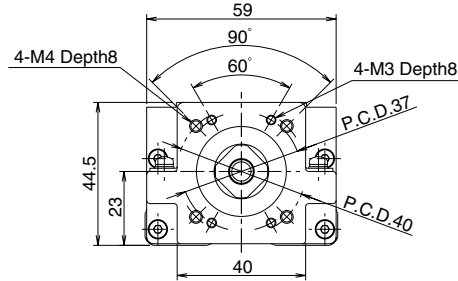
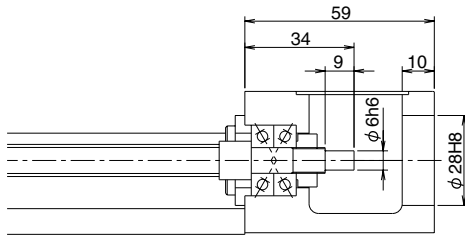

Motor Bracket A1 (Mass:66 g)

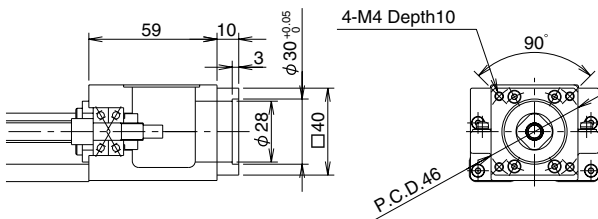

Motor Bracket A4 (Mass:212 g)

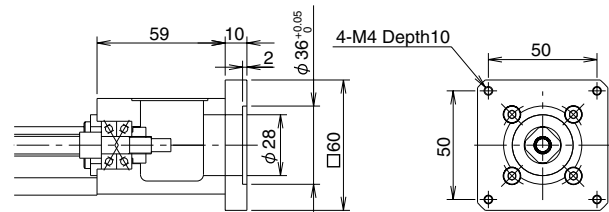

Motor Bracket A2 (Mass:67 g)

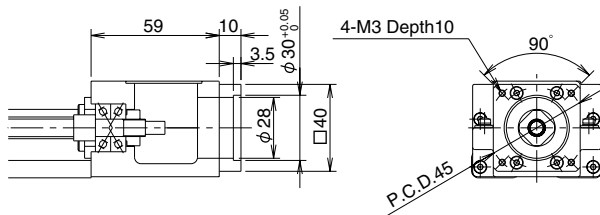

Motor Bracket A5 (Mass:125 g)

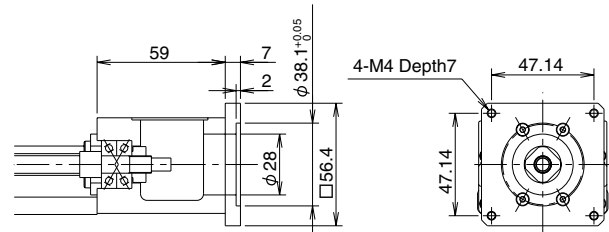

Motor Bracket A3 (Mass:133 g)

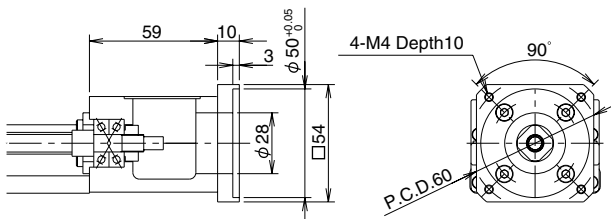

Motor Bracket B1 (Mass:111 g)

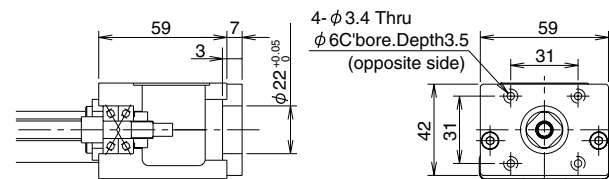

For configuration of B1, the motor mount adapter plate is required to fit after motor is mounted.



BG46

Figures inside() indicates mass of the motor mount adapter plate.

Motor Bracket A0

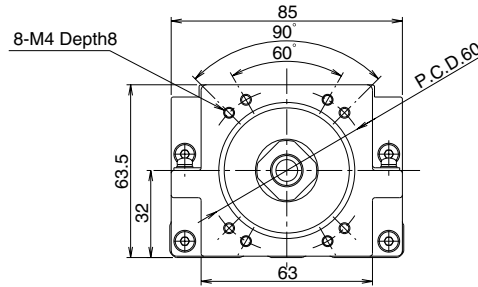
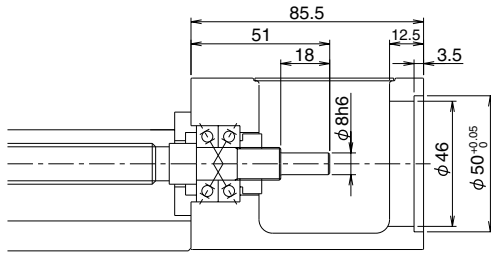

Motor Bracket A1 (Mass:103 g)

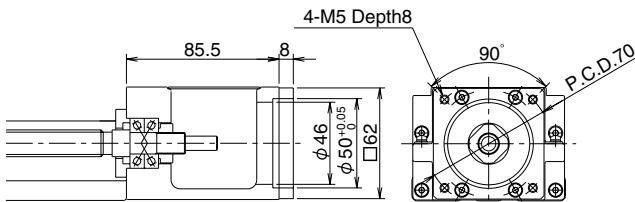

Motor Bracket B0

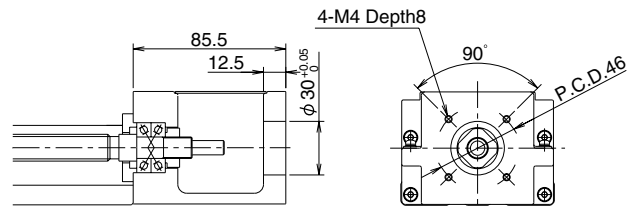

Motor Bracket A2 (Mass:106 g)

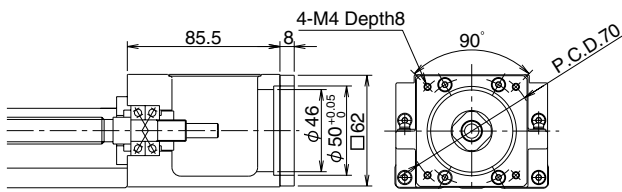

Motor Bracket C0

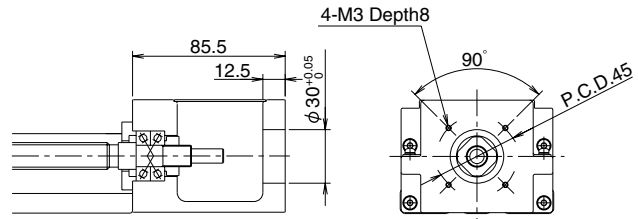

Motor Bracket A3 (Mass:448 g)

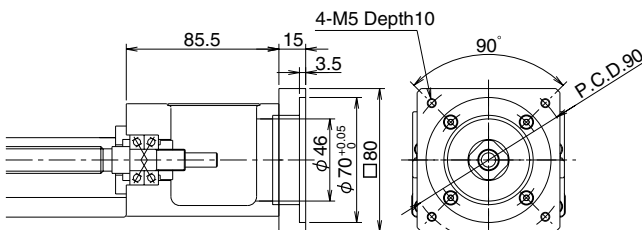

Motor Bracket D0

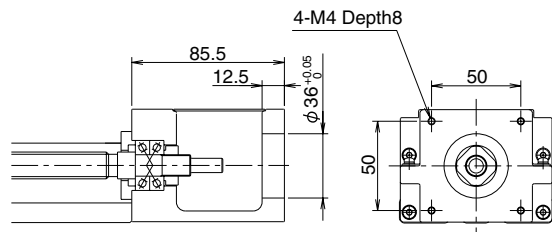

BG55

Figures inside() indicates mass of the motor mount adapter plate.

Motor Bracket A0

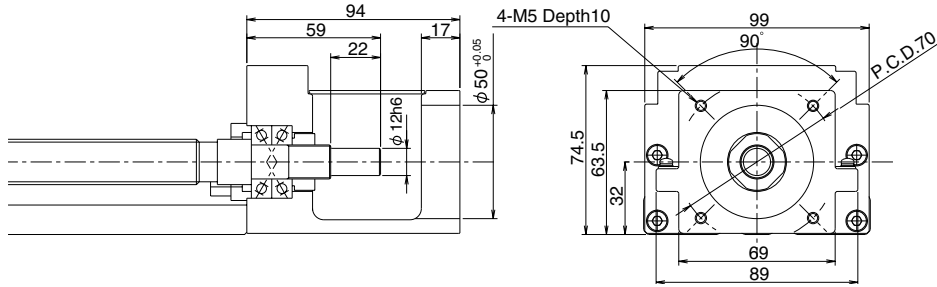

Motor Bracket A1 (Mass:329 g)

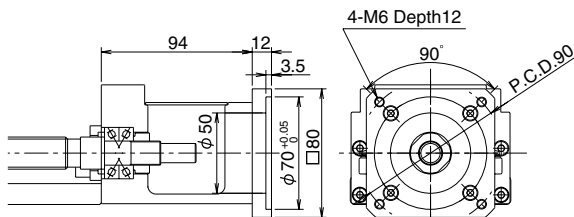

Motor Bracket A5 (Mass:399 g)

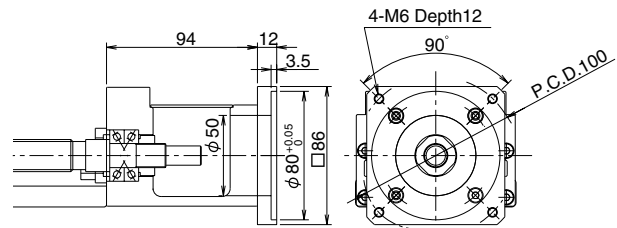

Motor Bracket A2 (Mass:333 g)

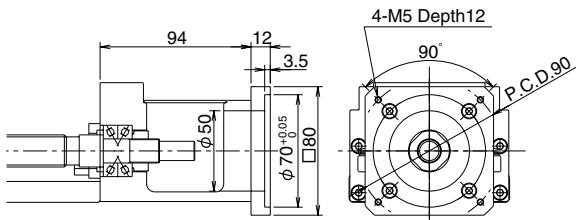

Motor Bracket A6 (Mass:449 g)

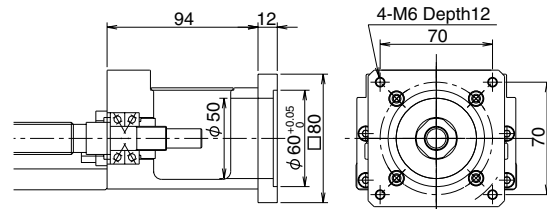



<BG33 Return Bracket R0>

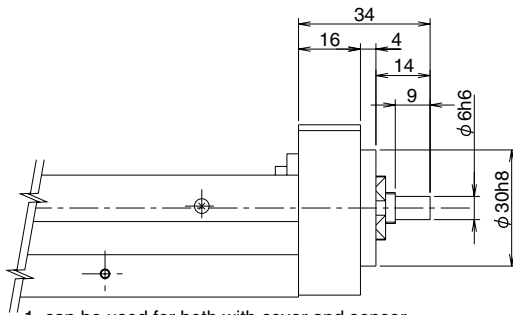

1. can be used for both with cover and sensor.
2. Mass is reduced 0.1kg from the value of Table H-7, page I-18.

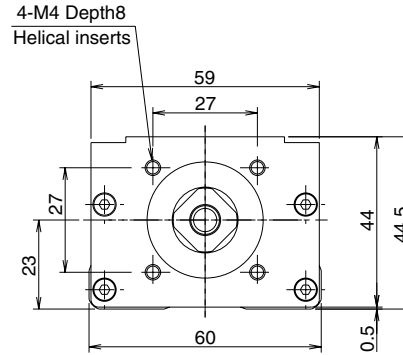

<BG33 Return Pulley Unit>

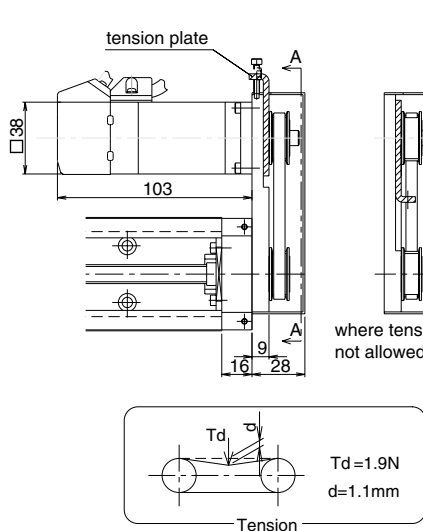

where tension plate is not allowed to be exposed

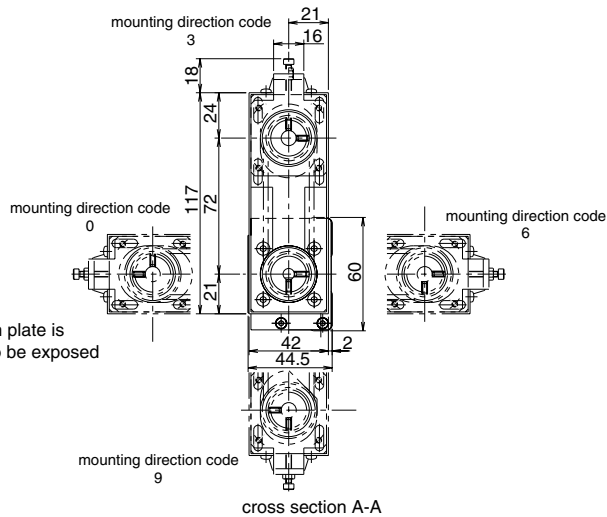

cross section A-A

1. This drawing shows RA for MSMA01 (Panasonic).
2. Installation position of Pulley Unit can be selected at 90° intervals (mounting direction code).
3. Can be used for both with or without cover and / or sensor.
4. Tension plate can be built in and is not exposed.
5. Mass is added 0.2kg to the value of Table I-7, page I-18.
6. Inertia is added $2.22 \times 10^{-6} \text{kg} \cdot \text{m}^2$ to the value of Table I-9, page I-19.
7. part number format

BG33*—*****/**

Symbol of applicable motor bracket
(see page I-4)

Mounting direction code
(refer to cross section A-A)

Table I-4 Motor Bracket Configurations

Motor Bracket	Applicable Motors
RA	MATSUSITA ELECTRIC INDUSTRIAL MINAS SERIES :50~100W
RB	YASUKAWA ELECTRIC SIGMA SERIES :50~100W
	MITSUBISHI ELECTRIC HC-MF SERIES :50~100W
	SANYO ELECTRIC P3 SERIES :50~100W

Please contact NB for return brackets for other stepper motors.

<BG46 Return Bracket R0>

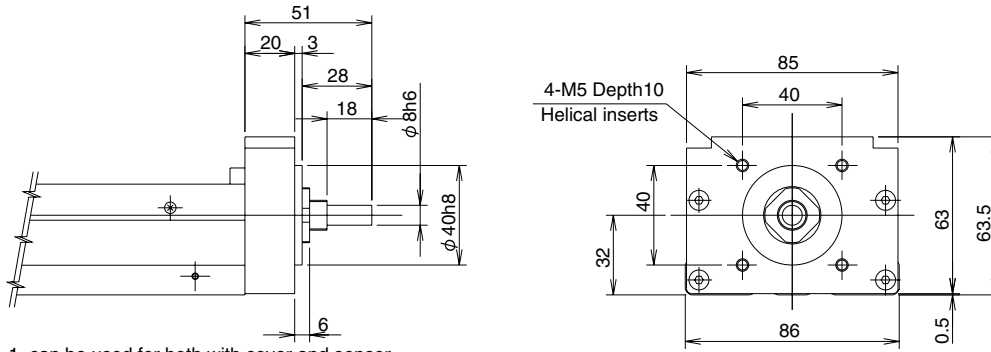

1. can be used for both with cover and sensor.
2. Mass is reduced 0.3kg from the value of Table I-7, I-18.

<BG46 Return Pulley Unit>

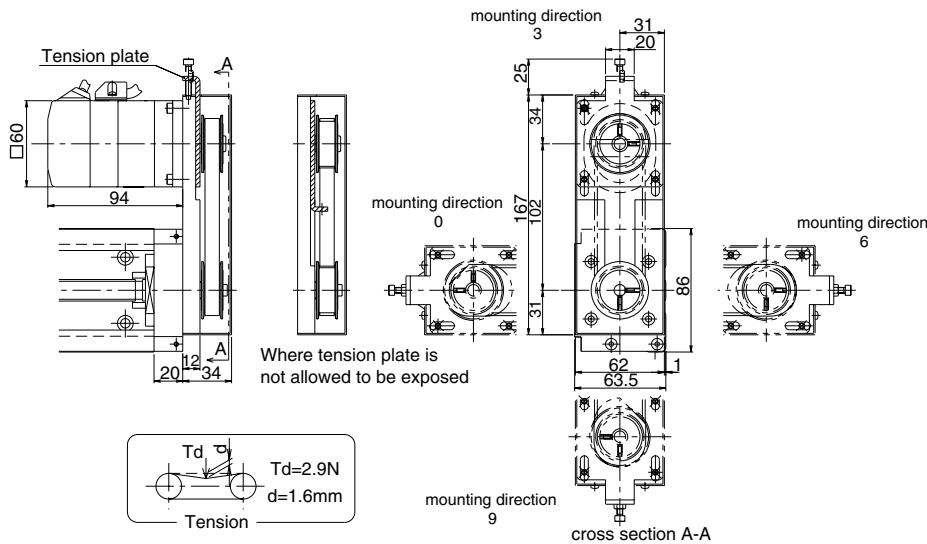

- 1.This drawing shows RA for MSMA01(Panasonic).
- 2.Installation position of Pulley Unit can be selected at 90° intervals (mounting direction code).
- 3.Can be used for both with or without cover and / or sensor.
- 4.Tension plate can be built in and is not exposed.
- 5.Mass is added 0.7kg to the value of Table I-7, page I-18.
- 6.Inertia is added $1.24 \times 10^{-5} \text{kg} \cdot \text{m}^2$ to the value of Table I-9, page I-19.
- 7.parts number format

BG33*—*****/**

Symbol of applicable motor bracket
(see page 4)

Mounting direction code
(refer to cross section A-A)

Table I-5 Motor Bracket Configurations

Motor Bracket	Applicable Motors
RA	MATSUSITA ELECTRIC INDUSTRIAL MINAS SERIES : 200W
RB	YASUKAWA ELECTRIC SIGMA SERIES : 200W
	MITSUBISHI ELECTRIC HC-MF SERIES : 200W
	SANYO ELECTRIC P3 SERIES : 200W
RC	ORIENTAL MOTOR STEPPER MOTOR □60 SERIES

Please contact NB for return brackets for other stepper motors.



SENSOR

Photo-sensor or proximity-sensor may be attached to the BG actuator with our optional sensor-mounting rail. Tapped holes are machined on both side of guide rail, allowing attachment of sensor to either side. Standard positioning (without special instruction from customer) would be to the left of the motor mount end. Sensor option includes the items that are listed below.

Figure I-9 sensor specifications

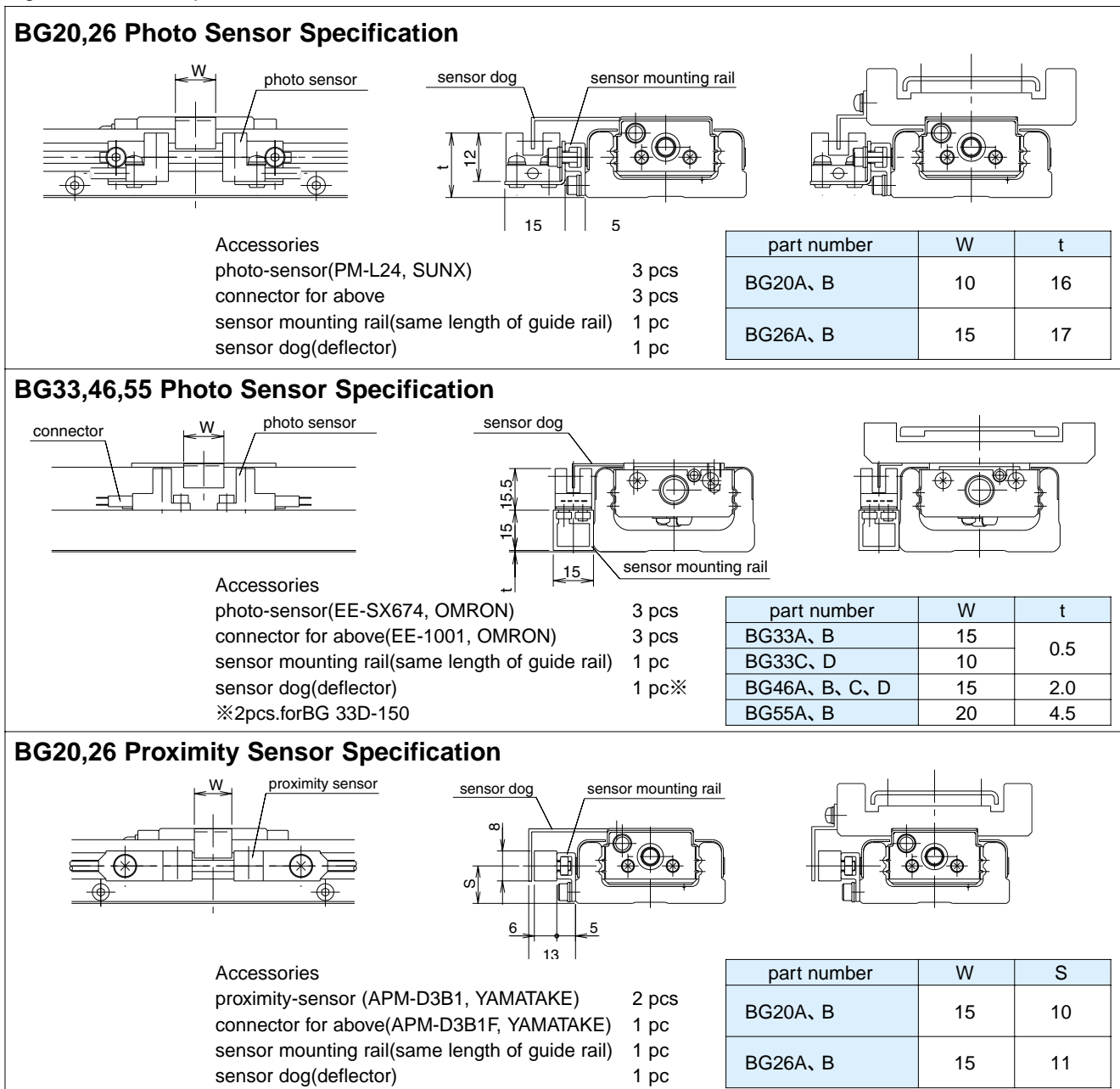

ALLOWABLE SPEED

Allowable speed of BG type is subject to the type of motor and operating conditions. The speed may also be limited by the critical speed of the ball screw. Use caution when operating at high speeds or using long rails.

Table I-6 Allowable Speed

part number	rail length mm	speed mm/sec
BG2001	100	187
	150	
	200	
BG2602	150	281
	200	
	250	
BG3305	150	550
	200	
	300	
	400	460
	600	310
BG3310	150	1,100
	200	
	300	
	400	930
	600	620

part number	rail length mm	speed mm/sec
BG4610	340	740
	440	
	540	
	640	
	740	
BG4620	740	650
	840	500
	940	390
	340	1,480
	440	
	540	
640		
740		
BG5520	840	1,300
	940	1,000
	980	780
	1,080	1,120
	1,180	910
	1,280	750
1,380	630	
	1,380	530

Figure I-10 Guide Rail Length and Allowable Speed

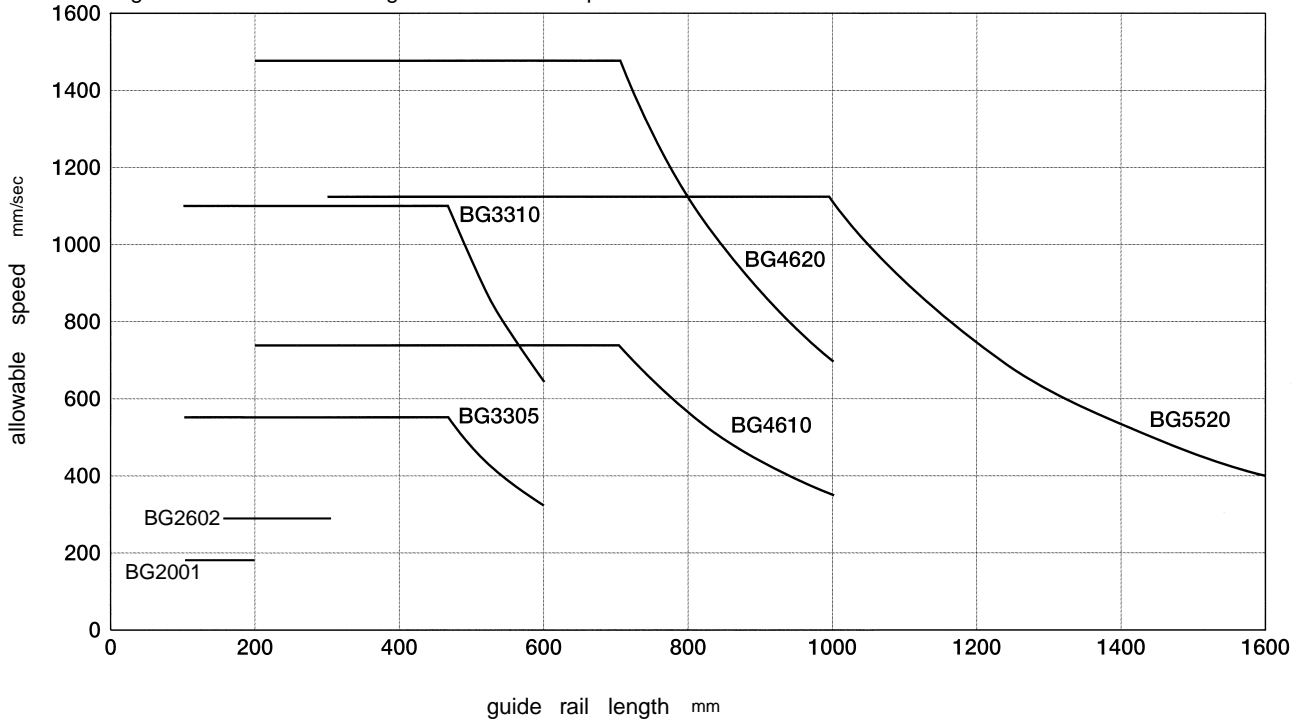



MASS

The mass of the BG type is listed in Table I-7 and slide block mass is listed in Table I-8.

Table I-7 Mass of BG type Actuator

unit / kg

part number	rail length mm	without top-cover				with top-cover				rail length mm
		long block		short block		long block		short block		
		1block A	2block B	1block C	2block D	1block A	2block B	1block C	2block D	
BG20	100	0.45	0.52	—	—	0.50	0.61	—	—	100
	150	0.58	0.65	—	—	0.63	0.74	—	—	150
	200	0.71	0.78	—	—	0.77	0.88	—	—	200
BG26	150	0.93	1.10	—	—	1.07	1.31	—	—	150
	200	1.14	1.31	—	—	1.30	1.54	—	—	200
	250	1.36	1.53	—	—	1.53	1.78	—	—	250
	300	1.57	1.74	—	—	1.76	2.01	—	—	300
BG33	150	1.6	—	1.5	1.7	1.8	—	1.6	1.9	150
	200	2.0	—	1.8	2.0	2.1	—	2.0	2.2	200
	300	2.6	2.9	2.5	2.7	2.8	3.2	2.6	2.9	300
	400	3.2	3.6	3.1	3.3	3.5	3.9	3.3	3.5	400
	500	3.9	4.2	3.8	3.9	4.2	4.6	4.0	4.2	500
	600	4.6	4.9	4.4	4.6	4.9	5.3	4.7	4.9	600
BG46	340	6.5	7.5	6.0	6.5	7.0	8.0	6.5	7.0	340
	440	8.0	8.5	7.5	8.0	8.5	9.5	8.0	8.5	440
	540	9.0	10.0	8.5	9.5	10.0	11.0	9.5	10.0	540
	640	10.5	11.5	10.0	10.5	11.0	12.5	10.5	11.5	640
	740	12.0	13.0	11.5	12.0	12.5	14.0	12.0	13.0	740
	840	13.0	14.0	13.0	13.5	14.0	15.5	13.5	14.0	840
	940	14.5	15.5	14.0	14.5	15.5	16.5	15.0	15.5	940
BG55	980	20	22	—	—	21	24	—	—	980
	1,080	22	24	—	—	23	26	—	—	1,080
	1,180	23	25	—	—	25	27	—	—	1,180
	1,280	25	27	—	—	27	29	—	—	1,280
	1,380	27	29	—	—	29	31	—	—	1,380

Table I-8 Mass of Blocks

unit / kg

part number	without top-cover		with top-cover	
	long block	short block	long block	short block
BG20	0.07	—	0.11	—
BG26	0.17	—	0.24	—
BG33	0.3	0.15	0.4	0.2
BG46	0.9	0.5	1.2	0.7
BG55	1.7	—	2.3	—

Mass stated "with top-cover" includes mass of auxiliary table.

INERTIA

Inertia of the slide block and ball screw of BG type are shown in Table I-9.

Table I-9 Inertia

unit / kg·m²

part number	rail length mm-7	without top-cover				with top-cover				rail length mm
		long block		short block		long block		short block		
		1block A	2block B	1block C	2block D	1block A	2block B	1block C	2block D	
BG2001	100	1.34 × 10 ⁻⁷	1.36 × 10 ⁻⁷	—	—	1.36 × 10 ⁻⁷	1.40 × 10 ⁻⁷	—	—	100
	150	1.83 × 10 ⁻⁷	1.85 × 10 ⁻⁷	—	—	1.85 × 10 ⁻⁷	1.89 × 10 ⁻⁷	—	—	150
	200	2.33 × 10 ⁻⁷	2.35 × 10 ⁻⁷	—	—	2.35 × 10 ⁻⁷	2.39 × 10 ⁻⁷	—	—	200
BG2602	150	6.08 × 10 ⁻⁷	6.26 × 10 ⁻⁷	—	—	6.16 × 10 ⁻⁷	6.40 × 10 ⁻⁷	—	—	150
	200	7.65 × 10 ⁻⁷	7.83 × 10 ⁻⁷	—	—	7.72 × 10 ⁻⁷	7.97 × 10 ⁻⁷	—	—	200
	250	9.22 × 10 ⁻⁷	9.39 × 10 ⁻⁷	—	—	9.29 × 10 ⁻⁷	9.54 × 10 ⁻⁷	—	—	250
	300	1.08 × 10 ⁻⁶	1.10 × 10 ⁻⁶	—	—	1.09 × 10 ⁻⁶	1.11 × 10 ⁻⁶	—	—	300
BG3305	150	1.64 × 10 ⁻⁶	—	1.56 × 10 ⁻⁶	1.64 × 10 ⁻⁶	1.71 × 10 ⁻⁶	—	1.60 × 10 ⁻⁶	1.71 × 10 ⁻⁶	150
	200	2.02 × 10 ⁻⁶	—	1.94 × 10 ⁻⁶	2.03 × 10 ⁻⁶	2.09 × 10 ⁻⁶	—	1.98 × 10 ⁻⁶	2.10 × 10 ⁻⁶	200
	300	2.79 × 10 ⁻⁶	2.99 × 10 ⁻⁶	2.71 × 10 ⁻⁶	2.79 × 10 ⁻⁶	2.86 × 10 ⁻⁶	3.13 × 10 ⁻⁶	2.75 × 10 ⁻⁶	2.86 × 10 ⁻⁶	300
	400	3.55 × 10 ⁻⁶	3.75 × 10 ⁻⁶	3.48 × 10 ⁻⁶	3.56 × 10 ⁻⁶	3.62 × 10 ⁻⁶	3.89 × 10 ⁻⁶	3.51 × 10 ⁻⁶	3.63 × 10 ⁻⁶	400
	500	4.32 × 10 ⁻⁶	4.52 × 10 ⁻⁶	4.24 × 10 ⁻⁶	4.32 × 10 ⁻⁶	4.39 × 10 ⁻⁶	4.66 × 10 ⁻⁶	4.28 × 10 ⁻⁶	4.39 × 10 ⁻⁶	500
	600	5.08 × 10 ⁻⁶	5.28 × 10 ⁻⁶	5.01 × 10 ⁻⁶	5.09 × 10 ⁻⁶	5.15 × 10 ⁻⁶	5.42 × 10 ⁻⁶	5.04 × 10 ⁻⁶	5.16 × 10 ⁻⁶	600
BG3310	150	2.19 × 10 ⁻⁶	—	1.88 × 10 ⁻⁶	2.21 × 10 ⁻⁶	2.47 × 10 ⁻⁶	—	2.02 × 10 ⁻⁶	2.49 × 10 ⁻⁶	150
	200	2.57 × 10 ⁻⁶	—	2.27 × 10 ⁻⁶	2.59 × 10 ⁻⁶	2.85 × 10 ⁻⁶	—	2.40 × 10 ⁻⁶	2.87 × 10 ⁻⁶	200
	300	3.34 × 10 ⁻⁶	4.14 × 10 ⁻⁶	3.03 × 10 ⁻⁶	3.36 × 10 ⁻⁶	3.61 × 10 ⁻⁶	4.69 × 10 ⁻⁶	3.17 × 10 ⁻⁶	3.64 × 10 ⁻⁶	300
	400	4.10 × 10 ⁻⁶	4.90 × 10 ⁻⁶	3.80 × 10 ⁻⁶	4.12 × 10 ⁻⁶	4.38 × 10 ⁻⁶	5.46 × 10 ⁻⁶	3.94 × 10 ⁻⁶	4.40 × 10 ⁻⁶	400
	500	4.87 × 10 ⁻⁶	5.67 × 10 ⁻⁶	4.56 × 10 ⁻⁶	4.89 × 10 ⁻⁶	5.15 × 10 ⁻⁶	6.22 × 10 ⁻⁶	4.70 × 10 ⁻⁶	5.17 × 10 ⁻⁶	500
	600	5.63 × 10 ⁻⁶	6.43 × 10 ⁻⁶	5.33 × 10 ⁻⁶	5.65 × 10 ⁻⁶	5.91 × 10 ⁻⁶	6.99 × 10 ⁻⁶	5.47 × 10 ⁻⁶	5.93 × 10 ⁻⁶	600
BG4610	340	1.79 × 10 ⁻⁵	2.02 × 10 ⁻⁵	1.69 × 10 ⁻⁵	1.82 × 10 ⁻⁵	1.87 × 10 ⁻⁵	2.17 × 10 ⁻⁵	1.74 × 10 ⁻⁵	1.92 × 10 ⁻⁵	340
	440	2.18 × 10 ⁻⁵	2.41 × 10 ⁻⁵	2.08 × 10 ⁻⁵	2.20 × 10 ⁻⁵	2.25 × 10 ⁻⁵	2.56 × 10 ⁻⁵	2.13 × 10 ⁻⁵	2.31 × 10 ⁻⁵	440
	540	2.57 × 10 ⁻⁵	2.79 × 10 ⁻⁵	2.46 × 10 ⁻⁵	2.59 × 10 ⁻⁵	2.64 × 10 ⁻⁵	2.95 × 10 ⁻⁵	2.52 × 10 ⁻⁵	2.69 × 10 ⁻⁵	540
	640	2.95 × 10 ⁻⁵	3.18 × 10 ⁻⁵	2.85 × 10 ⁻⁵	2.98 × 10 ⁻⁵	3.03 × 10 ⁻⁵	3.33 × 10 ⁻⁵	2.90 × 10 ⁻⁵	3.08 × 10 ⁻⁵	640
	740	3.34 × 10 ⁻⁵	3.57 × 10 ⁻⁵	3.24 × 10 ⁻⁵	3.37 × 10 ⁻⁵	3.42 × 10 ⁻⁵	3.72 × 10 ⁻⁵	3.29 × 10 ⁻⁵	3.47 × 10 ⁻⁵	740
	840	3.73 × 10 ⁻⁵	3.96 × 10 ⁻⁵	3.63 × 10 ⁻⁵	3.75 × 10 ⁻⁵	3.80 × 10 ⁻⁵	4.11 × 10 ⁻⁵	3.67 × 10 ⁻⁵	3.83 × 10 ⁻⁵	840
	940	4.12 × 10 ⁻⁵	4.35 × 10 ⁻⁵	4.02 × 10 ⁻⁵	4.14 × 10 ⁻⁵	4.19 × 10 ⁻⁵	4.50 × 10 ⁻⁵	4.06 × 10 ⁻⁵	4.22 × 10 ⁻⁵	940
BG4620	340	2.47 × 10 ⁻⁵	3.39 × 10 ⁻⁵	2.07 × 10 ⁻⁵	2.58 × 10 ⁻⁵	2.78 × 10 ⁻⁵	3.99 × 10 ⁻⁵	2.27 × 10 ⁻⁵	2.98 × 10 ⁻⁵	340
	440	2.86 × 10 ⁻⁵	3.77 × 10 ⁻⁵	2.46 × 10 ⁻⁵	2.96 × 10 ⁻⁵	3.17 × 10 ⁻⁵	4.38 × 10 ⁻⁵	2.66 × 10 ⁻⁵	3.37 × 10 ⁻⁵	440
	540	3.25 × 10 ⁻⁵	4.16 × 10 ⁻⁵	2.84 × 10 ⁻⁵	3.35 × 10 ⁻⁵	3.55 × 10 ⁻⁵	4.77 × 10 ⁻⁵	3.05 × 10 ⁻⁵	3.76 × 10 ⁻⁵	540
	640	3.64 × 10 ⁻⁵	4.55 × 10 ⁻⁵	3.23 × 10 ⁻⁵	3.74 × 10 ⁻⁵	3.94 × 10 ⁻⁵	5.16 × 10 ⁻⁵	3.44 × 10 ⁻⁵	4.14 × 10 ⁻⁵	640
	740	4.03 × 10 ⁻⁵	4.94 × 10 ⁻⁵	3.62 × 10 ⁻⁵	4.13 × 10 ⁻⁵	4.33 × 10 ⁻⁵	5.55 × 10 ⁻⁵	3.82 × 10 ⁻⁵	4.53 × 10 ⁻⁵	740
	840	4.41 × 10 ⁻⁵	5.34 × 10 ⁻⁵	4.02 × 10 ⁻⁵	4.51 × 10 ⁻⁵	4.71 × 10 ⁻⁵	5.93 × 10 ⁻⁵	4.17 × 10 ⁻⁵	4.82 × 10 ⁻⁵	840
	940	4.80 × 10 ⁻⁵	5.72 × 10 ⁻⁵	4.41 × 10 ⁻⁵	4.90 × 10 ⁻⁵	5.09 × 10 ⁻⁵	6.32 × 10 ⁻⁵	4.56 × 10 ⁻⁵	5.21 × 10 ⁻⁵	940
BG5520	980	1.46 × 10 ⁻⁴	1.64 × 10 ⁻⁴	—	—	1.52 × 10 ⁻⁴	1.76 × 10 ⁻⁴	—	—	980
	1,080	1.59 × 10 ⁻⁴	1.76 × 10 ⁻⁴	—	—	1.65 × 10 ⁻⁴	1.88 × 10 ⁻⁴	—	—	1,080
	1,180	1.71 × 10 ⁻⁴	1.88 × 10 ⁻⁴	—	—	1.77 × 10 ⁻⁴	2.00 × 10 ⁻⁴	—	—	1,180
	1,280	1.83 × 10 ⁻⁴	2.00 × 10 ⁻⁴	—	—	1.89 × 10 ⁻⁴	2.12 × 10 ⁻⁴	—	—	1,280
	1,380	1.95 × 10 ⁻⁴	2.13 × 10 ⁻⁴	—	—	2.01 × 10 ⁻⁴	2.25 × 10 ⁻⁴	—	—	1,380



RATED LIFE

To obtain the rated life of the BG type complete the following 2 equations and use the minimum value as your rated life.

Rated Life Equation for Guide Section

$$L_G = \left(\frac{f_c}{f_w} \cdot \frac{C}{P} \right)^3 \cdot 50$$

L_G : rated life (km) f_c : contact coefficient
 f_w : load coefficient C : basic dynamic load rating (N)
 P : working load (N)

Rated Life Equation for Ball Screw Section

$$L_a = \left(\frac{1}{f_w} \cdot \frac{C_a \text{ or } C_b}{P_a} \right)^3 \cdot 10^6$$

L_a : rated life (rev) C_a or C_b : basic dynamic load rating (N)
 f_w : load coefficient P_a : axis direction load (N)

$$L_a' = \left(\frac{1}{f_w} \cdot \frac{C_a \text{ or } C_b}{P_a} \right)^3 \cdot \ell$$

L_a' : rated life (km) C_a or C_b : basic dynamic load rating (N)
 f_w : load coefficient P_a : axis direction load (N)
 ℓ : ball screw lead (mm)

RIGIDITY

By utilizing four-point contact structure, the BG type provides extremely high rigidity. Figure I-11 shows deflection of each size of long block against radial load. Table I-12. shows the geometrical moment inertia of guide rails.

Figure I-11 Block Deflection against Radial Load

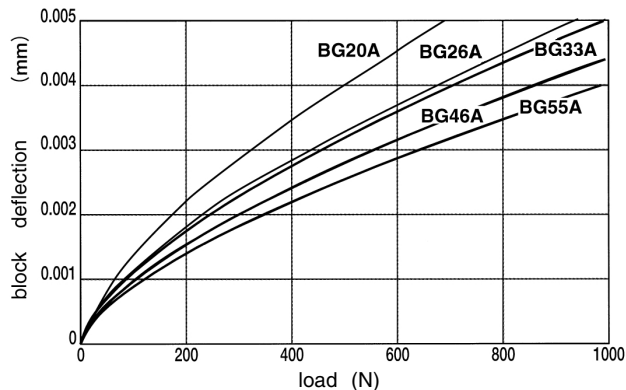

Table I-10 Contact Coefficient (f_c)

number of blocks used on an axis	contact coefficient (f_c)
1	1.0
2	0.81

Table I-11 Load Coefficient (f_w)

operating condition		load coefficient (f_w)
vibration/Shock	speed	
none	15m/min or less	1.0 ~ 1.5
small	60m/min or less	1.5 ~ 2.0
big	60m/min or more	2.0 ~ 3.5

Table I-12 Geometrical Moment Inertia of Guide Rails

part number	geometrical moment inertia (mm^4)		mass (kg/100mm)
	IX(X Axis)	IY(Y Axis)	
BG20	6.50×10^3	6.00×10^4	0.24
BG26	1.69×10^4	1.42×10^5	0.38
BG33	5.14×10^4	3.42×10^5	0.60
BG46	2.34×10^5	1.48×10^6	1.23
BG55	2.21×10^5	2.23×10^6	1.48

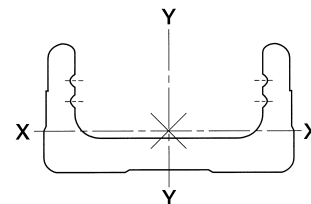

LUBRICATION AND OPERATING TEMPERATURE

- BG type contains a lithium-soap based grease. Apply similar grade of grease for the lubrication as required depending on your terms of operation.
- Use grease fitting to lubricate the guide block. For ball screw apply grease directly to surface of screw shaft.
- Unless otherwise instructed, a grease fitting is located as shown in Figure I-12.
- Resin parts are assembled in BG type. The recommended ambient working temperature is 80 °C or lower. Apply 55°C or lower for sensor option type.

Figure I-12 Location of Grease Fitting

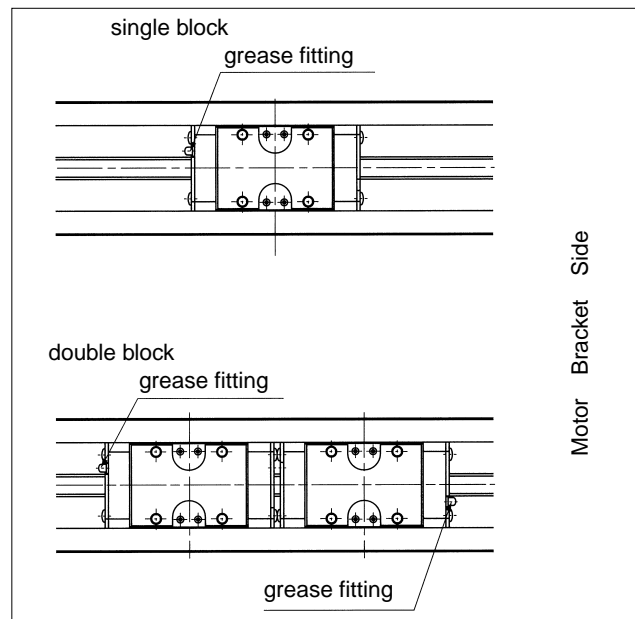

PRECAUTION FOR USE

- Handle as a precision component to avoid excessive vibration or shock. Rough handling will affect the smooth traveling and may reduce the precision performance and/or life of the BG type.
- DO NOT DISASSEMBLE. The accuracy of BG type is adjusted by the factory when it is assembled.
- Allow for extra stroke distance. If the guide block repeatedly collides with damper, it may cause damage.
- Depending upon the operating environment, dust and debris may contaminate BG type and disrupt the ideal ball circulation and operating performance.



BG20A,B –Without Top-Cover–

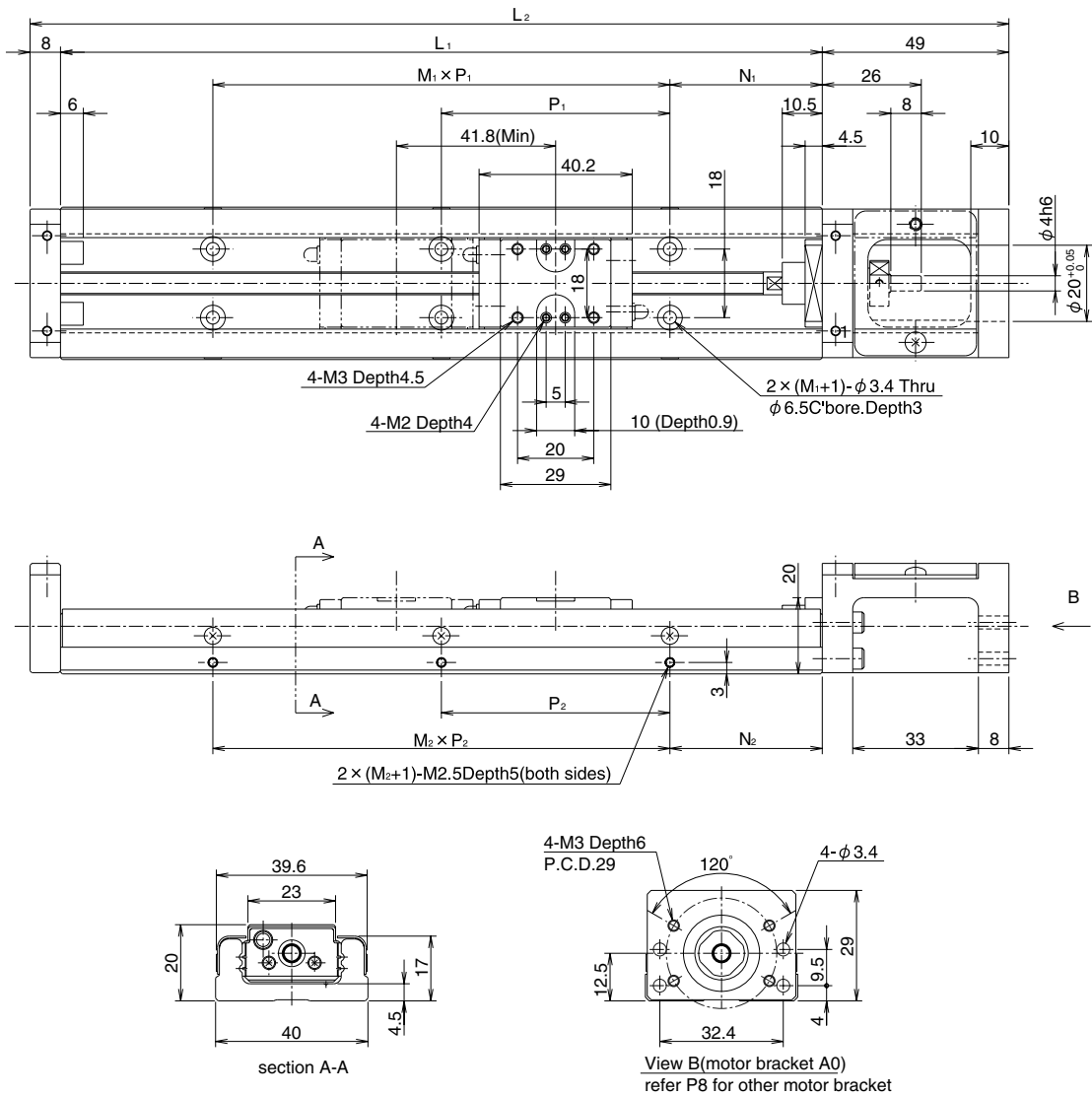

-With Top-Cover-

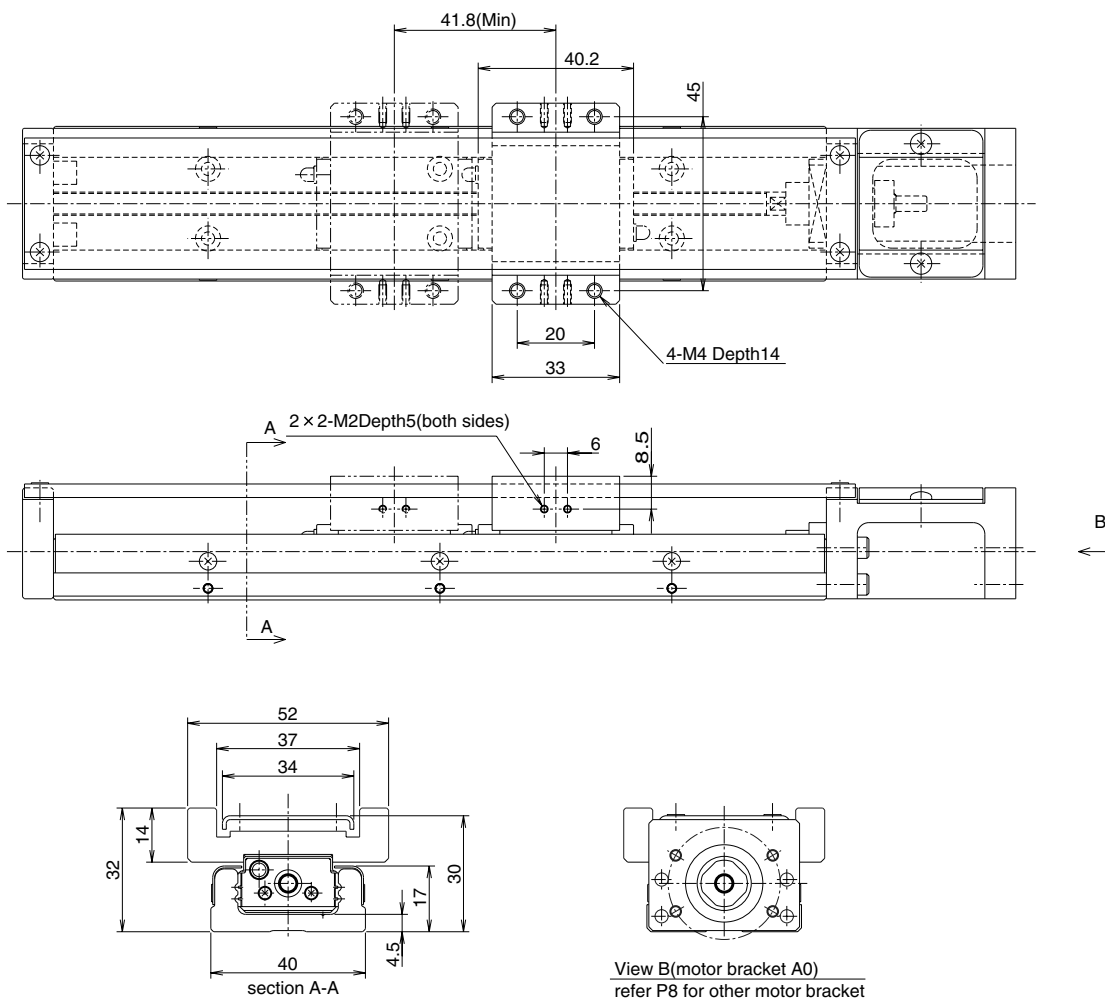

dimensions						stroke limit	
L ₁	L ₂	N ₁	M ₁ × P ₁	N ₂	M ₂ × P ₂	BG20A	BG20B
100	157	20	1 × 60	20	1 × 60	43	—
200	207	15	2 × 60	15	2 × 60	93	50
300	257	40		40		143	100

Stroke limit is traveling distance between both ends of the dampers.



BG26A,B -Without Top-Cover-

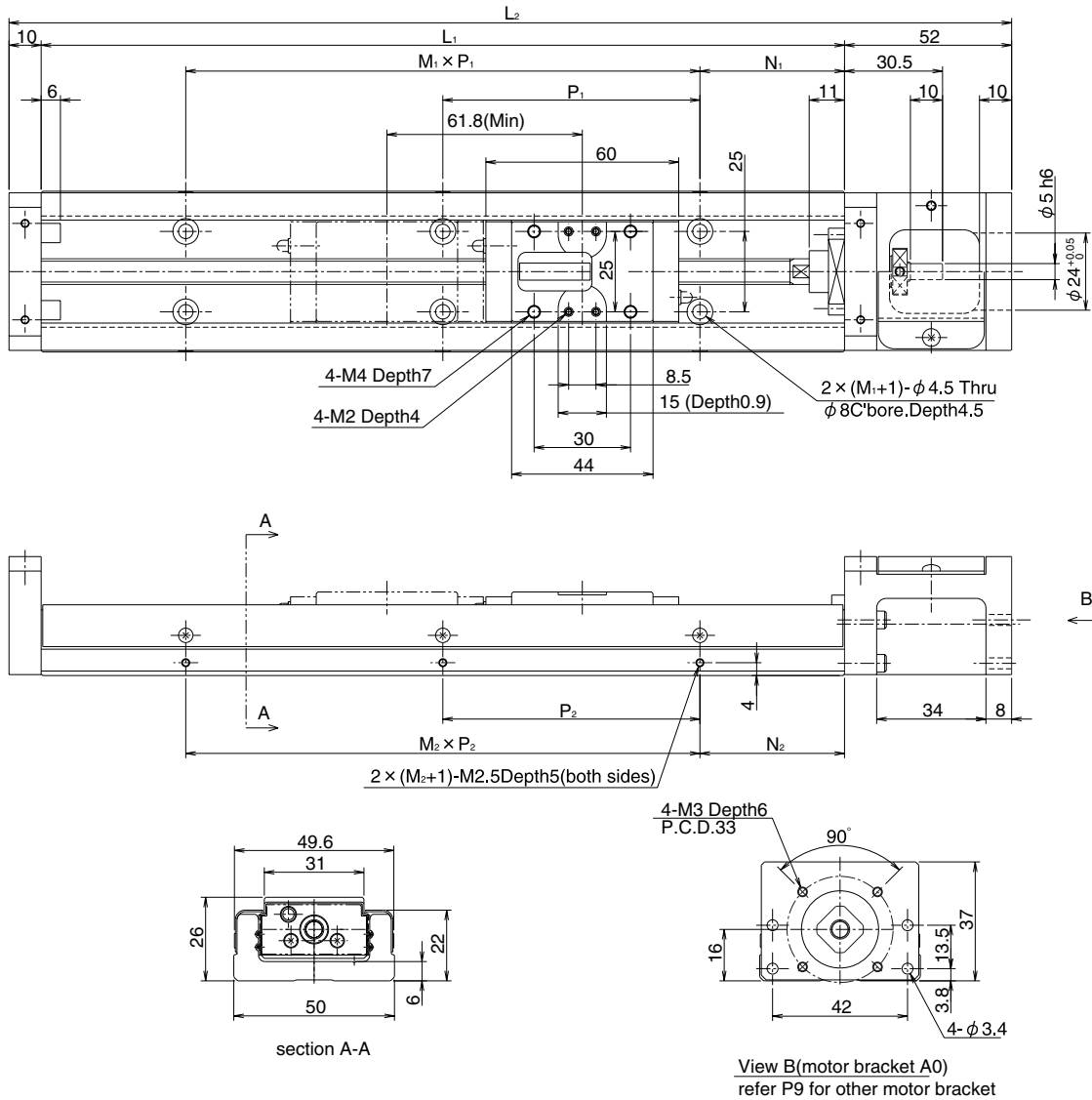

-With Top-Cover-

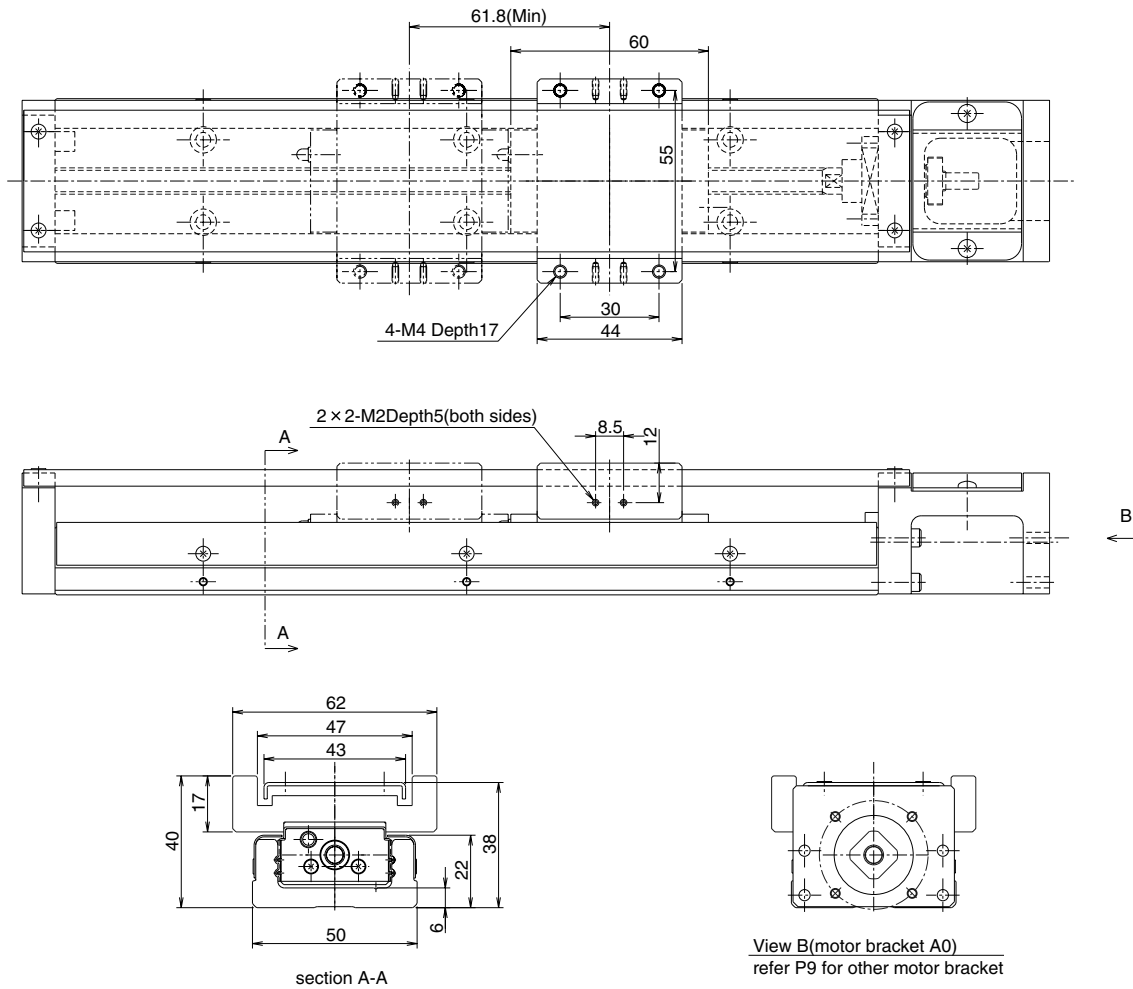

dimensions						stroke limit	
L ₁	L ₂	N ₁	M ₁ × P ₁	N ₂	M ₂ × P ₂	BG26A	BG26B
150	212	35	1 × 80	35	1 × 80	73	—
200	262	20	2 × 80	20	2 × 80	123	61
250	312	45		45		173	111
300	362	30	3 × 80	30	3 × 80	223	161

Stroke limit is traveling distance between both ends of the dampers.

- SLIDE GUIDE
- BALL SPLINE
ROTARY BALL SPLINE
- TOPBALL® PRODUCTS
- SLIDE BUSH
- SLIDE UNIT
- STROKE BUSH
SLIDE ROTARY BUSH
- SLIDE SHAFT
- SLIDE WAY
SLIDE TABLE
GONIO WAY
- ACTUATOR
- SLIDE SCREW



BG33A,B –Without Top-Cover–

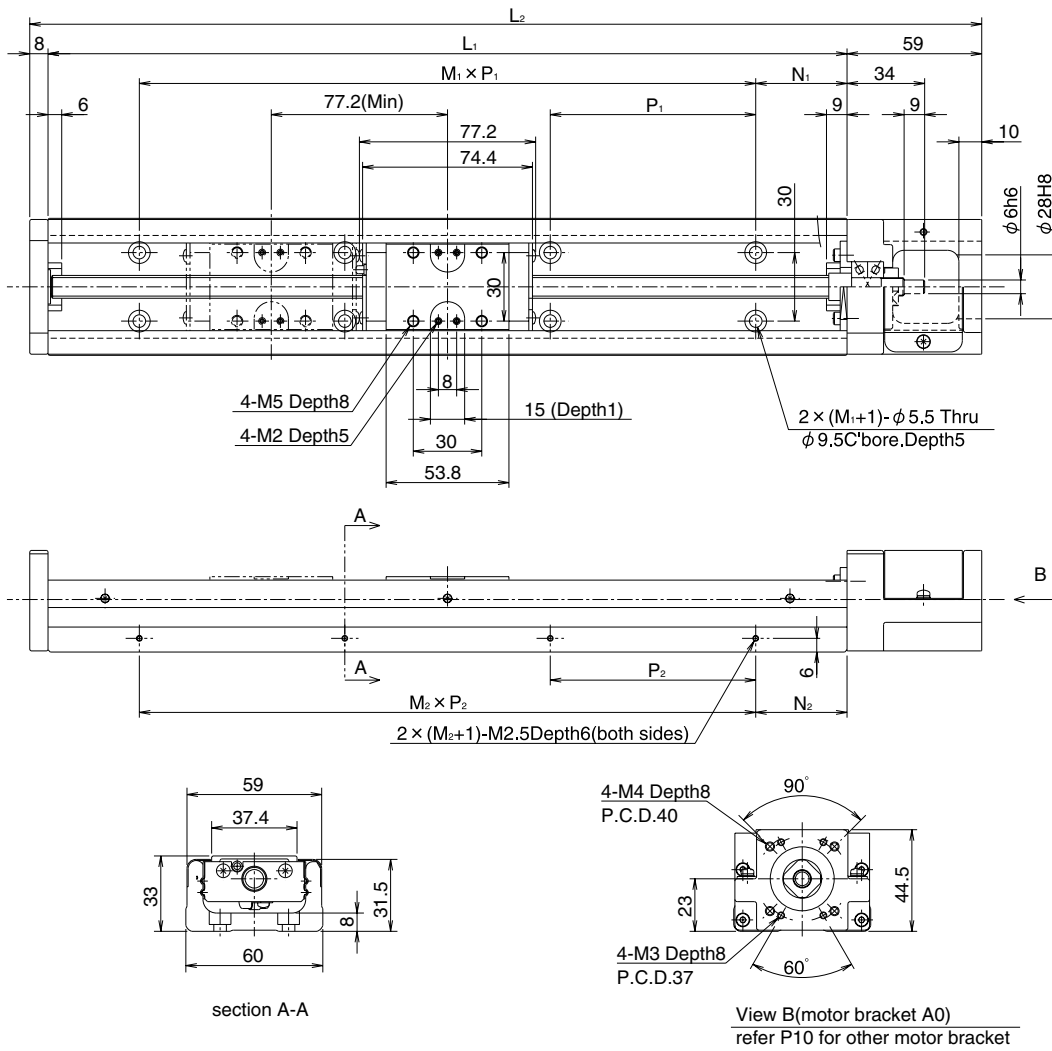

-With Top-Cover-

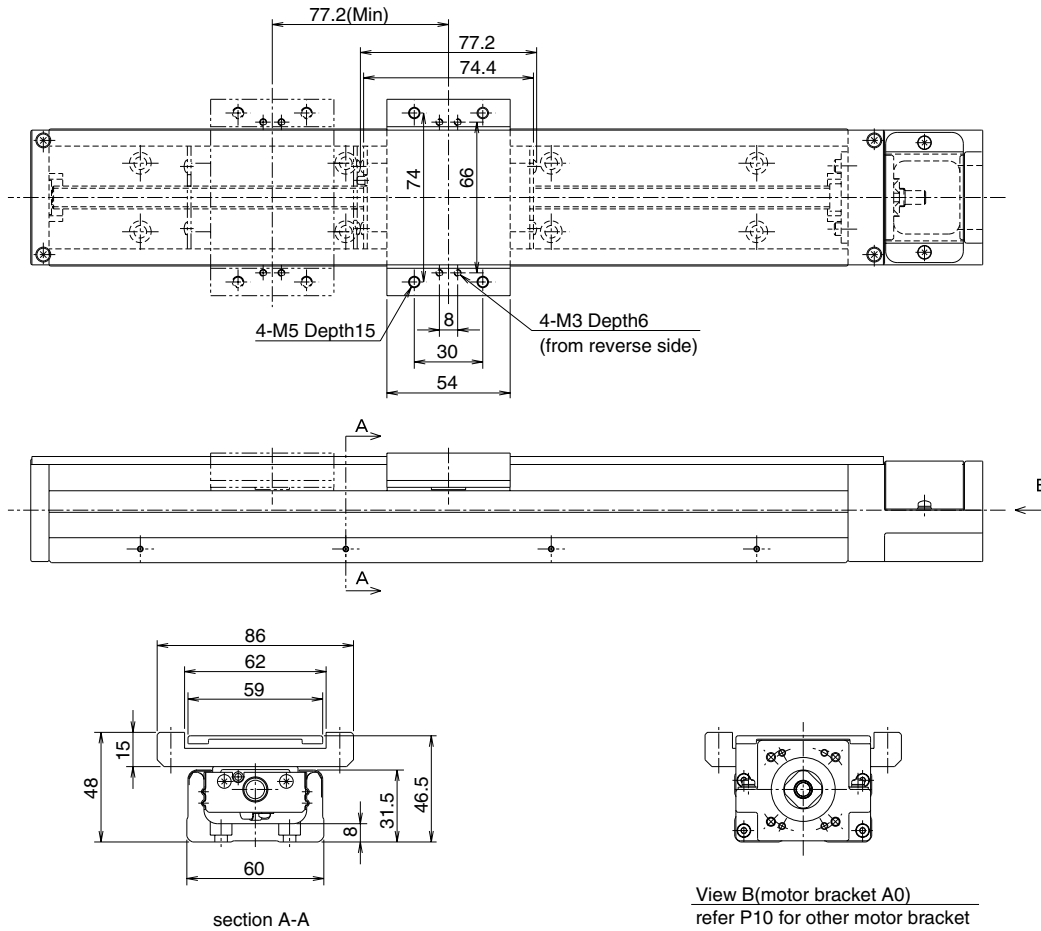

dimensions						stroke limit				
L ₁	L ₂	N ₁	M ₁ × P ₁	N ₂	M ₂ × P ₂	BG33A	BG33B			
150	217	25	1 × 100	25	1 × 100	60	—			
200	267					110	—			
300	367					210	133			
400	467					310	233			
500	567					410	333			
600	667	50	3 × 100	50	4 × 100	410	333			
						510	433			
						5 × 100	510	433		

Stroke limit is traveling distance between both ends of the dampers.



BG33C,D –Without Top-Cover–

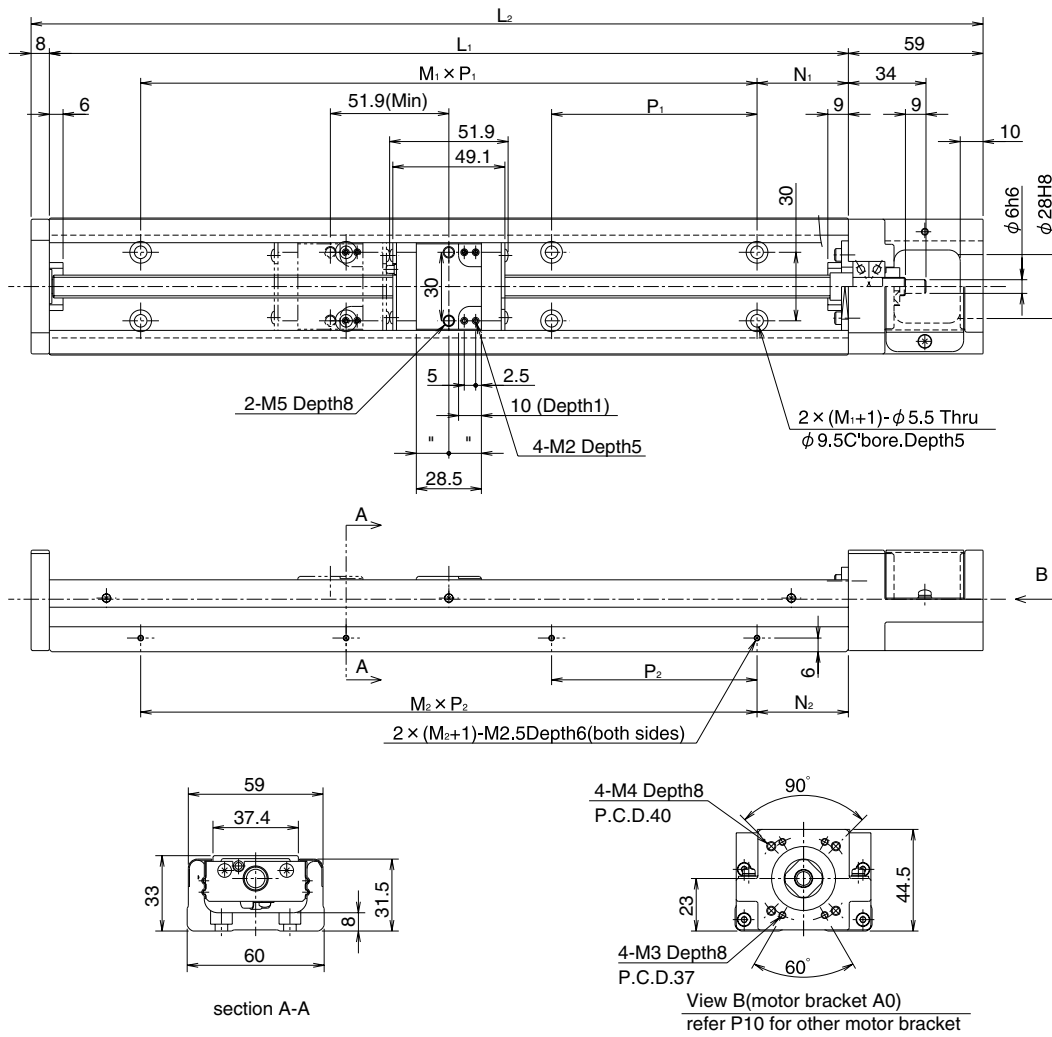

-With Top-Cover-

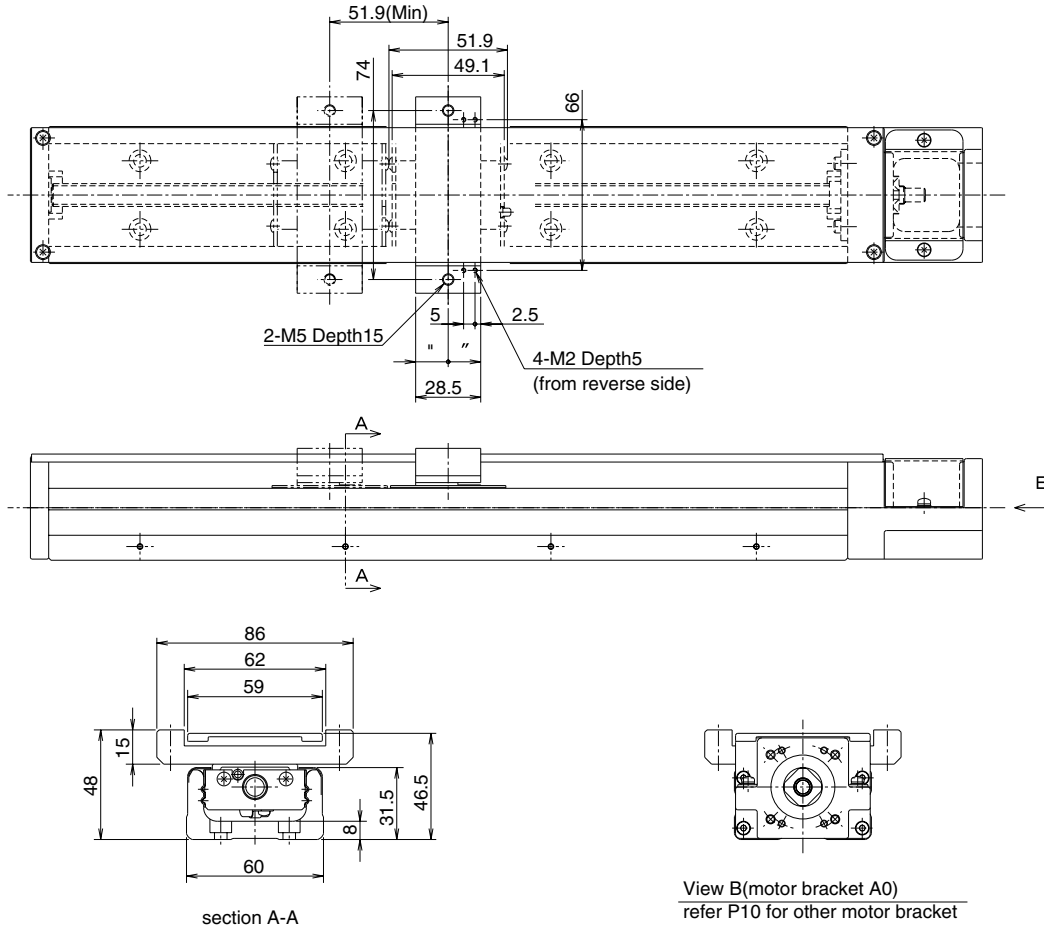

dimensions						stroke limit				
L ₁	L ₂	N ₁	M ₁ × P ₁	N ₂	M ₂ × P ₂	BG33C	BG33D			
150	217	25	1 × 100	25	1 × 100	85	34			
200	267					135	84			
300	367					235	184			
400	467					335	284			
500	567					435	384			
600	667	50	3 × 100	50	4 × 100	435	384			
						535	484			
						5 × 100				

Stroke limit is traveling distance between both ends of the dampers.



BG46A,B –Without Top-Cover–

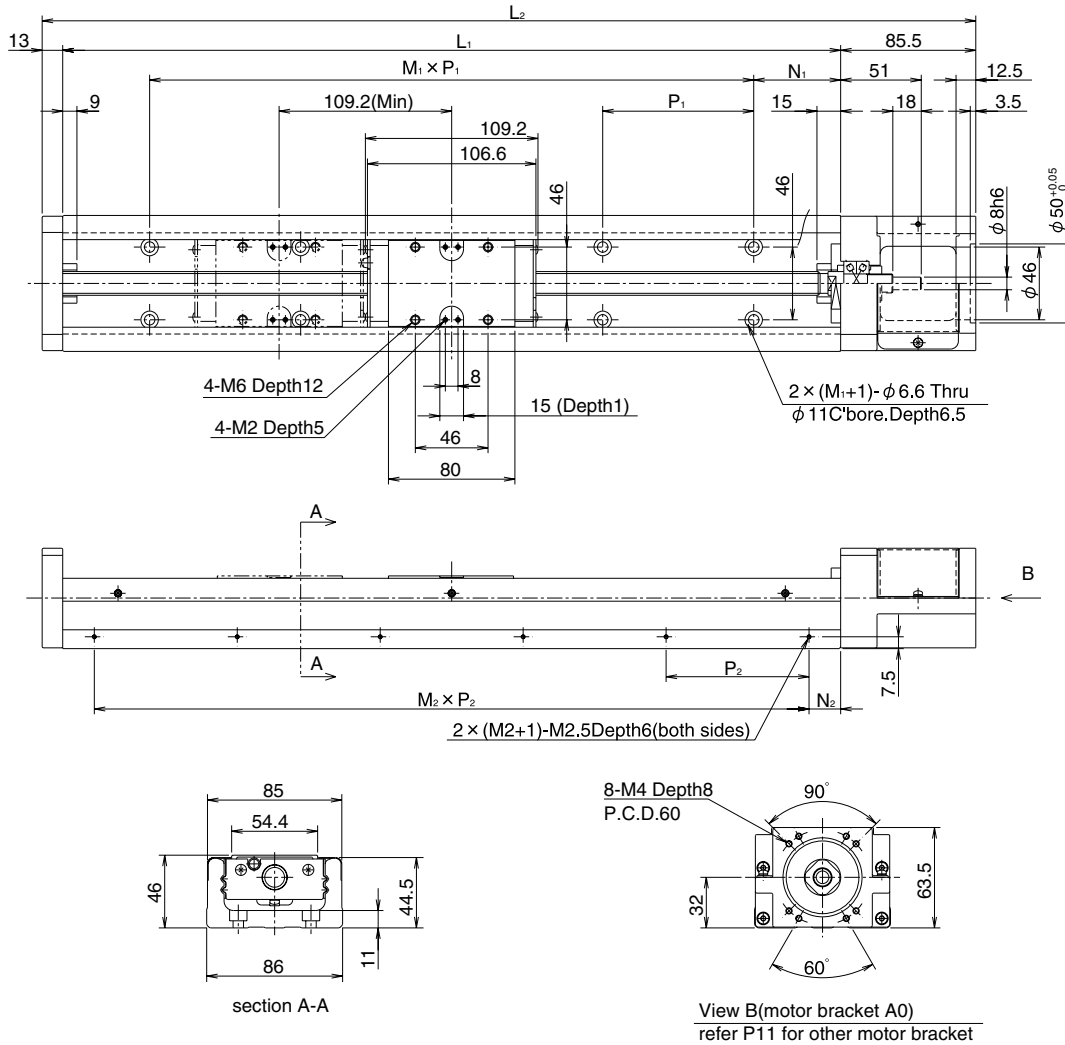

-With Top-Cover-

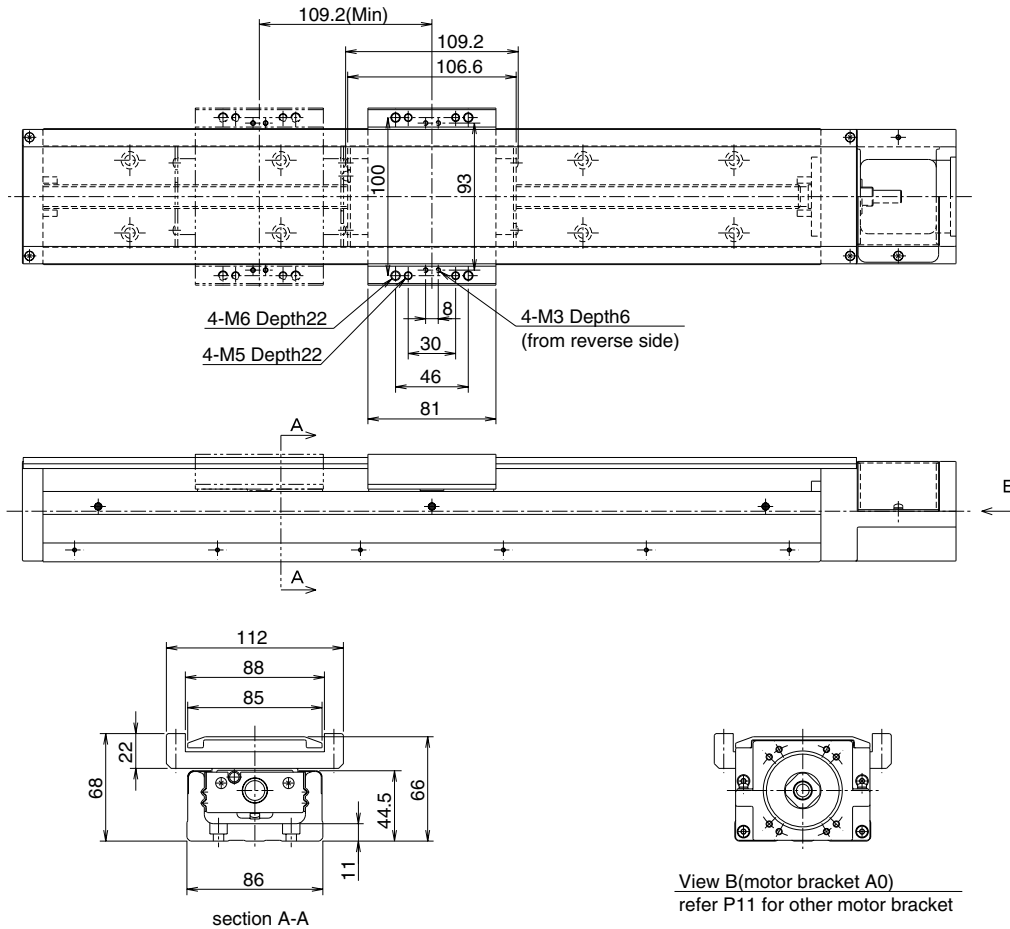

dimensions						stroke limit	
L ₁	L ₂	N ₁	M ₁ × P ₁	N ₂	M ₂ × P ₂	BG46A	BG46B
340	438.5	70	2 × 100	20	3 × 100	209	100
440	538.5		3 × 100		4 × 100	309	200
540	638.5		4 × 100		5 × 100	409	300
640	738.5		5 × 100		6 × 100	509	400
740	838.5		6 × 100		7 × 100	609	500
840	938.5		7 × 100		8 × 100	709	600
940	1038.5		8 × 100		9 × 100	809	700

Stroke limit is traveling distance between both ends of the dampers.

-With Top-Cover-

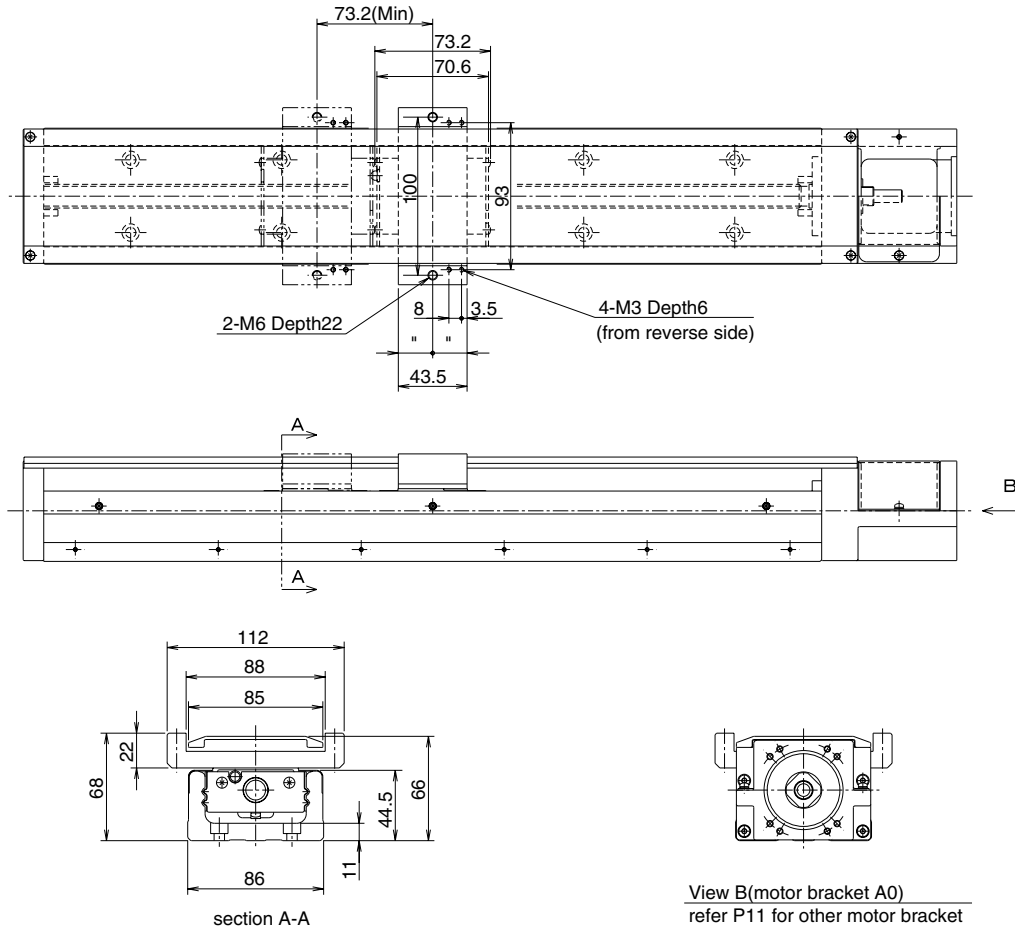

dimensions						stroke limit	
L ₁	L ₂	N ₁	M ₁ × P ₁	N ₂	M ₂ × P ₂	BG46C	BG46D
340	438.5	70	2 × 100	20	3 × 100	245	172
440	538.5		3 × 100		4 × 100	345	272
540	638.5		4 × 100		5 × 100	445	372
640	738.5		5 × 100		6 × 100	545	472
740	838.5		6 × 100		7 × 100	645	572
840	938.5		7 × 100		8 × 100	745	672
940	1038.5		8 × 100		9 × 100	845	772

Stroke limit is traveling distance between both ends of the dampers.

- SLIDE GUIDE
- BALL SPLINE
ROTORARY BALL SPLINE
- TOPBALL® PRODUCTS
- SLIDE BUSH
- SLIDE UNIT
- STROKE BUSH
SLIDE ROTARY BUSH
- SLIDE SHAFT
- SLIDE WAY
SLIDE TABLE
GONIO WAY
- ACTUATOR
- SLIDE SCREW



BG55A,B –Without Top-Cover–

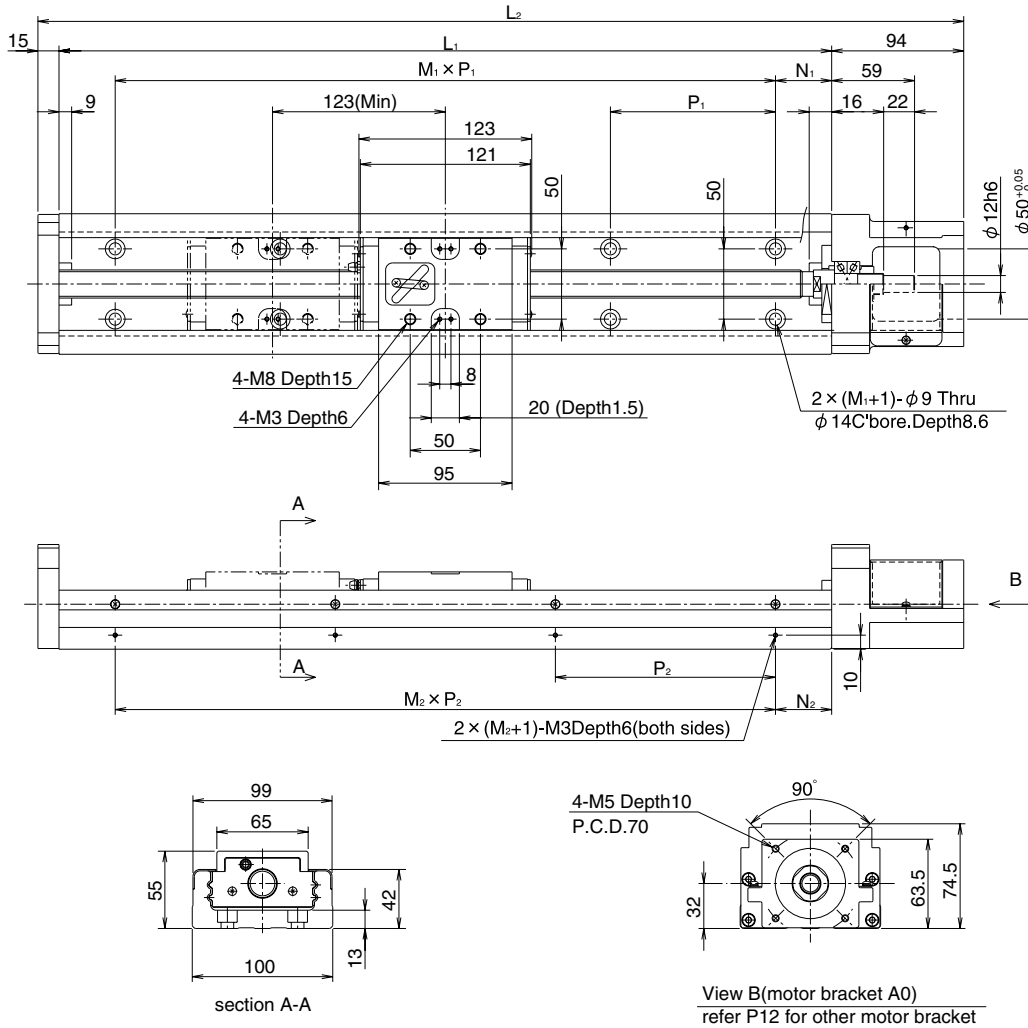

-With Top-Cover-

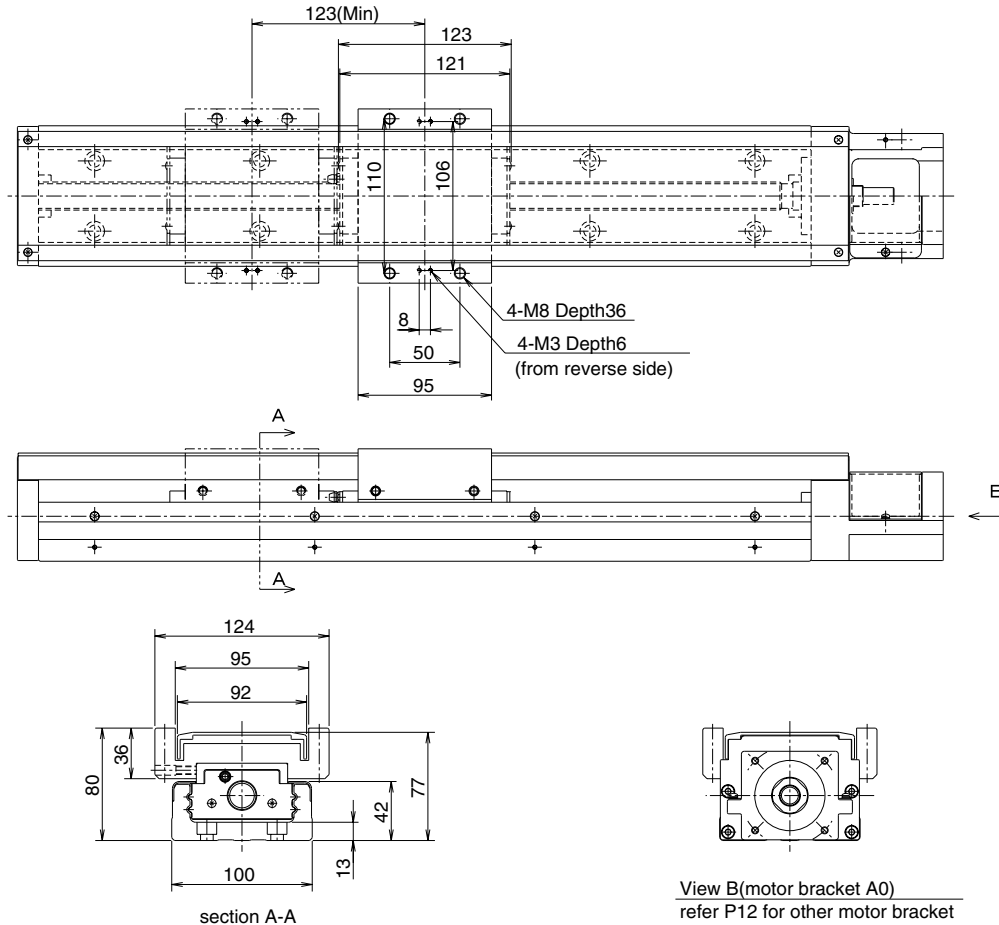

dimensions						stroke limit	
L ₁	L ₂	N ₁	M ₁ × P ₁	N ₂	M ₂ × P ₂	BG55A	BG55B
980	1089	40	6 × 150	90	4 × 200	834	711
1080	1189	15	7 × 150	40	5 × 200	934	811
1180	1289	65		90		1034	911
1280	1389	40	8 × 150	40	6 × 200	1134	1011
1380	1489	15	9 × 150	90		1234	1111

Stroke limit is traveling distance between both ends of the dampers.

- SLIDE GUIDE
- BALL SPLINE
ROTORARY BALL SPLINE
- TOPBALL® PRODUCTS
- SLIDE BUSH
- SLIDE UNIT
- STROKE BUSH
SLIDE ROTARY BUSH
- SLIDE SHAFT
- SLIDE WAY
SLIDE TABLE
GONIO WAY
- ACTUATOR
- SLIDE SCREW