



Reliability, availability, sustainability

Achieve your business goals with SKF downstream solutions



The Power of Knowledge Engineering

Every hydrocarbon processing plant is different.

Common challenges

The downstream hydrocarbon processing industry is going through dramatic changes on a global basis. North American refineries and chemical plants are reconfiguring to adapt to changing feedstock composition. The Middle East is investing dramatically in new capacity while Europe is reducing theirs. China, India and Brazil are making significant investments to align local production with their growing economies.

While each of these creates its own set of issues, they also have much in common. Chances are you are dealing with some or all of these challenges:

- **Workforce competency and skills development**
- **Retention or acquisition of critical knowledge**
- **Reduced staff size in some markets and ramping up in others**
- **Increased environmental and safety regulations**
- **Management demands to be more cost effective while still improving performance**
- **More rapid decision making in an era of increasing risk management**
- **Increasing influence of equipment reliability on slim operating margins**

Common goals

Regardless of type of process or plant architecture, most HPI facilities are focused on two primary goals regarding equipment health management:

- **Improving the reliability and availability of rotating equipment**
- **Implementing or optimizing an overall plant reliability and maintenance programme**



And the same.

An uncommon resource

For many companies around the world, the search for a partner that understands their business, their challenges and their machinery has led them to SKF. Through our global engineering, reliability and service organization, SKF provides a range of tools, technologies and value-added services unmatched by any other company.

SKF has a unique understanding of rotating equipment and how machine components and industrial processes are interrelated. This knowledge – coupled with our expertise in bearings, sealing solutions, lubrication systems, condition monitoring applications and reliability services – enables us to deliver effective, integrated solutions.

Working with both OEMs and plant maintenance professionals, SKF has provided assistance to improve designs of many types of equipment, ranging from pumps, fans and motors to gearboxes, compressors and turbines.

Combining fundamental machine knowledge with our deep understanding of maintenance and reliability processes adds up to what's most important to our customers: the real-world experience SKF brings to the table.



A proven work management process for



Asset Efficiency Optimization (AEO)

Experience has confirmed that when maintenance activities are conducted more strategically and effectively, value is created at all levels of an organization. By extending the life of critical assets, inventory and parts costs go down, resulting in significant savings. Depending on market conditions, these savings can combine with increased revenues resulting from greater machine availability and elimination of unanticipated downtime.

Through a proven methodology we call Asset Efficiency Optimization (AEO), SKF delivers solutions that can make your assets more productive, producing more without increasing capital spending on new equipment, and making the best use of your existing manpower resources.

In existing plants, the AEO process begins with identifying opportunities for improvement throughout your operation or enterprise. Our consultants work to understand your business goals, application challenges and plant culture to create a road map for improving reliability and profitability.

The Asset Efficiency Optimization process is based on our world-class best practices and provides a fully structured and documented maintenance programme.



Whether a new or existing operation, the AEO methodology combines a broad range of strategic and tactical tools to help you know:

- **What must you do?**
- **Why must you do it?**
- **Who must do it, when?**
- **How should it be done?**
- **What can you learn to keep improving?**

SKF will work with you to define areas of focus in order to get the fastest return on your investment. Your customized programme can include everything from training and logistics, to a full predictive maintenance service contract with qualified manpower and technology to help maintain your plant – even remotely.

optimizing performance

Existing plants

SKF provides a broad spectrum of services to meet the needs of existing plants. These range from a complete predictive maintenance (PDM) programme that includes everything from processes and procedures on asset management and work management to hardware and software to implement PDM, proactive reliability maintenance (PRM) and operator driven reliability (ODR) programmes.

New plants or processing units

Through a slightly modified version of the Asset Efficiency Optimization process, SKF can design and implement a complete maintenance programme for new assets to make them efficient and effective. This includes pre-populating the plant's computerized maintenance management system (CMMS) prior to onset of operations.

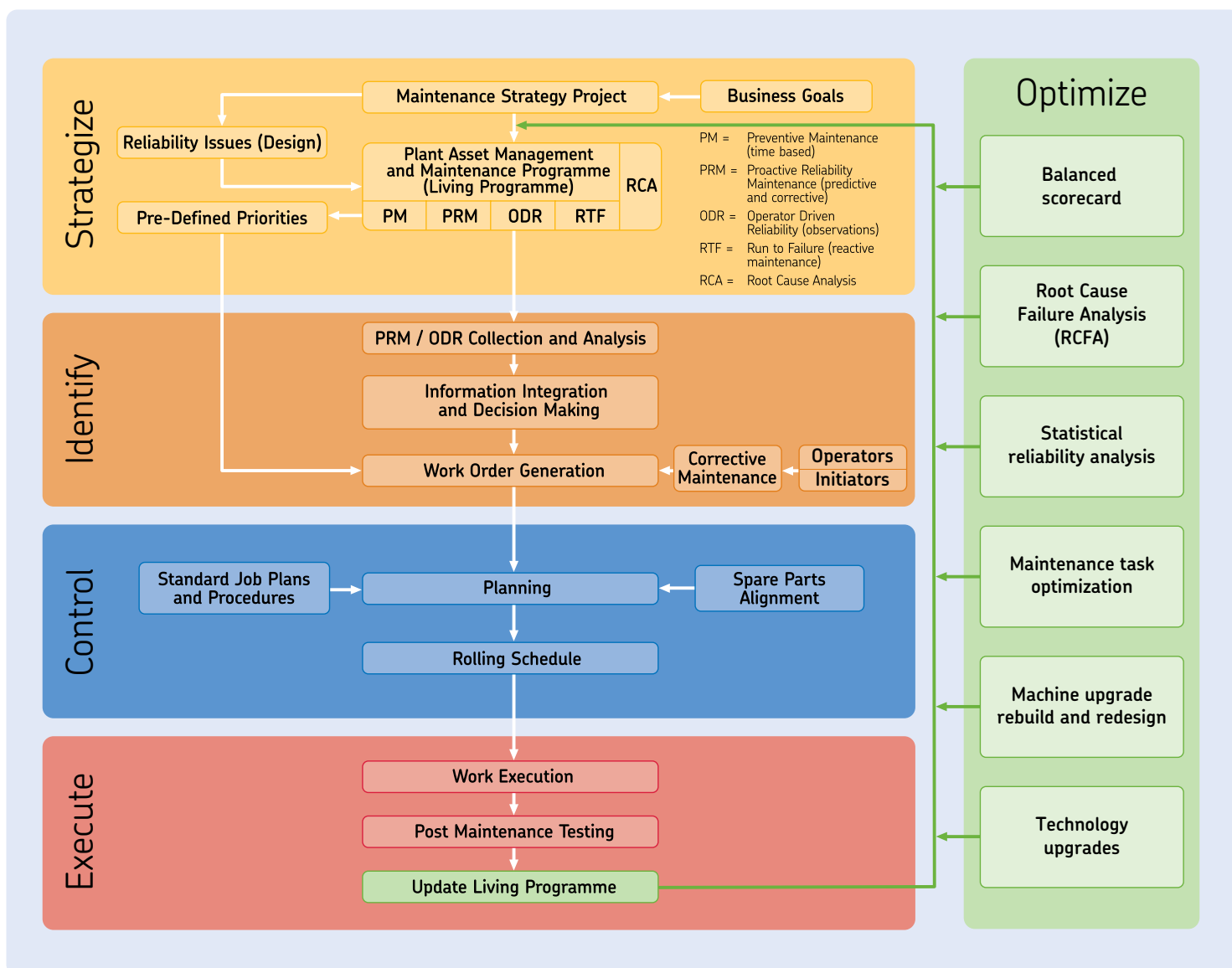

Assessing and benchmarking your asset

SKF asset management assessments

Asset Efficiency Optimization typically begins with an assessment that benchmarks your current programme against our best practices and other previously assessed plants.

Conducted by SKF with key members of your organization, the assessment provides a snapshot of your plant's maintenance and work management situation, taking into account industry-specific maintenance and reliability issues.

For existing plants, the 40-point SKF Client Needs Analysis (CNA) helps identify the top issues that need to be addressed and helps determine where opportunities for improvement exist as well as the potential cost benefit of these improvements. SKF can also assist with easy implementation.

For new plants, SKF consulting services lay the groundwork for success, identifying the processes, systems and programmes that are needed to help ensure the plant's efficiency from the first day of commercial operation.

For large companies with many sites, the SKF CNA process can be used to provide management with benchmarking insight and possible pathways to raise performance across the enterprise.

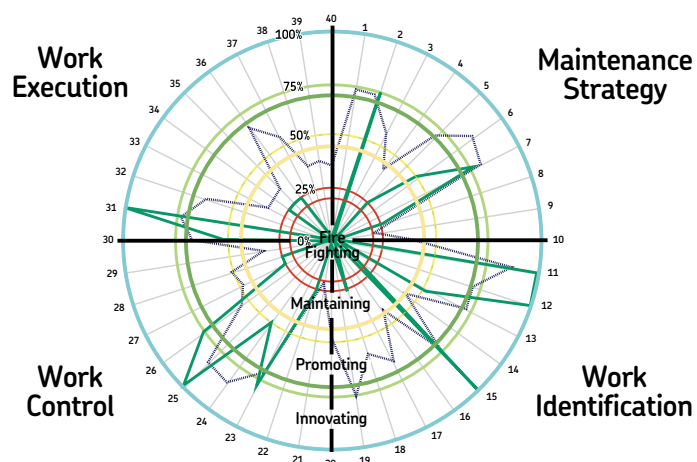

- Individual result
- Energy, power generation
- Fire Fighting
- Maintaining
- Promoting
- Innovating

SKF compares your current work management programme practices against our best practices and develops a spider chart that allows a quick understanding of this comparison against the 40 sub-areas assessed. The chart shows your score and defines it in terms of "fire-fighting, maintaining, promoting or innovating". The areas that have the greatest potential for improvement are highlighted as gaps.



management situation

Areas of focus

In each case, the ultimate goal of the assessment is to establish a continuous improvement programme based on industry experience and best practices.

Maintenance Strategy – A comprehensive maintenance strategy can transform maintenance from a cost centre into a profit centre.

Work Identification – Being able to better identify potential faults before they become a problem will decrease unplanned downtime and increase production efficiency.

Work Control – Detecting problems earlier enables better scheduling of labour and spare parts for repair. Machine uptime increases, while overtime, work backlog and total costs decrease.

Work Execution – With an optimum work execution programme, maintenance labour productivity increases, maintenance rework decreases and total maintenance costs are reduced.

Living Programme – Developing a living programme is essential to maintain and optimize the maintenance strategy and create a path to continuous improvement.

Action plans for implementation

Guided by the results of a 40-point analysis, SKF consultants can help you identify your plant's needs and improvement opportunities, and then develop appropriate action plans. SKF can implement and execute your plan, or train your team to do so – whatever is best for your organization and bottom line.

Importantly, we can also assist with cultural change management, providing system-wide support to facilitate the organizational changes needed to achieve sustainable efficiencies and cost savings.



Optimizing the machine life cycle to reduce total cost of ownership

SKF Life Cycle Management

As a supplier of components, systems and engineering expertise to manufacturers of all types of machinery, our view of the world is based on the Life Cycle Management (LCM) of an asset. Our solutions cover all aspects of the life cycle from improved designs with integrated solutions to enhanced operations and maintenance.

SKF can help improve performance and reduce Total Cost of Ownership through SKF Life Cycle Management, a proven approach to improving machine reliability and operational efficiency. The SKF service portfolio combines SKF competencies to address every stage of the machine life cycle, from 3-D modelling and simulation for equipment designers to cloud-based remote condition monitoring and training for industrial end users.

Whether you're an equipment design engineer or an end-user, SKF Life Cycle Management can help your organization:

- Optimize designs
- Reduce time to market
- Improve energy and resource efficiency
- Improve reliability
- Extend asset service life
- Improve productivity
- Minimize maintenance
- Reduce total cost of ownership

Depending on your needs, you can take advantage of these and other SKF offerings and capabilities.

- Maintenance programme assessments
- Maintenance strategy review
- Predictive and proactive maintenance strategy and execution
- CMMS/ERP implementation
- Asset diagnostic services
- Integrated hardware and software solutions
- A full range of mechanical services
- Engineering design and simulation
- Machine upgrades
- Remanufacturing services
- Expert training and technical support
- Asset management consulting services
- Lubrication and energy management services

Note: see case studies at the end of this brochure for examples.

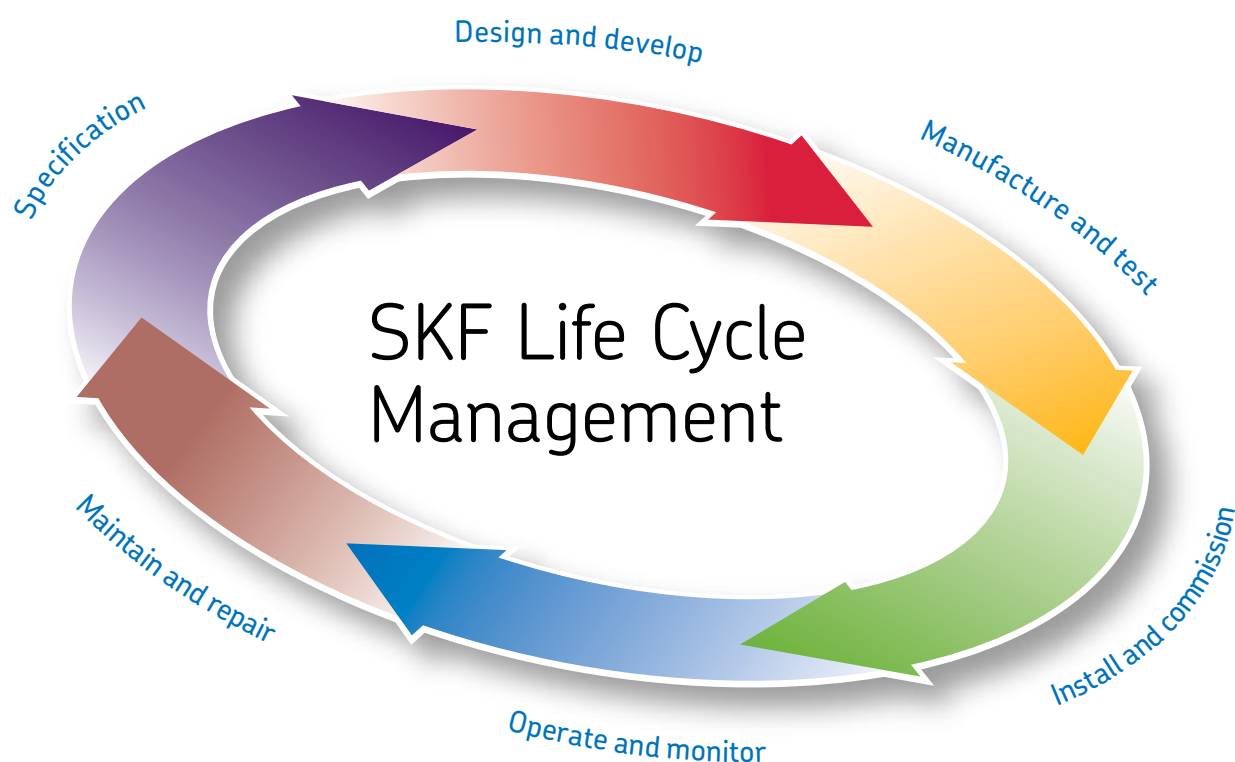

Applying SKF knowledge of rotating equipment to optimize reliability

Decades of machine and HPI industry experience

SKF has extensive knowledge and experience in solving reliability problems of numerous pieces of equipment in a refinery, chemical plant or along a pipeline. From pumps, motors and fans, to compressors and turbines, SKF has solved problems or lowered the total cost of ownership with solutions including specialized bearings, seals, lubrication, linear motion technologies and condition monitoring.

Some solutions begin with root cause analysis (RCA) to determine the true cause of a machine problem. Or, if the problem is known, SKF engineers go straight to it, and apply our application expertise to increase equipment reliability. With expertise in many areas that affect reliability, SKF is able to look at the problem from a systems perspective and provide an effective solution that can combine several SKF competency areas.

In some cases, SKF may have even partnered with the original equipment manufacturers of your plant machinery, providing us with knowledge that can be applied to your solutions.



OEMs, packagers and end users of compressor trains of all configurations rely on SKF for proven solutions that improve MTBF, reliability and uptime.



Cooling tower fans are applied throughout the downstream industry and pose specific maintenance challenges for which SKF has developed a broad range of solutions.

A wide range of expert services to support

SKF provides a broad spectrum of services to HPI and pipeline customers, including existing and new units prior to coming on line. These services range from on-line or on-site training in operator driven reliability to complete SKF management of predictive maintenance programmes.

In many cases, our involvement begins with one or two services and ultimately grows to include many, from data collection and remote monitoring, to lubrication management, motor testing and mechanical services including balancing and alignment.

You can select the services that best meet your needs and build upon that foundation as your requirements change.

Operator Driven Reliability (ODR)

SKF has proven processes and experience in setting up operator rounds, automating collected data, and training your staff to communicate findings and initiate timely corrective actions, making operations part of your asset reliability team.

Mechanical services

SKF can perform expert balancing, alignment, bearing installation and remanufacturing, and other critical services to optimize your machinery and your manpower resources.

Condition monitoring data collection and analysis

SKF provides on-site or remote condition monitoring services, supported by expert data analysis and internet-based communications capabilities. Programmes can include vibration monitoring, oil analysis, lubrication management and electric motor testing. Remote diagnostics is ideal for organizations with limited staff trained in predictive maintenance techniques or with sites located remotely from a central facility.

Predictive Maintenance

Predictive Maintenance programmes aim to detect machine conditions that will lead to failure and estimate the amount of time before that failure occurs.

Proactive Reliability Maintenance

An SKF Proactive Reliability Maintenance service contract applies best practice predictive maintenance activities and other processes to diagnose root causes of failures systematically. SKF then takes steps to help eliminate recurrences. The process includes using performance indicators and operational reviews to help you reach industry best-in-class benchmarks.

Contract Predictive Maintenance

There can be many challenges to implementing a new PdM programme or revitalizing an existing programme. These can include the lack of skilled resources for both data collection and data analysis, as well as the absence of the appropriate technology. One strategy adopted by many companies for fast implementation, and thus fast realization of the benefits of improved reliability, is contracting SKF to execute the programme, including supplying the latest technology for data collection. In this way, the business benefits are enjoyed while the existing staff is gradually acclimated to the new approach. SKF can continue to provide these services and technology going forward, or the customer can budget for the technology purchase and plan a gradual takeover of the programme.

In addition to these basics, an SKF Predictive Maintenance service contract also includes a determination for which proactive tasks can help extend machine life.

Maintenance Strategy Review

This process helps ensure that you are performing the right maintenance, on the right equipment, at the right time, with the right people, for the right reasons. Ultimate goals include reducing equipment damage and losses, increasing availability and reliability, and reducing overall maintenance costs. SKF can configure, support, interface to and help deploy a planned maintenance routine.

Root Cause Analysis

Root Cause Analysis (RCA) is a process that identifies the events responsible for machine failures and uses that information to help prevent future failures. After investigating three basic types of failure causes – physical or technical, human or organizational, procedural or decision making – SKF delivers a report on failure causes and effects, plus a comprehensive plan of corrective actions to prevent recurrence.



Training

your operational goals

Integrated equipment reliability

The responsibilities surrounding building a new facility or operating an existing facility can be challenging for the most experienced plant management. Success depends on achieving safety, reliability and availability goals – all with minimal staff, stringent budgets and tight time constraints. Key to achieving these goals is establishing an integrated equipment reliability programme where the core element is a robust, cost-effective maintenance programme.

Spares Optimization and Management

SKF Spares Optimization and Management can help plants reduce inventory costs and the risk of running out of stock. By providing a justifiable basis for carrying a given inventory, plus linking spare parts levels to asset criticality, SKF can help you reduce purchasing, supply and inventory costs while maintaining your optimum spare parts inventory.

Equipment redesign and continuous improvement

SKF applies SKF knowledge and services to design and deliver custom solutions to your toughest productivity challenges. SKF engineers can troubleshoot application issues and offer suggestions for machine upgrades that can extend service intervals and help eliminate recurring failures. Through the Asset Efficiency Optimization (AEO) process, improvement is a collaborative and ongoing process.



Mechanical services and service contracts

Predictive and proactive maintenance

Consultancy services

Improving machine reliability through inte

A complete suite of enabling technologies – hardware and software

Managing the mountain of data

For most plants, the problem is not a shortage of machine data. It's managing data efficiently and turning it into reliable, actionable intelligence.

A pioneer in the condition monitoring field since its inception, SKF has continued to lead the way with new products, systems and services that enable hydrocarbon companies and pipelines to use data to improve operational efficiency, plant safety and extend the asset's life cycle. These technologies have the required safety ratings to be used in hazardous areas.

Today, SKF provides a complete, integrated suite of enabling technologies, called the SKF @ptitude Monitoring Suite (@MS), to help you improve and maintain reliability while reducing maintenance costs. Data that can be presented in @MS includes both on-line and off-line vibration data, lube oil analysis data, process data and operator round data.



egrated condition monitoring

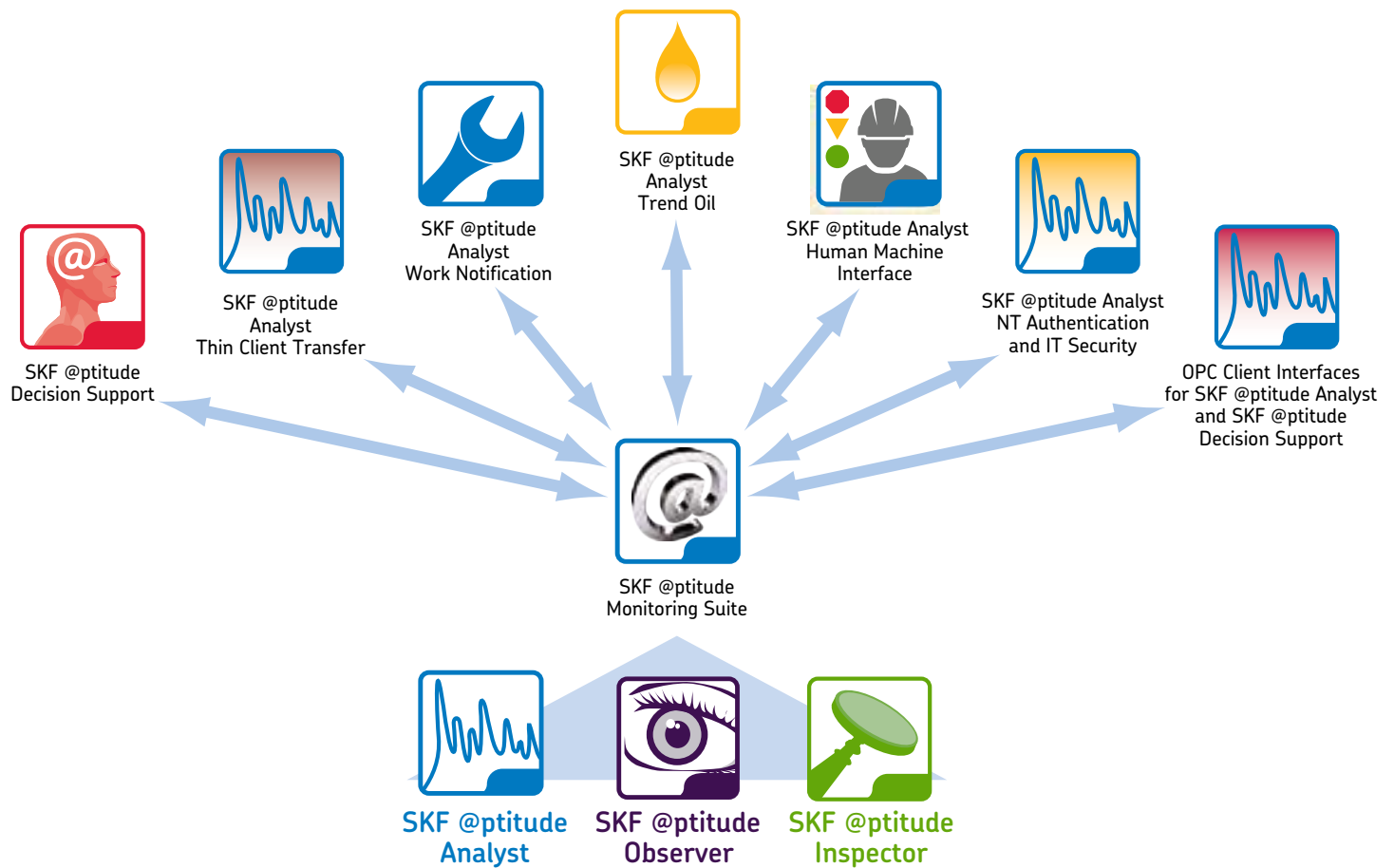

The SKF @ptitude Monitoring Suite

The SKF @ptitude Monitoring Suite forms the basis for a completely integrated approach to condition monitoring, permitting fast, efficient and reliable storage, manipulation and retrieval of large amounts of complex machine and plant information.

SKF @ptitude Monitoring Suite not only integrates vibration and operator rounds data but can also manage oil analysis results and process data with ties to CMMS, process data historians or process data access through OPC connections. Thus, data on a particular piece of equipment can be grouped together allowing quicker analysis to facilitate determination of asset health.

The SKF @ptitude Monitoring Suite includes three core software modules including SKF @ptitude Analyst, SKF @ptitude Observer (for operator driven reliability) and SKF @ptitude Inspector. Additional supporting applications and add-ons can be incorporated into the system to accommodate changing needs and to increase capabilities. One of these, SKF @ptitude Decision Support, accepts data from a wide range of sources to enable more effective and timely decision making across your entire facility or enterprise.

Building knowledge in fault detection

Reducing the mountain of data to actionable decisions

SKF @ptitude Decision Support (@DS) enables you to enhance the expertise of your team – a key advantage as your most experienced personnel retire, taking critical knowledge with them.

This dedicated decision support software links with a range of data sources, including ERP and EAM/CMMS, to facilitate accurate, timely, and consistent decision making and work order notification – within a single plant, across multiple facilities or miles of pipeline.

By fusing knowledge from diverse sources, the software provides information essential to effective machine and process analysis, diagnosis, reporting and corrective action.

@DS is based on logic models that can automatically analyze data from various sources and determine with high accuracy if a fault is present, as well as its severity. SKF already has over 100 models of HPI plant equipment that can be used right away with your equipment, eliminating the need to start from scratch.

SKF @ptitude Analyst and @ptitude Decision Support integrate your data to improve overall plant efficiency by replacing labour-intensive data analysis with an automated process that identifies the probability of specific faults within an asset or process, and then prescribes appropriate action.

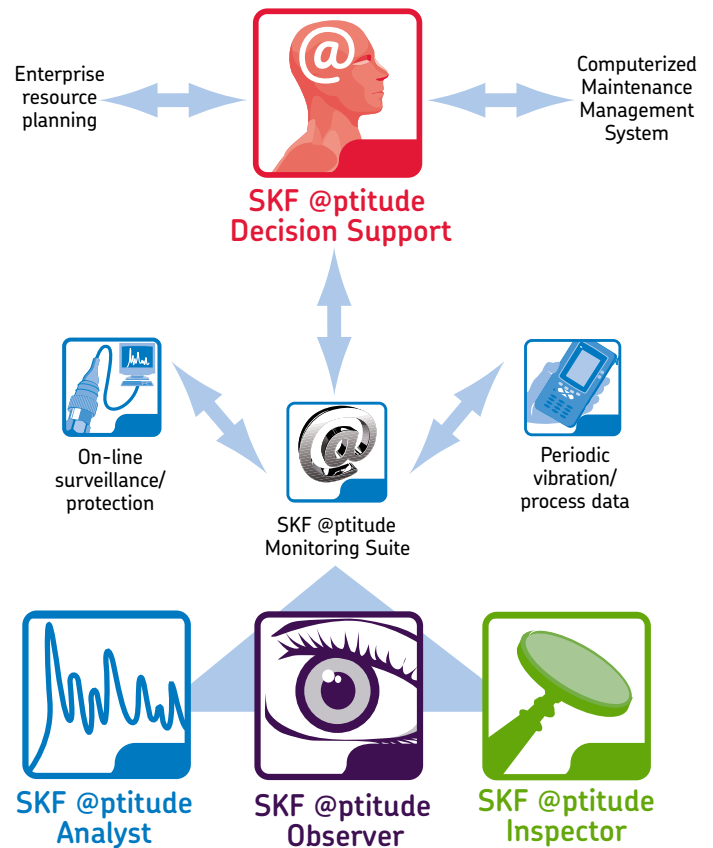

This smart filtering will allow your staff to focus on what needs attention versus data analysis.

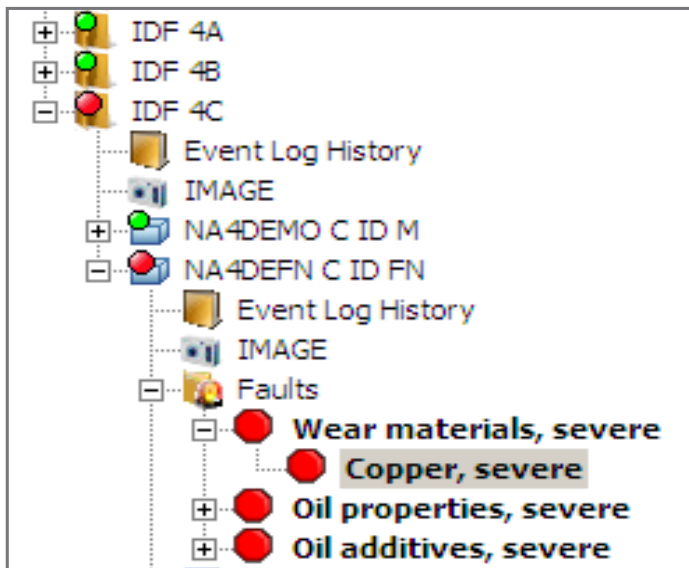

Using SKF @ptitude Decision Support provides the ability to quickly determine which asset is in fault and why. Fault detection is enhanced and can be acted on quickly while knowledge is concurrently captured on each fault. @DS replaces labour and time intensive analysis and saves time by automatically determining specific faults from a single or multi-parameter set of data including vibration, oil, operator inspections and process data.

Plantwide integration of machine data

Seamless integration of machine data

Designed to work seamlessly together and with your facility's CMMS, ERP or other plant-wide system, SKF hardware and software components make it easier to collect, analyze, use and share machine condition data. With one software platform that integrates data from a complete range of condition monitoring tools and data sources, the SKF @ptitude asset management system supports a plant- or enterprise-wide programme for optimized reliability, efficiency and safety.

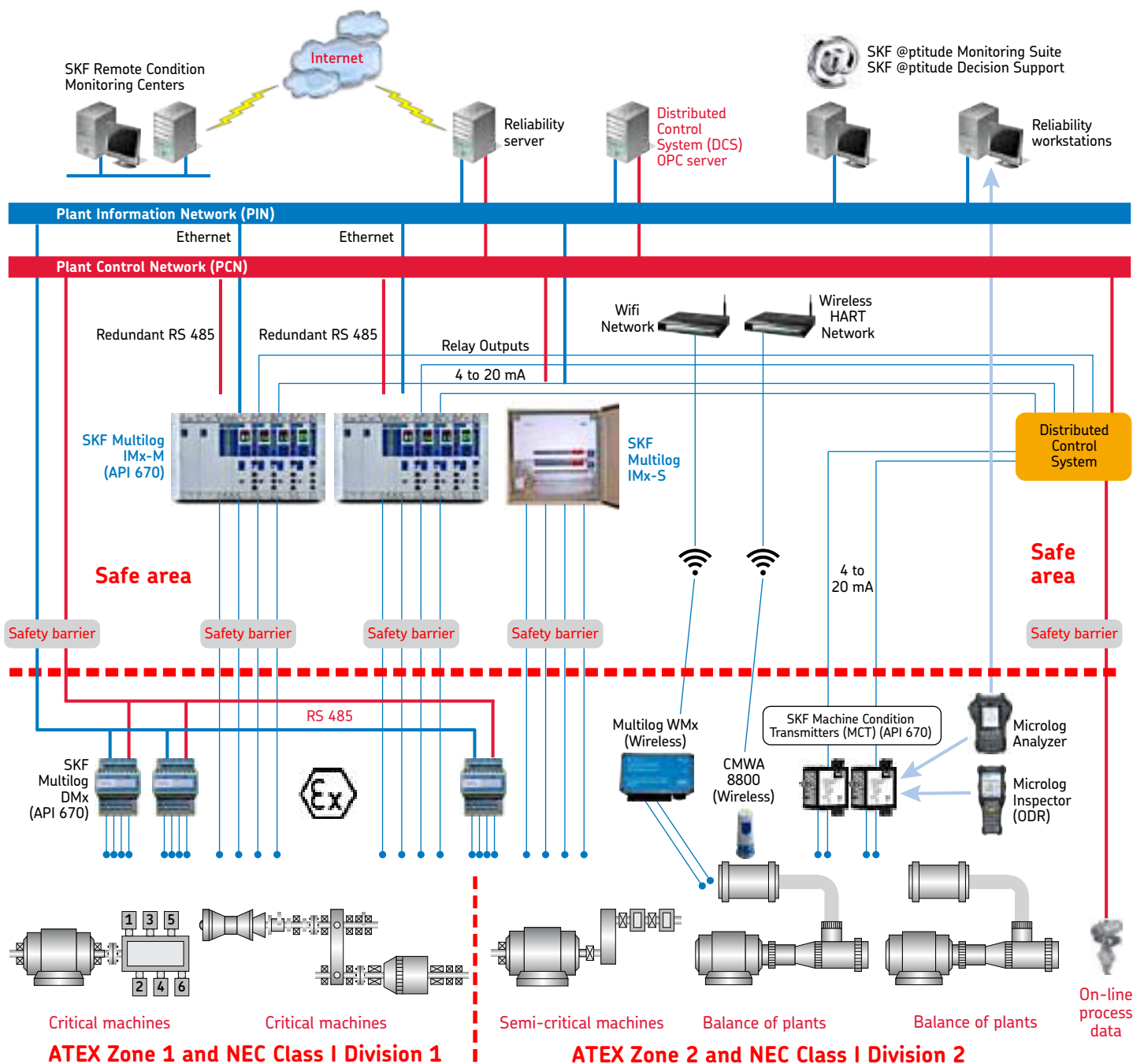

Portable and wireless collectors

Basic handheld tools

SKF handheld condition monitoring tools, available with safety ratings to allow use in hazardous areas, put the benefits of condition-based maintenance within reach for experts and novices alike. This basic equipment range allows users to spot-check critical machines and establish trends needed to identify problems early on, before they result in costly downtime.

Portable data collectors and analyzers

The SKF Microlog series of portable data collectors and analyzers can handle all tasks needed to perform predictive maintenance and on-the-spot analysis of rotating machinery. Units in the series are supported by SKF @ptitude software and meet requirements for use in HPI and pipeline hazardous areas.



Operator Driven Reliability (ODR) tools

Equipment operators are usually the first to detect even the smallest changes in machine conditions. The SKF Microlog Inspector series of ruggedized handheld mobile computers, safety-rated for hazardous environments, allows operators to communicate findings and initiate timely corrective actions. These SKF tools also facilitate communication between departments, making it easier to implement and run an ODR programme.



SKF Wireless Machine Condition Sensor

A cost-effective alternative to hard-wired monitoring solutions, the SKF Wireless Machine Condition Sensor combines a sensor, data collector and radio into one compact, battery-operated unit. Ideal for hazardous and hard-to-access locations, the system collects overall machine vibration, FFT spectrum and temperature data and uses the WirelessHART protocol, forming a mesh network that provides access to locations where traditional WiFi will not reach.

SKF Machine Condition Indicator



The standalone SKF Machine Condition Indicator (MCI) gives plants a reliable, affordable way to monitor non-critical machinery. A vibration sensor and an alarm indicator in

one unit, the fully sealed, battery-powered MCI requires no wired or wireless connections, installing directly on machinery for permanent, periodic vibration and temperature monitoring. A series of LEDs on top of the unit alerts operators and maintenance technicians to developing issues that may require the machine to undergo a further analysis.

On-line surveillance and protection

Machine condition transmitters from SKF

SKF offers a complete line of machine condition transmitters, engineered to deliver added value to essential production equipment. They provide vital information on machine and bearing performance that helps maximize potential machine utilization. Each standalone monitoring device is connected to a permanently mounted sensor on a machine. The devices provide low-cost

continuous monitoring of specific machine, gear and bearing performance parameters in pumps, fans, motors and other general purpose machinery.



SKF Multilog On-line System WMx

Offering the functionality of a portable data collector/analyzer, the wireless SKF Multilog WMx is much more cost-effective to install and implement than a traditional on-line system. Compact and field-mounted, the system enables remote, wireless monitoring of essential machinery, with less project engineering and documentation.



SKF Multilog On-line System DMx

Providing condition monitoring and machine protection in a very small footprint, the intrinsically safe SKF Multilog DMx eliminates the need for bulky cabinets.

Four-channel vibration monitoring and on-board proximity probe drivers allow processing requirements, from transducer to dynamic data, to be performed safely on the machine skid.



SKF Multilog On-line System IMx-S

The SKF Multilog On-line System IMx-S is a powerful, cost-effective solution for a variety of condition monitoring applications. With highly configurable inputs and local LAN or internet compatibility, the IMx-S provides a complete array of analysis capabilities to suit most monitoring strategies for semi-critical and essential machines.



SKF Multilog On-line System IMx-M

The SKF Multilog On-line System IMx-M is a classic, rack-based system that is a powerful and flexible solution for a variety of condition monitoring and machine protection applications. Together with SKF @ptitude Monitoring Suite software, the SKF Multilog IMx-M provides a complete system for critical machinery shutdown/trip and early fault detection and diagnosis.



Specialized bearings

With over 100 years as a global leader in bearings, the SKF standard product range is the broadest in the industry – covering all rotating machines that use rolling element bearings in a typical refinery or chemical plant. When the standard range will not suffice, SKF responds to new challenges with innovation. Here are a few examples:

Insocoat Bearings for Motors

Electric current passing through a bearing causes arcing and microwelding across the rolling element and raceway, leading to early and often catastrophic failure. Correcting the ground loop that is the root cause of this phenomenon is often a vexing problem to solve.

SKF has developed the Insocoat bearing to prevent passage of electric current through the bearing. It utilizes a plasma coating that physically transforms the bearing steel into an insulating layer. Applied to the outer or inner ring diameter, the basic bearing dimensions are the same as a standard bearing, thus permitting an easy field retrofit / upgrade.



PumPac Angular Contact Bearings for Centrifugal Pumps

Process pumps throughout a downstream plant can subject their bearings to excessive or varying thrust loads beyond original design specifications. Often the original equipment bearings are not able to cope with these higher loads, resulting in reduced MTBF (Mean Time Between Failure), higher repair cost and even operational losses.

SKF developed the PumPac Angular Contact Bearing range to deal with these challenges.



SKF ConCentra bearing units: Engineered for high reliability in harsh conditions

SKF ConCentra ball and roller bearings can handle punishing outdoor conditions as well as heavy loads, shock loads and contaminants. They offer a proven, cost-effective alternative to conventional bearing and housing arrangements.



SKF ConCentra bearing units perform well wherever maintenance requirements are tough and minimal. Greased and sealed, ready and easy to mount, the units help cut maintenance demands.

Sour gas bearings

The SKF sour gas solution is a robust rolling bearing arrangement consisting of high-nitrogen, stainless steel rings, ceramic rolling elements and polymeric PEEK cages. Currently installed in several highly demanding refinery, gas well boosting and recip boosting operations, the SKF sour gas solution is helping these operations increase run length from months to several years. The result? A sharp reduction in maintenance demands and operational costs, and an enabler for new low cost compressor setups.



Hybrid bearings

Hybrid bearings have rings made of bearing steel and rolling elements made of bearing grade silicon nitride (Si_3N_4). Because silicon nitride is such an excellent electrical insulator, hybrid bearings can be used to effectively insulate the housing from the shaft in both AC and DC motors as well as in generators.

In addition to being an excellent insulator, hybrid bearings have higher speed capabilities and provide longer bearing service life than standard bearings under the same operating conditions. Hybrid bearings also perform extremely well under vibrating or oscillating conditions.



Customized sealing solutions

Improving application performance with sealing solutions from SKF

Seals are critical system components that help promote system performance, reliability and efficiency of the complete machinery. The implications of a non-performing sealing solution in terms of consequential damage to the machinery and lost production can be significant. SKF is a leader in high-quality, custom-engineered sealing solutions offering a comprehensive range of both moulded and machined seals. Our flexible production system reduces manufacturing and dispatch time to a minimum for virtually any dimension and design. This includes large diameter sizes up to 4 000 mm and proprietary material formulations for problem applications.

SKF will help you identify the right sealing solution for your application. SKF solutions includes a wide range of designs, sizes and high-performance rubber and polyurethane materials to:

- Withstand high or low operating temperatures
- Resist chemicals as required
- Reduce relubrication and cleaning costs
- Minimize risk of leakage and environmental impact



Radial shaft seals



Machined seals

Using a special welding technique, SKF can manufacture seals in different polymeric materials up to 4 000 mm in diameter as one piece and larger with very short delivery times. We offer virtually unlimited seal designs and an extensive range of sealing materials (including materials certified to or complying with a broad range of industry standards and regulation).



Problem-solving seals for the chemical processing industry

The chemical processing industry utilizes high temperature processes and requires exposure of equipment to harsh chemicals. This demanding environment can be extremely damaging to seals, resulting in costly maintenance and repairs.

SKF has developed elastomeric materials to handle the high temperatures and aggressive chemicals used in the industry. These materials can be produced into a wide range of seal profiles and sizes, and using our industry-leading SKF Seal Jet Machining process, we can provide very quick response times for custom requirements.



Magnetic bearing systems

Active magnetic bearing capabilities overview

The first compressor equipped with an SKF S2M Magnetic Bearing, commissioned in 1985, is still running. Since then, we have partnered with many of the world's leading OEMs and operators to harness the power of magnetic levitation to address the need for high speed and high reliability active magnetic bearings in the most demanding operating environments.

SKF experience includes more than 1 000 installations in the oil and gas industry, including upstream, midstream and downstream processes. SKF is now pioneering the use of magnetic bearings for the first natural gas centrifugal compressors placed on the seabed at the Åsgard field in the Norwegian Sea.

For downstream processes, SKF S2M Magnetic Bearings have been chosen for gas compressors, polyethylene compressors, high-speed electric motor drives, ethylene turboexpanders, power generation turbogenerators, high speed blowers and others.

When customers need to increase the reliability and availability of their process machines, SKF has documented cases where 99–100% reliability is the standard. Many users have reported more than 100 000 hours – without any fault related to magnetic bearings. Typically, MTBF (Mean Time Between Failures) is more than 40 000 hours.

Advantages over oil lubricated bearings

Using oil lubricated bearings in cryogenic turboexpanders can be problematic with operating temperatures as low as $-150\text{ }^{\circ}\text{C}$ ($-238\text{ }^{\circ}\text{F}$). Should bearing seals fail, oil will enter the process, freeze and begin to solidify, at which point the process must be shut down and the equipment laboriously cleaned.

SKF S2M Magnetic Bearings eliminate the possibility of oil freezing and reduce the risk of oil spills, contamination and leakage because they operate without lubrication. SKF S2M Magnetic Bearings have operated in applications as low as $-250\text{ }^{\circ}\text{C}$ ($-418\text{ }^{\circ}\text{F}$) and are ideally suited for small frame turboexpanders used for gas processing applications.

SKF S2M Magnetic Bearings can also operate directly in a natural gas environment, so there is no need for shaft seals, thereby eliminating seal wear, maintenance, replacement and downtime issues. Shaft length can also be reduced, which improves shaft stiffness and rotor dynamic stability.

And, when elimination of lubrication system, gearbox, couplings and drive motor are considered, SKF S2M Magnetic Bearings dramatically reduce the footprint and tonnage requirements. In addition, process availability, equipment reliability and OPEX are significantly improved.

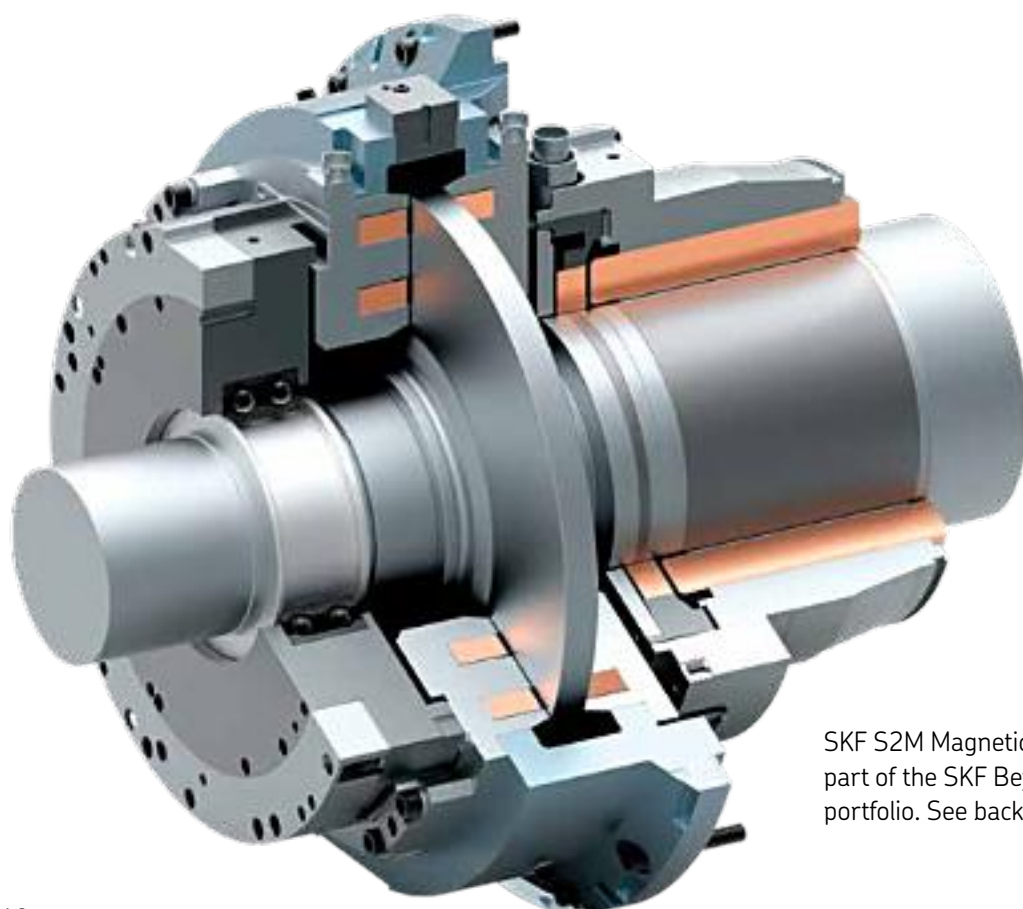

SKF S2M Magnetic Bearings are part of the SKF BeyondZero portfolio. See back cover for details.



Magnetic bearing controllers

Our newest system provides a fully digital control loop for remote monitoring and servicing of magnetic bearing applications. It has been developed to meet the demanding conditions of subsea compression stations, with a broad range of functionalities previously available only through secondary and tertiary systems. The controller's calculation core delivers an optimized control loop for turbo machines, proven on 30MW compressors and beyond. Real-time data is digitized through a high sampling rate and all data is available for post processing through the SKF software monitoring suite.

A new approach to commissioning

The benchmark for software solutions dedicated to magnetic bearing control and management, the SKF software suite significantly reduces time for system commissioning. Deployed on site or viewed remotely, it enables highly accurate, real-time monitoring for an immediate overview of data, trends and events.

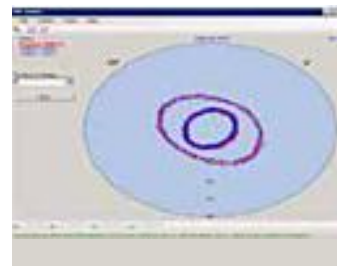

Orbits

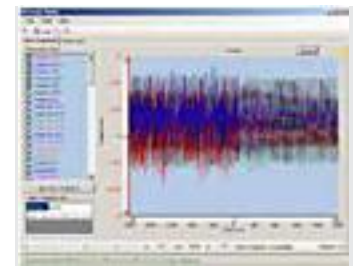

Trending

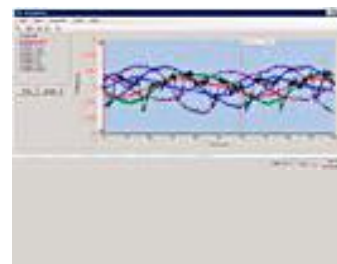

Time snapshots

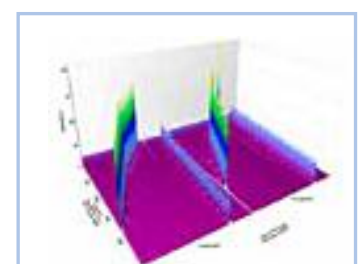

3D waterfalls



Lubrication management

A complete portfolio of lubrication solutions

More than a century of lubrication expertise

Like any mechanical system, moving parts in pumps, compressors, fans and blowers, generators and valves need proper lubrication to function optimally. SKF and Lincoln automatic lubrication systems deliver the exact quantity of the appropriate lubricant to the right place at the right time while the equipment is running – without production downtime.

With comprehensive knowledge of tribology and industrial demands, our engineers have developed lubrication systems for oil and gas applications with system components tailored to the demands of the industry.

Client needs analysis

SKF Client Needs Analysis – Lubrication Management will review your plant's lubrication practices. Typically, within a day, you will get a snapshot of your plant's situation based on answers to 40 questions.

SKF Lubrication Audit is an in-depth analysis of your plant's lubrication programme, usually taking several days to complete. You will get a report including the strengths and weaknesses of your current programme, your opportunities for improvement and a proposal for specific enhancement projects with a return-on-investment calculation.

Lubrication services

- Installation and start-up of centralized lubrication systems
- Servicing of existing centralized lubrication systems
- Lubricant suitability test for a centralized lubrication system
- Oil analysis

Lubrication software

SKF Lube Select can assist you in determining the most suitable grease for your bearings and working conditions.

SKF DialSet helps establish optimal relubrication intervals and lubricant quantities for any application. It also determines proper automatic lubrication system settings.

SKF Lubrication Planner helps you to develop and manage your lubrication plan.

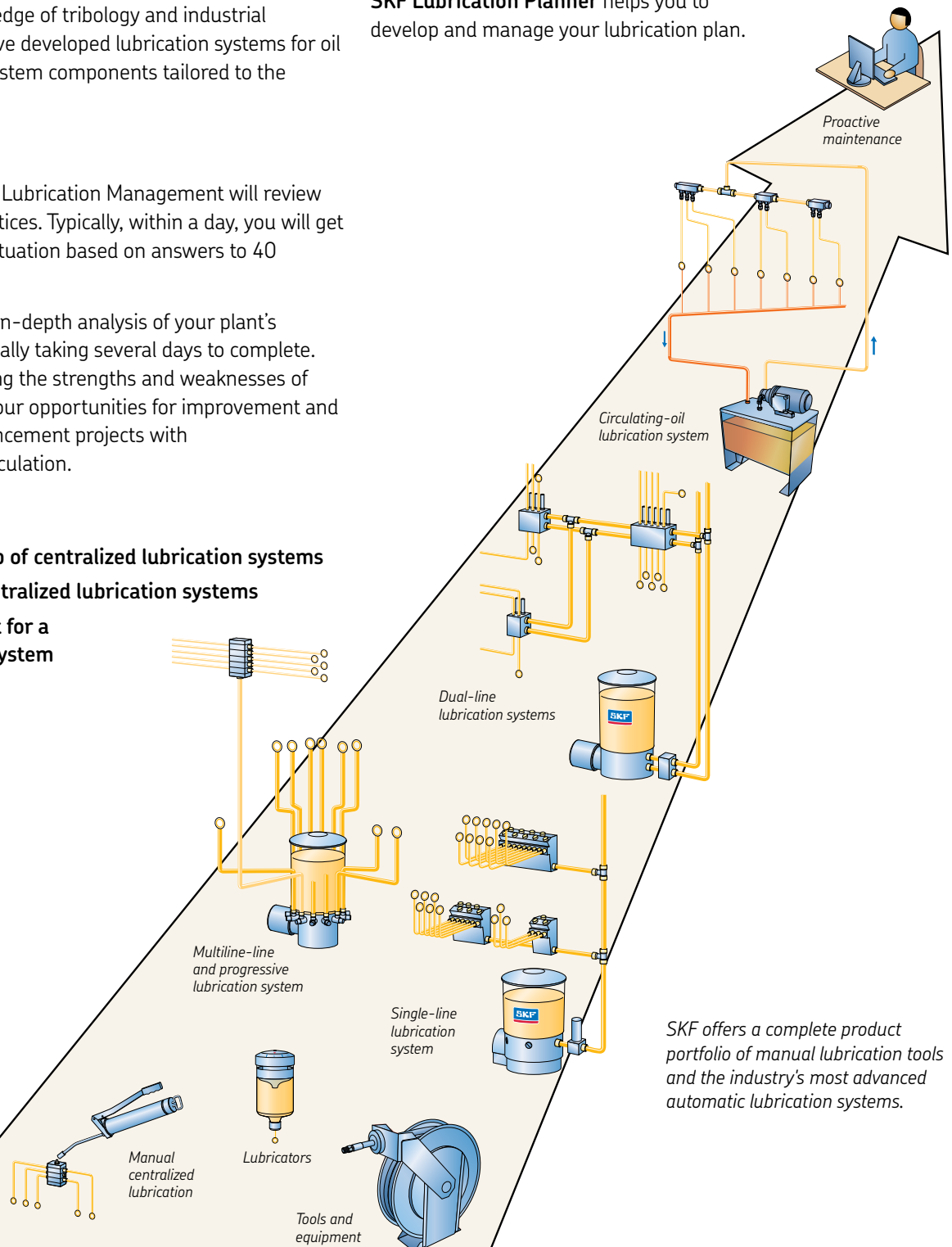

SKF offers a complete product portfolio of manual lubrication tools and the industry's most advanced automatic lubrication systems.

solutions to improve system reliability

SKF Circulating oil lubrication systems

These systems lubricate and cool heavily loaded bearings and are suitable for all size machines. They separate dirt particles, air bubbles and water from the oil. A pressurized oil system transports lubricant to the individually adjustable flow meters. Circulating-oil lubrication performs other functions. It stabilizes the lubrication points to the proper temperature, removes and filters wear particles from friction points, prevents corrosion damage, and removes water condensation. Additional benefits include integrated condition monitoring and demand-based distribution of lubricant.

Automatic oil mist lubrication systems

Carbon Shield is the new generation of Alemite atomized oil lubrication systems, matching your need for automated monitoring, and integration into operating systems. The Alemite Carbon Shield atomized oil lubrication system combines proven oil mist lubrication technology with state of the art control, monitoring and communications to provide reliable, cost effective bearing lubrication for pumps and motors in downstream plants. These systems can be designed for hazardous environments, meeting UL Class 1, Division 2 standards.

SKF centralized lubrication systems: The right lubricant quantity at the right time

SKF and Lincoln offer centralized, automatic lubrication systems for industrial applications to provide the exact lubrication needed for all lubrication points on your equipment while in operation. Benefits include:

- **Reduced downtime and production losses**
- **Extended bearing and machinery life**
- **Increased machine reliability and uptime**
- **Up to 50 percent reduction in lubricant consumption**
- **Reduced environmental impact caused by over lubrication**
- **Improved worker safety by reducing the need to work on and around machinery**

For machinery with many lubrication points, a centralized, automatic lubrication system will pay for itself, often in less than one year. Your SKF representative can put you in touch with the right SKF lubrication experts to meet your application needs.

SKF single point lubricators

A range of single point automatic lubricators filled with SKF grease provides small quantities of clean lubricant on a regular basis, thus improving bearing performance. In addition to improving safety, lubrication technicians can save considerable time with the use of SKF single point lubricators.



Grease- and oil-based automatic lubrication systems

Electric motor testing and monitoring

SKF is a leading provider of motor and motor/machine test and monitoring equipment for industrial maintenance professionals. SKF's motor test instruments are used in motor and machine maintenance organizations around the globe, and are the standard for motor testing that technicians and engineers depend upon.

Static motor analysis

The Baker AWA-IV static motor analyzers provide a full spectrum of motor tests for predictive motor maintenance and quality assurance. The Baker AWA-IV series of portable instruments perform automated tests on motor insulation strength and motor circuit integrity including:

- Surge
- Polarization index (PI)
- Dielectric analysis (DA)
- Winding resistance
- Megohm
- DC step voltage

These analyzers find problems that can lead to premature motor failures such as weak turn-to-turn insulation, dirt/moisture/chemical contamination, ground wall insulation weakness, shorts and opens, unbalances and misconnections, and lead-line cable issues. The Baker AWA-IV is fully automated, which makes it easy for maintenance technicians to use, but ensures integrity of repeated tests for any given motor or sets of motors. Users can save test data, generate test reports and identify trends that improve maintenance decision-making.

Portable dynamic motor monitoring

SKF pioneered the market for instrumentation designed to safely monitor motor health and performance while a motor is in operation. The EXP4000 is the latest generation of portable dynamic motor analyzers to provide maintenance professionals with the means to accurately troubleshoot mechanical vs. electrical problems with motors and the rotating equipment they drive. This analyzer performs:

- Load condition analysis
- Power condition analysis
- Torque signature analysis
- Continuous monitoring
- Vibration analysis
- VFD monitoring
- Motor efficiency assessments

On-line motor monitoring and analysis

The NetEP Online Motor Analysis System represents a breakthrough in the ability to monitor and manage critical motor health and performance from anywhere in the world with an Internet-connected computer. The NetEP is a permanently-installed networked device that can monitor up to 32 motors on a continuous basis. With the NetEP, maintenance personnel can:

- Continuously monitor with alerts on more than 100 parameters of motor health for each connected motor
- Connect to motors using up to seven different voltage busses
- Acquire time waveforms, torque/time waveforms and torque spectrum data
- Perform current signature analysis
- Acquire, monitor and analyze trend information to improve maintenance decisions



SKF Dynamic Motor Analyzer – EXP4000

SKF Static Motor Analyzer – Baker AWA-IV



SKF Online Motor Analysis System – NetEP



SKF EP1000 dynamic motor analyzer connector and accessories

Tools and technologies for maximizing the bearing life cycle



While every bearing has a pre-calculated service lifetime, research shows that not every bearing achieves it. When bearings fail to last for as long as they should, it is generally due to improper maintenance during key stages of the bearing life cycle: mounting, lubrication, alignment, basic condition monitoring and dismounting.

Organized according to these five bearing life cycle stages, SKF maintenance products reflect the range of maintenance tasks required for each stage. By applying the right maintenance practices and using the right tools, you can considerably extend your bearing's service life and increase plant productivity and efficiency.

Mounting / Dismounting

Includes a wide range of mechanical fitting tools, induction heaters and hydraulic equipment.

Lubrication

Includes SKF designed and certified bearing greases, manual lubrication tools, automatic lubricators, and lubrication accessories.

Alignment

Includes a comprehensive range of wireless shaft alignment tools, belt alignment tools and full range of machinery shims.

Basic condition monitoring

Includes easy to use instruments to either measure, monitor or detect temperature, sound, visual condition, speed, electrical discharge and vibrations that complement the full range of SKF condition monitoring solutions.



SKF Shaft Alignment Tools

Shaft misalignment is responsible for up to 50% of all costs related to rotating machinery breakdowns. To help save costs and ensure proper shaft alignment, SKF offers a range of accurate and easy-to-use shaft alignment tools.



SKF Thermal Cameras

To help detect potential problems at an early stage, an SKF Thermal Camera supports you to quickly and easily detect hot spots before they can cause a machine malfunction.



Bearing mounting tools

The comprehensive range of SKF bearing installation tools includes SKF Induction Heaters. With a low power consumption, these user-friendly tools offer a fast and safe heating solution for bearings and workpieces, both large and small.

Time- and money-saving coupling connection technologies

SKF OK Couplings reduce connection times for shafts and flanges

Mounting and dismounting shaft couplings can be time-consuming operations that take hours or even days to complete. SKF OK Couplings can significantly reduce the time required to connect rotating shafts and flanges in heavy equipment such as large gearboxes.



An SKF OK Coupling does not require a keyway in the shaft or hub to transfer the torques. This is a major savings and helps avoid shaft stress raisers. The couplings incorporate a thin tapered inner sleeve, designed to fit over the shaft, and a thick outer sleeve, with a taper matching that on the inner sleeve. Oil is injected at high pressure between the mating surfaces and the outer sleeve is driven up the inner sleeve with an integral hydraulic jack. Once correctly positioned, oil pressure is released and the resulting powerful interference fit enables high torques to be transmitted.

- **Easy, safe and quick to install**
- **Keyless**
- **Increased equipment performance**
- **Extended service life**
- **Reduced maintenance costs**
- **Reduced Mean Time to Repair (MTTR)**

SKF Supergrip bolts save time, cut costs and reduce risk of seizure

Based on the same design concept as OK couplings, SKF Supergrip bolts represent an improved technology for connecting rotating flange couplings and with proven reduction in coupling maintenance – from days to hours. Designed for insertion and removal by hand with initial clearance fits, SKF Supergrip bolts eliminate seized and jammed bolts. The need for an overhead crane and time-consuming hammering of bolts during insertion or extraction is eliminated.

Once the holes have been line-bored for the initial installation, there is no need for further reaming or boring of holes. Thus, SKF Supergrip bolts eliminate scheduling uncertainties during turnarounds caused by removing and installing coupling bolts.

And, compared with traditional bolt systems, SKF Supergrip bolts have higher torque capability due to our design concept. The bolt sleeve is hydraulically expanded to create an effective interference fit. And the bolt shank is hydraulically pre-tensioned for a precise, controlled fit. The combination creates a higher shear force capability and requires only a portable hydraulic pump to achieve. For disassembly the process is reversed and the bolt can be removed by hand.



Prominent steam turbine OEMs have standardized on SKF Supergrip bolts for many years because they offer high reliability, very high torque transmissibility and simplified serviceability. SKF can also engineer an upgrade of existing turbines. And field retrofits of other challenging downstream applications requiring high torque couplings and simplified maintenance have been achieved, for example, on large reciprocating process compressors. (See case study on page 33.)

SKF training solutions for management and maintenance personnel

SKF offers a wide range of training opportunities to customers, including management, operations and maintenance personnel. Venues range from training conducted on-site and in regional venues, to hands-on sessions at SKF Solution Factories.

SKF Training Solutions offers a comprehensive range of training courses designed to help plants eliminate machinery problems and achieve maximum reliability and productivity.

To help customers decide what training is required, SKF has developed an electronic assessment tool. The SKF Client Needs Analysis for Training will give a clearer perspective of staff competency and existing skill levels. The goal of the assessment is to provide useful and meaningful information to help focus on improvements for plant performance. SKF analysis can be conducted with individuals or with a group of staff members.

The course portfolio has been designed around the Asset Efficiency Optimization (AEO) workflow process, and has been created to allow participants to gain knowledge and expertise through a structured development path. Course categories include introductory, intermediate and advanced level training.

All available training options and local training schedules can be found in the Services section on skf.com.

Condition monitoring training

Through a real-life practical approach, these courses are designed for engineers and technicians whose responsibilities require proficiency in the use of SKF condition monitoring products. Product training courses focus on specific SKF condition monitoring products, while technology training courses cover the techniques and skills required to implement and utilize condition monitoring technologies.

On-site startup and long-term programme support

SmartStart is an on-site start-up service that focuses on getting your programme implemented efficiently.

Ongoing support can be provided as part of our Remote Diagnostic Services concept or a structured on-site mentorship to help you achieve the desired programme effectiveness.

Other training opportunities include formal vibration analysis certification courses in three levels to help your employees progress and develop competency in a structured learning environment. Periodic refresher training is available as technologies and processes change. And annual user group meetings and regional asset management conferences provide direct access to experts while sharing experiences with other industry users.

Knowledge Centre

The internet-based Knowledge Centre brings together in one place a wide array of resources to support the goals of our customers, both OEMs and end users. These range from industry benchmarks and reference materials to interactive web apps and e-learning.



SKF offers a wide range of training opportunities, both hands-on and virtual. On-line courses are ideal for many companies, in that the self-learning modules enable students to learn at their own pace and on their own timetable.

Case Study

SKF Operator Driven Reliability increased pump reliability and supported cultural change

The challenge

A large USA refinery was interested to involve operators in a pump reliability improvement programme. The MTBF of their pump fleet was <4 years versus a world class benchmark of >7 years. The maintenance and reliability team were challenged to achieve a sustained improvement without major investments in an extensive online monitoring system or in new pump configurations.

The SKF solution

SKF proposed a turnkey programme based on a concept it pioneered called Operator Driven Reliability. This structured programme addresses a range of technology, process and cultural issues, which create a shared objective between the operational and maintenance groups.

Equipping the operators with SKF Microlog Inspectors automated their inspection routines so they became more efficient and their day-to-day tasks more meaningful. SKF also designed the necessary work process improvements with linkage to an updated maintenance strategy along with IT infrastructure development. And, importantly, we closely supported the cultural change management needed to create an interdepartmental shared success.



The results

After 18 months of programme deployment, pump MTBF rose to 6 years, annual maintenance spend on pump maintenance was reduced by \$2 million and annual spend on mechanical seals was reduced by \$310 000. These improvements were sustained over a period of years, including the cultural transformation towards shared success between operations and maintenance.

SKF Maintenance strategy upgrade project contributes to OEE increase

The challenge

A large synthetic crude oil refinery needed to align their maintenance strategy with their shifting business goals. The reliability processes managed by internal consultants and external contractors had not been efficient and were proving too labor intensive. Conversion to a new CMMS system was also underway but the predictive maintenance module of the system was essentially an empty shell that needed to be populated to have value. The quality of a previous deliverable of similar scope by SKF to a sister facility led them to ask for a proposal.

The SKF solution

SKF put together a tailor-made offer based on the customer's specific needs. The offer followed the structure of the SKF Asset Efficiency Optimization model (see page 4-5) and encompassed: maintenance strategy review based on SKF RCM methodology; criticality analysis; task selection; job plan development; CMMS population and SKF Spare Parts Alignment, Rationalization & Optimization (SPARO) suited to new programme.



The results

SKF provided the customer with maintenance practices according to the criticality of their assets and their business goals. SKF offered competitive and cost effective solutions compared to the customer's current practices, based upon their business goal to increase OEE by 1%. The project was completed on time and within budget. Savings created from the SPARO facet alone nearly offset the investment cost of the project. Efficiency improvements after project implementation continue to track well with the original objective.

Improving refinery OPEX by increasing asset efficiency

The challenge

A mid-sized North American refinery was operating an on-site power plant based on a gas turbine generator set that was rated for 52 MW capacity, but was only able to achieve 40 MW output. To make up the difference, the refiner needed to purchase 12 MW per day from the local utility. The local maintenance staff was unable to achieve more output due to high turbine vibration levels whenever the output was increased beyond 40 MW.



The SKF solution

An SKF on-site reliability contract engineer was embedded in the operational team and performed a full rotordynamic analysis of the gen set, including the influence of operating parameters on the its vibration characteristics. After this thorough review, an adjustment of operating procedures was recommended to rectify the suboptimal turbine performance.

The results

Once the SKF recommendation was implemented, the refinery was able to increase and sustain power output to 52 MW and still remain within acceptable vibration limits. This significant improvement was achieved with no other equipment changes necessary. As a result the refinery was able to avoid external purchase of power, which created savings of \$100,000 per week and \$5 million per year – on a sustained basis.

SKF monitoring system enables fulfillment of Reliability Centered Maintenance (RCM) update

The challenge

A major downstream chemical plant commissioned an updated RCM study, which recommended online monitoring be applied to semi-critical machines. These assets were targeted as candidates for improved maintenance planning and life cycle cost reduction, using a better condition monitoring strategy with more frequent data collection. The 35 machines in this category had previously been monitored with portable vibration analyzers in a periodic programme with monthly readings. The chemical plant had limited funds available to do the necessary technology upgrade.

The SKF solution

SKF proposed its Multilog DMx online system along with installation and startup assistance. The system integrated into the customer's existing Predictive Maintenance and Operator Driven Reliability programme that were already supplied by SKF.

The SKF Multilog DMx is rated for hazardous area installation in ATEX Zone 1, NEC Class 1 Div 1 with sensors mounted in Zone 0. This allowed mounting directly onto the machine skids without need for explosion-proof housings and multiple barrier strips. Configuration for both fluid film bearings and rolling element bearing machines stipulated by the RCM study was also possible.

The results

Due to small footprint of the DMx and the agency ratings it meets, the system installation was considerably less expensive than another online monitoring system customer could have installed. Data integration with the existing SKF @ptitude software suite for the PdM and ODR programme increased the efficiency of the reliability team. Integration of the data stream to the distributed control system in the plant was also seamless.



Case Study

Structured reliability performance contract allows refinery to meet margin expectations

The challenge

A moderate-size European refinery with integrated electricity generation experienced a change in ownership with the requirement to dramatically reduce their total maintenance cost. They had already undergone attrition of some of their most experienced staff and were struggling with how to cope while still maintaining high availability and operational targets.

After a positive 5-year experience with SKF Proactive Reliability Maintenance (PRM) – a structured programme combining predictive maintenance with RCFA – the refinery asked SKF to propose increasing the contract scope so they could retain the reliability improvements they had experienced and allow the remaining staff to focus on an upgrade project.

The SKF solution

SKF offered a 3-year Integrated Maintenance Solution (IMS) which included vibration analysis, alignment, thermography, motor diagnostics, bearing RCFA, engineering support, lubrication programme management, MRO spares management, machine technology upgrades, mechanical services and complete bearing and housing supply chain management. This type of high skill / high impact performance contract has been successfully applied by SKF in other process industries.



Key Performance Indicators (KPIs) were established along with the use of the SKF Documented Solution Programme (DSP) as a contract management tool to track cost savings and performance against the KPIs.

The results

All contract KPIs have been met, including further improvements in overall reliability, process availability and HSE factors. The refinery margin expectations of the new ownership have been achieved.

SKF online motor monitoring helps industrial gas company fulfill performance contract

The challenge

A North American supplier of industrial gas was operating under a stringent supply contract to a major downstream facility. The terms of the contract had several performance requirements for which the gas supply company was liable if they did not meet the terms. The reliability of their fleet of 30 large electric motors (500 – 1 000 HP) were critical to fulfillment of the contract terms.

The existing solution was to monitor the motors on a periodic basis with a portable motor current analyzer, which required workers to physically place motor current clamps on each motor individually. Only data “snapshots” from these periodic readings were available with this method.

The SKF solution

SKF installed our Baker NetEP system that could be safely mounted in the motor control center, providing a stream of online motor data to a central monitoring center (local or remote). The online system is capable of capturing over 15 motor parameters with much higher data resolution than is possible with a portable instrument.



The results

Workers were no longer exposed to the hazards of collecting data around large electrical motors and the customer was able to monitor motor condition online via their remote diagnostic center. Motor reliability was steadily improved. They also were able to correlate process changes that manifested themselves as changes in motor parameters (torque, power consumption, etc.). This allowed them to further optimize process performance and helped them fulfill their supply contract by looking through a “window” they had never looked through before.

New Latin American ethylene plant selects SKF S2M bearings for turboexpanders

The challenge

One of the largest petrochemical firms in the Americas known for implementing green technologies was planning to build a “World Class” ethylene plant. The EPC for this project specified cryogenic turboexpanders for liquid separation. Based on previous experience, they specified SKF S2M Magnetic Bearings for these units in order to keep oil from contaminating the process and to provide the lowest life cycle cost.

The SKF solution

Active magnetic bearings (AMB) eliminate the need for lubrication systems and the possibility for contaminating heat exchangers and process piping. For many applications, including ethylene recovery, magnetic bearings have lower capital cost compared to high pressure API lubrication systems. In addition, the monitoring and protection system embedded within the magnetic bearing controller provides end users and OEMs with the necessary diagnostic information to support the turboexpanders throughout the assets’ life cycle. Magnetic bearing systems provide extremely high reliability and availability and are often selected for critical applications.

Drawing from our experience with hundreds of turboexpander projects, SKF S2M Magnetic Bearings has standardized its range of active magnetic bearings so that turboexpander OEMs can quote with very little engineering support and with manageable lead times.



The results

The EPC, OEM and end user met the project timeline and CAPEX objectives for the project for four large cryogenic turboexpanders with magnetic bearings. In the end, the OEM decided to make a volume purchase of 10 magnetic bearing systems which saves costs and also provides a stock of lower cost systems for future projects that have already been identified. Once commissioned, the “World Class” ethylene plant will realize OPEX benefits from highly reliable systems, high operating efficiencies and with the flexibility to manage both cold starts and process adjustments as required by operational considerations.

SKF solves oil flooded screw compressors problem for OEM and end user

The challenge

A large OEM and packager of oil flooded screw compressors used in the vapor recovery unit of refineries processing highly corrosive sour gas was experiencing very low reliability at several locations. Their refinery customers were experiencing <3 months Mean Time Between Repair (MTBR), resulting in production losses for each event along with significant repair costs. One refinery was in the midst of a CAPEX requisition to bring on redundant capacity so they could meet their operating targets. As an alternative they were considering a dry screw compressor design, which had better reliability but with higher CAPEX.

The SKF solution

SKF worked with the end user and OEM to conduct a detailed application review, including Root Cause Failure Analysis (RCFA), Finite Element Modeling (FEM) along with a detailed investigation into the bearing system tribology, material selection and internal geometry. A completely redesigned bearing was proposed, including SKF silicon nitride ceramic rolling elements, proprietary super-tough stainless steel rings and an engineered PEEK polymer cage.

The results

The new bearing arrangement was a drop-in replacement for the existing fleet, requiring no rework by the OEM or end user. The compressor MTBR was extended to >2 years, thereby creating improvements in OPEX



along with major increases in production throughput. The refinery was able to cancel the CAPEX for additional compressor capacity and the OEM improved the viability of their product line in the demanding market for sour gas compression.

Case Study

SKF commissions large integrated protection and condition monitoring system for Asian refinery

The challenge

An existing refinery in Asia required upgrading of their plant-wide machinery protection and condition monitoring surveillance systems. For the protection system they required SIL 2 Safety Integrity Level 2 (SIL2). The project was to be handled as a turnkey contract administered by an EPC. Scope of supply included critical machines, semi-critical machines and balance-of-plant equipment, consisting of hundreds of machines and thousands of measurement points.

The SKF solution

SKF managed the complex proposal by aligning needs of the EPC and end user and creating a project management structure to ensure tight integration of the architecture along with a competitive bid level. Drawing from our comprehensive range of sensors, online and portable monitoring hardware and software, the project team engineered a solution that met the timeline requirements and the local support stipulations for the project. The scope included:

- Engineering
- Prefabrication
- Testing (FAT, iFAT and SAT)
- Transportation
- Installation
- Commissioning



The results

The entire system was engineered, prefabricated and tested by the local SKF service center and was commissioned on schedule and within budget. Data integration with the plant's control and CMMS systems across the refinery – from critical machines through balance-of-plant equipment monitored with SKF portable data collectors – dramatically improved efficiency of the customer's reliability engineering team. It also provided timely information essential for critical operational decisions. And the ability to provide responsive local support across all machine classes will be the cornerstone to meet the refinery's long term objectives for improved plant safety and increased reliability.

For solution information, refer to condition monitoring architecture on page 15.

SKF provides optimized oil mist system for new Middle East project

The challenge

An Engineering Procurement Construction (EPC) company requested a bid from SKF for a centralized lubrication system based on oil mist for over 100 API process pumps. The tender documents specified six oil mist generators to provide adequate lubrication to the rolling element pump bearings. The system design was an historic carryover from the end customer's standards for systems deployed earlier.

The SKF solution

Collaborating with SKF pump bearing lubrication specialists we recalculated the lubrication requirements based on the latest SKF bearing standards. Working closely with the engineering department of the final customer and the EPC, we recommended to change the system architecture by adding a modern control system and to re-size the system based on recalculation of actual bearing lubrication requirements.

The results

The customer was able to reduce scope to 4 from 6 mist generator systems creating a significant savings on CAPEX. And, by adopting our recommendation for flow rates and an upgraded control system, the oil consumption was dramatically reduced while system reliability was increased, which will bring OPEX improvements that are cumulative over the life of the facility. The resulting savings easily offset the cost of the original investment.



Coupling upgrade improves operational efficiency of process compressor

The challenge

A crude oil and chemical complex was reliant on a large reciprocating compressor and drive motor equipped with a rigid flange coupling designed to handle the very high torque requirement. During a unit turnaround, it was discovered that the fitted bolts of the flange coupling had experienced fretting corrosion at the bolt diameter / bolt hole interface. Forced removal of bolts resulted in scouring of several bolt holes. Re-boring of the holes to clean up the damage would limit options for future contingencies.



A detailed FEM study was conducted to verify that the SKF solution would have adequate shear strength to meet the torque requirement in the presence of pulsating loading. An SKF line boring service (needed only once) was included to accelerate the field conversion and get the compressor back on line.

The SKF solution

SKF turbomachinery and coupling experts worked closely with the machine builder and end user maintenance team to recommend the application of SKF Supergrip Bolts. Based on the principle of hydraulic mounting pioneered by SKF, this solution has been applied for many years in large steam and gas turbine couplings with very high torque capability. (See page 26 for a detailed explanation of the principle behind SKF Supergrip Bolts.)

The results

The conversion was accomplished efficiently within the project timeline and inspected after one year of service to ensure coupling and bolt integrity. Several other units at the site were also converted with no operational or maintenance issues reported.

Structured RCFA programme helps refiner improve naphtha recovery process

The challenge

A very large Latin American refinery was experiencing operational issues created by reliability of the naphtha gas recovery unit within its oil dehydration process and with subsequent impact on its crude oil heating system. Frequent failures of the system were reducing oil pumping capacity to the neighboring facility. Refinery maintenance personnel could isolate the problem to the naphtha compressor but were not able to pinpoint the actual source of the problem nor develop remedial actions.



The SKF solution

SKF applied a pragmatic and well-structured RCFA methodology, drawing upon historical records, operational parameters, physical evidence and interviews of key personnel. Once the logic tree was constructed and all variables had been verified that could have an impact on the compressor performance, an action plan was developed to aim directly at mitigating the root cause of the bearing failures. During this process a very comprehensive study of the compressor vibration with high resolution data was used to associate bearing loading with process conditions along with a detailed review of the oil lubrication delivery and filtration systems.

The results

All necessary improvements were made to the bearing and lubrication systems, which led directly to the desired reliability and performance of the naphtha system. Detailed revisions to the repair, assembly and operational manuals and CMMS records were made to secure the improvements. Dramatic reduction in naphtha gas venting was realized along with resumption of full pumping capacity to their sister facility.

SKF Solution Factory: a local gateway to SKF capabilities

Applying a unique mix of resources to address your challenges



To provide our customers with direct access to SKF's global capabilities, SKF has created a unique concept: SKF Solution Factory.

Here, under one roof, we offer a wide range of specialized services that draw on all of our core competencies and industry-specific knowledge.

An SKF Solution Factory is a place where customers can come to solve difficult application challenges, consult with lubrication specialists, have a custom machined seal designed and manufactured on the spot, or explore design options with SKF engineers using knowledge-engineered software that functions as a virtual test rig.

Typically, an SKF Solution Factory also offers bearing remanufacturing and spindle repair services, training and total shaft solutions including expert mounting, alignment and balancing. And depending on location, customers can also take advantage of remote condition monitoring and expert diagnostics.

By combining multiple areas of expertise, an SKF Solution Factory is able to provide integrated, value-added solutions to customers, whether they are designing a new piece of equipment or working to optimize plant asset efficiency. The network of SKF Solution Factories is continually expanding, making customized SKF services and solutions available to more customers worldwide.



The network of twenty-five SKF Solution Factories are conveniently located in or near many of the downstream market centers around the world.



*See inserts for more details
about SKF solutions for traditional
energy production.*



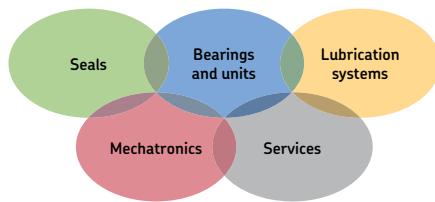

The Power of Knowledge Engineering

Combining products, people, and application-specific knowledge, SKF delivers innovative solutions to equipment manufacturers and production facilities in every major industry worldwide. Having expertise in multiple competence areas supports SKF Life Cycle Management, a proven approach to improving equipment reliability, optimizing operational and energy efficiency and reducing total cost of ownership.

These competence areas include bearings and units, seals, lubrication systems, mechatronics, and a wide range of services, from 3-D computer modelling to cloud-based condition monitoring and asset management services.

SKF's global footprint provides SKF customers with uniform quality standards and worldwide product availability. Our local presence provides direct access to the experience, knowledge and ingenuity of SKF people.



SKF BeyondZero is more than our climate strategy for a sustainable environment: it is our mantra; a way of thinking, innovating and acting.

For us, SKF BeyondZero means that we will reduce the negative environmental impact from our own operations and at the same time, increase the positive environmental contribution by offering

our customers the SKF BeyondZero portfolio of products and services with enhanced environmental performance characteristics.

For inclusion in the SKF BeyondZero portfolio, a product, service or solution must deliver significant environmental benefits without serious environmental trade-offs.

SKF S2M Magnetic bearings are part of the SKF BeyondZero portfolio, which includes products and solutions with significant environmental benefits, because they reduce energy consumption and lubricant use compared to other bearings used in oil and gas applications.

® SKF is a registered trademark of the SKF Group.

© SKF Group 2014

The contents of this publication are the copyright of the publisher and may not be reproduced (even extracts) unless prior written permission is granted. Every care has been taken to ensure the accuracy of the information contained in this publication but no liability can be accepted for any loss or damage whether direct, indirect or consequential arising out of the use of the information contained herein.

PUB 75/S2 14842 EN · July 2014

Certain image(s) used under license from Shutterstock.com