



New Generation
SCP² PET SHOCK ABSORBERS
For PET Container Industry



Ideal for Stretch Rod and Mold Applications

Increase Cycle Rates
Increase System Performance
Reduce Damage-Causing Impact Forces



PET Shock Absorbers

Ideal for Stretch Rod and Mold Applications



Model SCP 650ML-1-QCM-FG
Quick-Change Mount Shock
Shown actual size

PET Shock Absorber Benefits

- Increased production
- Increased system performance
- Increased shock absorber life
- Reduced downtime
- Reduced reaction forces
- Reduced cross contamination issues with H1 oil
- Reduced component wear
- Reduced damage-causing impact forces
- Solves previous form and fit issues
- Lifetime warranty against material and workmanship
- Highly cost-competitive

ACE Controls now offers a **NEW GENERATION** of industrial shock absorbers for the PET container industry. These durable models are ideally suited for stretch rod and mold applications on Sidel and KRONES production machines.

This versatile line of ACE PET shock absorbers includes the dual benefits of soft contact and self-compensating performance, allowing for reaction to changing conditions without adjustment. In addition, the effective weight is now configurable, adding even more application capability to these rugged performers.

PET shock absorbers from ACE include H1 food grade oil, USDA, FDA, and NSF approved. Numerous models now include a rear female hex design for ease and speed of installation.

ACE PET shock absorbers allow production machinery to run faster and longer with considerably reduced reaction forces, reduced component wear and reduced downtime.



Lifetime Warranty

ACE Controls Inc. products are guaranteed to be free of defects in materials and workmanship. ACE will repair or replace any of its products determined to have a defect in materials or workmanship at any time for the life of the product.

PET Shock Absorber Features

- Initial soft-contact
- Fast through-stroke time
- Quick change capability on SCP 650ML-1-FG-QCM-880 model
- Rugged design to handle stretch rod applications
- Hardened steel high pressure inner tube
- Effective weight is now configurable
- H1 food grade oil, USDA, FDA, and NSF approved

PET Shock Absorbers

Machine Type and Applications

- Machines have a carousel style rotating base.
- They can have from 4 to 48 Mold stations.
- The mold accepts a heated PET preform, closes and engages a shock.
- The stretch rod stretches the preform and then strikes the shock at end of stroke.
- After the bottle has been sized, the stretch rod is then retracted. On some machines there is a shock for the up direction.
- Mold opens and the bottle is ejected
- Shock applications are the mold close, stretch rod down and stretch rod up positions on some machines

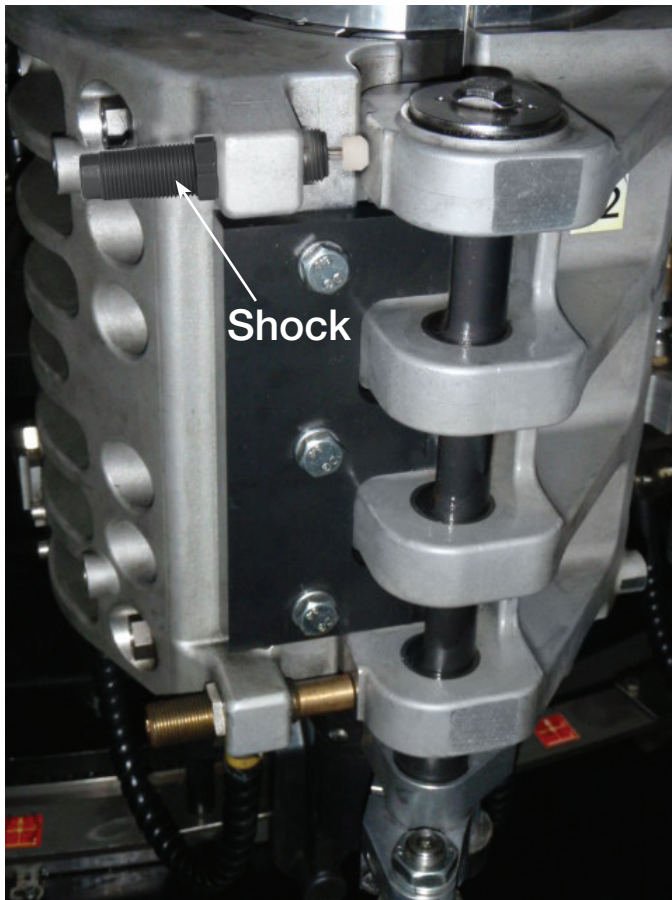
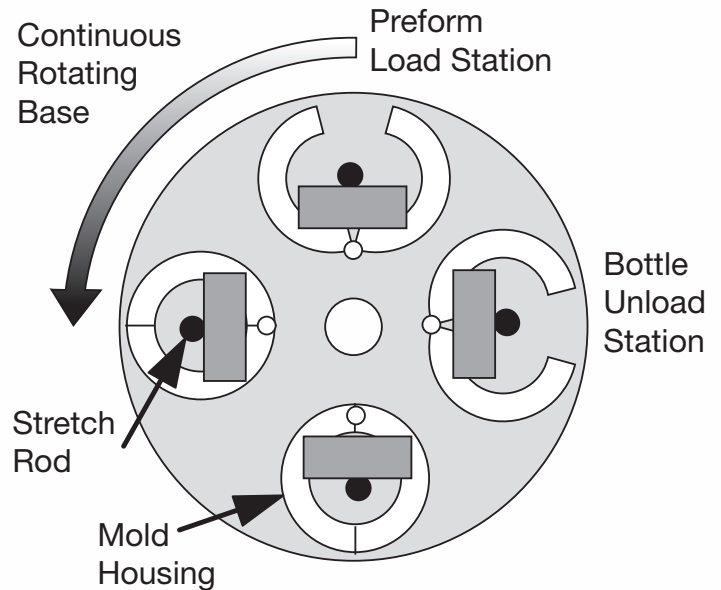

Mold Shown in Closed and Locked Position

The application image on the left shows the mold in the closed and locked position. In this application, the shock absorber is mainly used as a snubber. The shock tightens any slack in the mechanical linkages and prevents the mold halves from hammering each other.

PET Shock Absorbers

Machine Type and Applications Continued



The PET application image on the left shows the stretch rod slide, shock absorber, shock holder and in this case a height stop column.

In this particular application, the machine only has a stretch down and a mold shock absorber

3

PET Shock Absorbers Construction

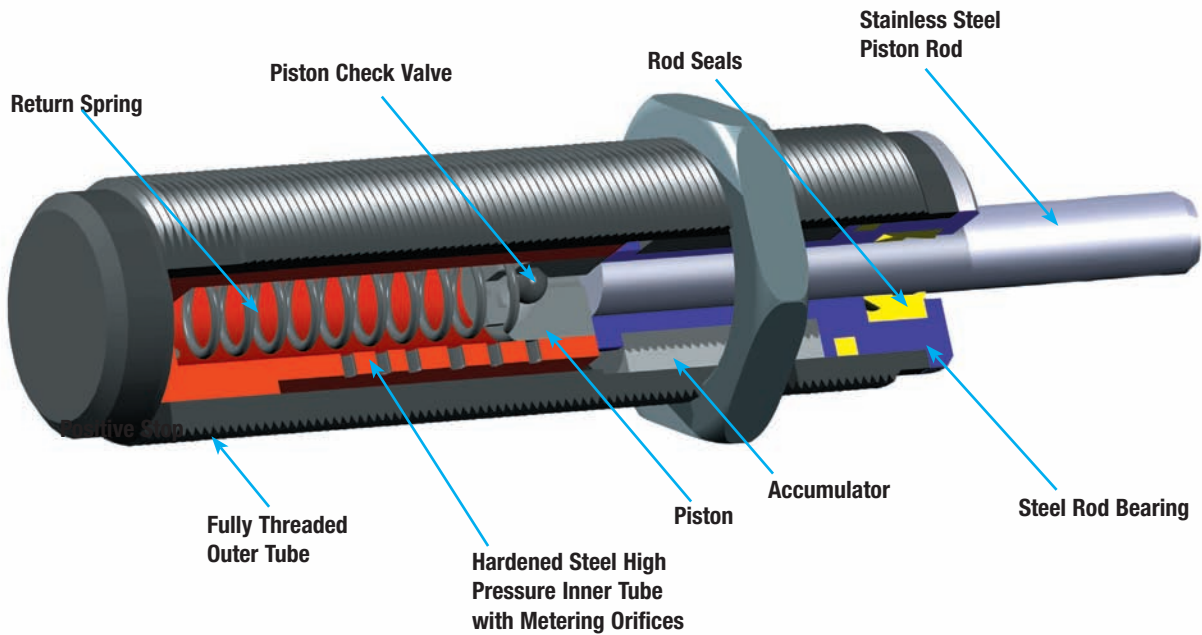

Application: Sidel Series 1, 2 & Universal Machines

Dimensions in inches (millimeters)

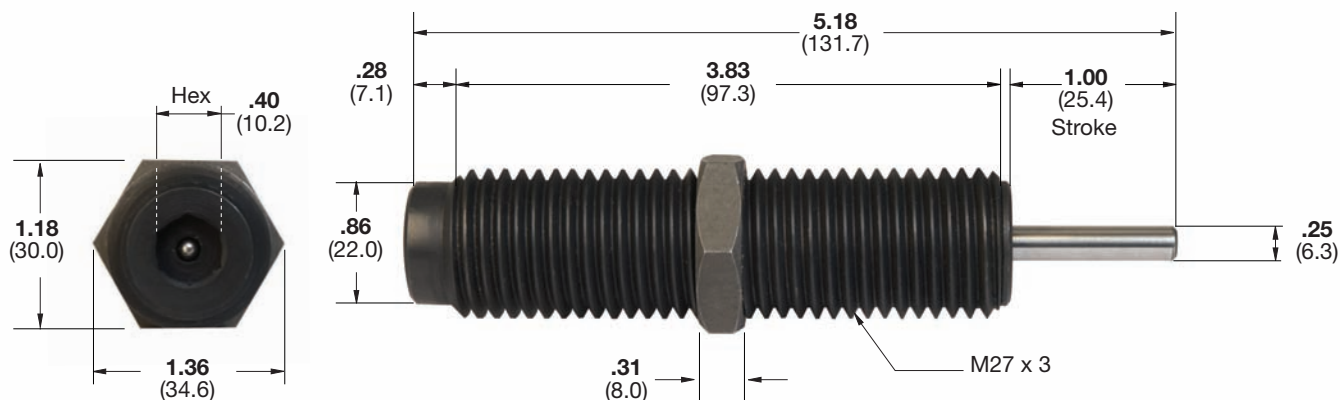

Specifications

Model	Effective Weight (stiffness)	E_3	E_4	Return Force lbs (N)	Return Time sec	Shipping Weight lbs (kg)
		Energy per Cycle in lbs (Nm)	Energy per Hour in lbs/hour (Nm/hour)			
SCP 650ML-1-FG-NB	(-1) Ultra Light	650 (73)	600,000 (68,000)	2.40 - 6.87 (10.67 - 30.55)	0.20	0.67 (0.31)
SCP 650ML-3-FG-NB	(-3) Medium					

Technical Data

- Impact velocity range:** 0.5 to 12 ft/sec (0.15 to 3.66 m/sec)
- Mechanical stop:** integral mechanical stop built into front of units
- Oil type:** (-FG) H1 food grade oil, USDA, FDA & NSF approved
- Materials:** steel body with Weartec Plus finish. Stainless steel piston rod
- Effective weight:** selectable
- Rear female hex:** for ease and speed of installation
- Mold applications:** Sidel Series 1, 2 and Universal machines with large molds
- Stretch applications:** Sidel Series 1, 2 and Universal machines without a shock holder

Ordering Information - All Models

SCP 650ML -1 -FG -QCM-880

SCP ² Series & Model Number	Effective Weight	Oil Type	Mount, Button Options
SCP 190ME-3-439	-1 Ultra Light	-FG Food Grade H1	SCP 190ME (NO Options) SCP 300M (NO Options) SCP 650ML Options: -QCM Quick Change Mount (For Series 2 Machines Only) -ERSB Extended Rod, Small Button -SBUC Small Button, Urethane Cap -880 No Button, Standard Rod -NB No Button, Short Rod
SCP 300M	-2 Light		
SCP 650ML	-3 Medium		
	-4 Heavy		

95% of applications will be handled by (-1 & -3) effective weight models. Consult ACE Controls or your distributor for information on (-2 & -4) effective weights, if required.

Application: Sidel Series 2 & Universal Machines

Dimensions in inches (millimeters)

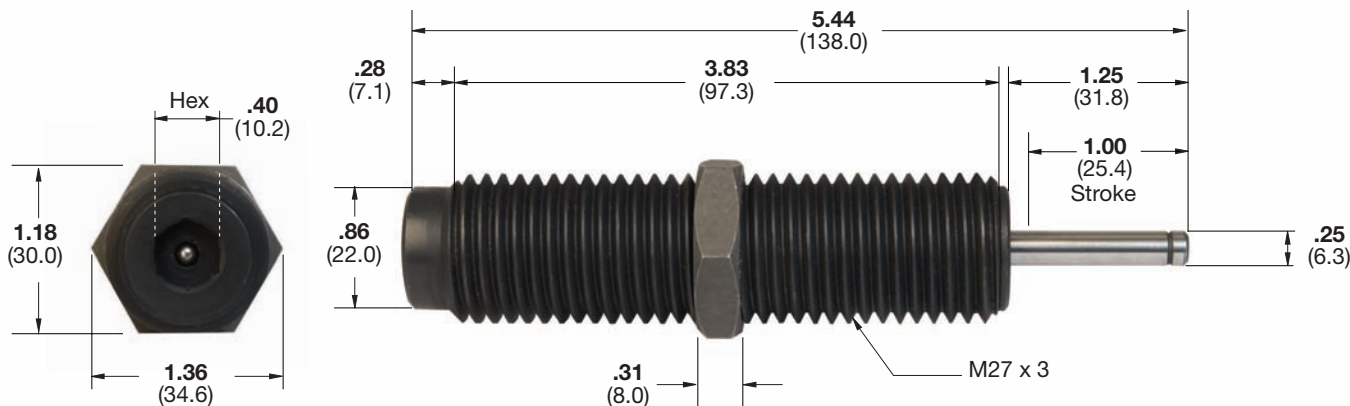

Specifications

Model	Effective Weight (stiffness)	Energy		Return Force lbs (N)	Return Time sec	Shipping Weight lbs (kg)
		E ₃ Energy per Cycle in lbs (Nm)	E ₄ Energy per Hour in lbs/hour (Nm/hour)			
SCP 650ML-1-FG-880	(-1) Ultra Light	650 (73)	600,000 (68,000)	2.40 - 6.87 (10.67 - 30.55)	0.20	0.67 (0.31)

5

Sidel Universal Shock Holder



Sidel Series 2 Shock Holder (P/N 1131136901)

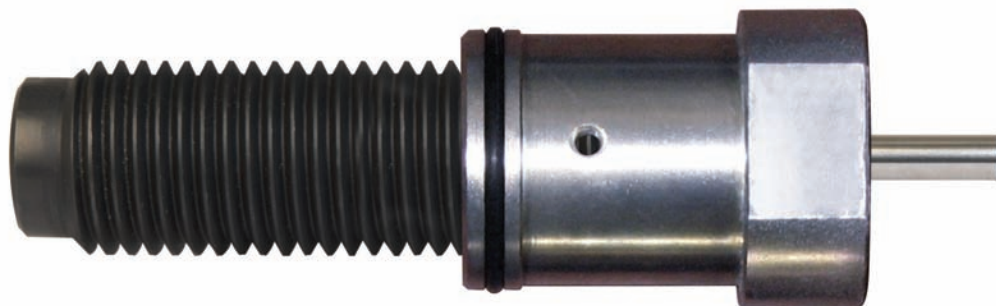

Technical Data

Impact velocity range: 0.5 to 12 ft/sec (0.15 to 3.66 m/sec)

Mechanical stop: integral mechanical stop built into front of units. Shock holder becomes a positive stop.

Oil type: (-FG) H1 food grade oil, USDA, FDA & NSF approved

Materials: steel body with Weartec Plus finish. Stainless steel piston rod.

Effective weight: selectable

Rear female hex: for ease and speed of installation

Sidel Series 2 stretch application: used only with shock holder part number 1131136901

Sidel Universal stretch rod application: used with all shock holders

Application: Sidel Series 1 & 2 Machines

Dimensions in inches (millimeters)

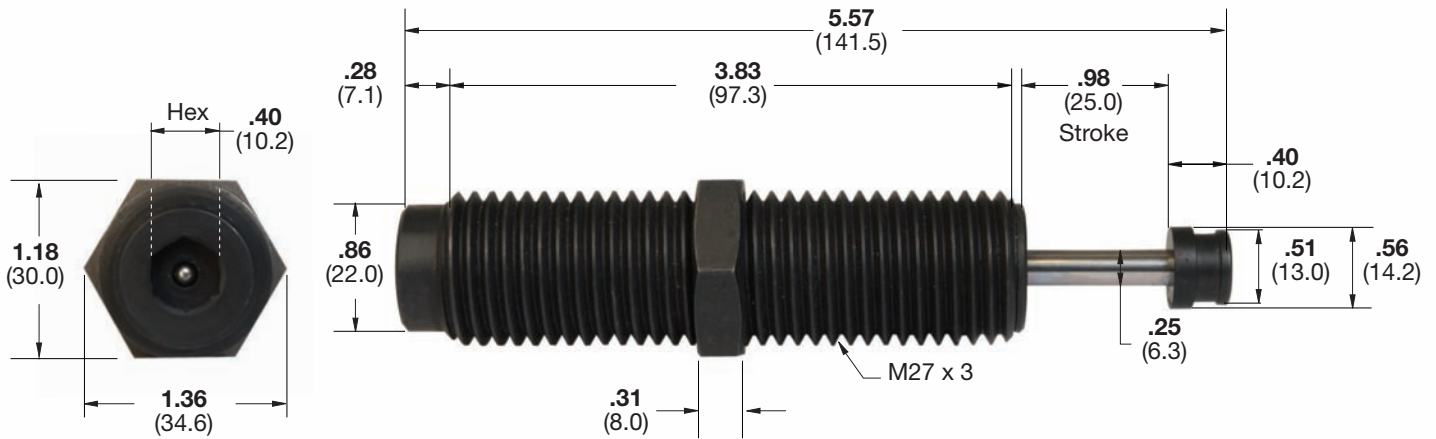

Specifications

Model	Effective Weight (stiffness)	E_3 Energy per Cycle in lbs (Nm)	E_4 Energy per Hour in lbs/hour (Nm/hour)	Return Force lbs (N)	Return Time sec	Shipping Weight lbs (kg)
SCP 650ML-1-FG-ERSB	(-1) Ultra Light	650 (73)	600,000 (68,000)	2.40 - 6.87 (10.67 - 30.55)	0.20	0.67 (0.31)

Sidel 1 Shock Holder (one of several types)



Sidel Series 2 Shock Holder (P/N 1073679102)



Technical Data

Impact velocity range: 0.5 to 12 ft/sec (0.15 to 3.66 m/sec)
Mechanical stop: integral mechanical stop built into front of units. Shock holder also becomes a positive stop.
Oil type: (-FG) H1 food grade oil, USDA, FDA & NSF approved
Materials: steel body with Weartec Plus finish. Stainless steel piston rod.

Effective weight: selectable
Rear female hex: for ease and speed of installation
Sidel Series 1 stretch rod application: all that use shock holders
Sidel Series 2 stretch rod application: used only with shock holder part number 1073679102

Application: KRONES Machines

Dimensions in inches (millimeters)

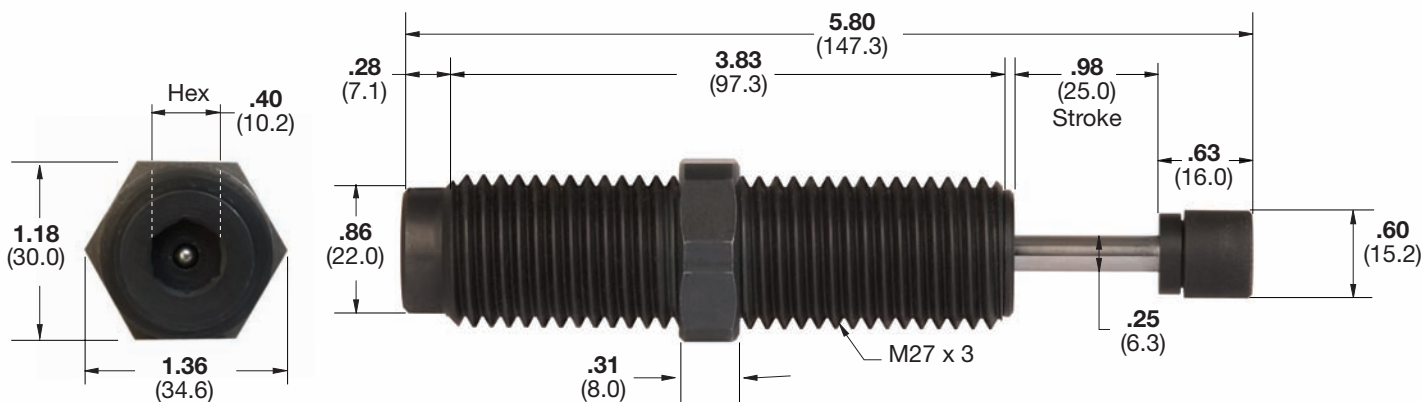

Specifications

Model	Effective Weight (stiffness)	Energy per Cycle in lbs (Nm)	Energy per Hour in lbs/hour (Nm/hour)	Return Force lbs (N)	Return Time sec	Shipping Weight lbs (kg)
SCP 650ML-1-FG-SBUC	(-1) Ultra Light	650 (73)	600,000 (68,000)	2.40 - 6.87 (10.67 - 30.55)	0.20	0.67 (0.31)

7

Technical Data

Impact velocity range: 0.5 to 12 ft/sec (0.15 to 3.66 m/sec)
Mechanical stop: integral mechanical stop built into front of units
Oil type: (-FG) H1 food grade oil, USDA, FDA & NSF approved
Materials: steel body with Weartec Plus finish. Stainless steel piston rod.

Effective weight: selectable
Rear female hex: for ease and speed of installation
Applications: KRONES stretch rod with unit shock holders

SCP 300M3-B-FG

Dimensions in inches (millimeters)

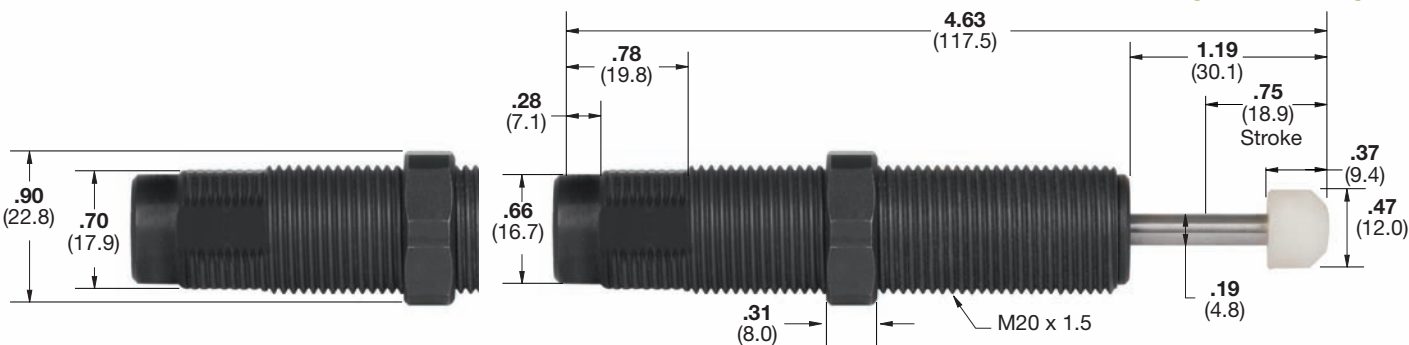

Specifications

Model	Effective Weight (stiffness)	Energy per Cycle in lbs (Nm)	Energy per Hour in lbs/hour (Nm/hour)	Return Force lbs (N)	Return Time sec	Shipping Weight lbs (kg)
SCP 300M3-B-FG	(-3) Medium	300 (33)	400,000 (45,000)	1.05 - 2.15 (4.67 - 9.56)	0.10	0.25 (0.11)

Technical Data

Impact velocity range: 0.5 to 12 ft/sec (0.15 to 3.66 m/sec)
Mechanical stop: integral mechanical stop built into front of units
Oil type: (-FG) H1 food grade oil, USDA, FDA & NSF approved

Materials: steel body with Weartec Plus finish. Stainless steel piston rod.
Effective weight: selectable
Applications: KRONES large molds

Application: Sidel Series 2 Machines

Dimensions in inches (millimeters)

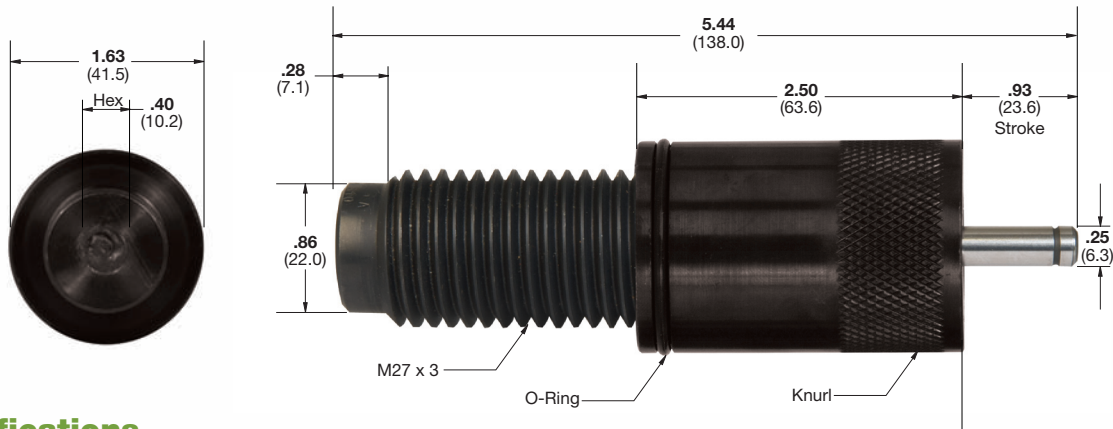

Specifications

Model	Effective Weight (stiffness)	Energy per Cycle in lbs (Nm)	Energy per Hour in lbs/hour (Nm/hour)	Return Force lbs (N)	Return Time sec	Shipping Weight lbs (kg)
SCP 650ML-1-FG-QCM-880	(-1) Ultra Light	650 (73)	600,000 (68,000)	2.40 - 6.87 (10.67 - 30.55)	0.20	0.67 (0.31)

Technical Data

Impact velocity range: 0.5 to 12 ft/sec (0.15 to 3.66 m/sec)

Operating temperature: 32° to 150° F (0° to 66° C)

Mechanical stop: integral mechanical stop built into front of units

Oil type: (-FG) H1 food grade oil, USDA, FDA & NSF approved

Materials: steel body with Weartec Plus finish. Stainless steel piston rod.

Effective weight: selectable

Sidel Series 2 application: stretch rod down only

SCP 190ME3-439

Application: Sidel Universal Machines-Small Molds

Dimensions in inches (millimeters)

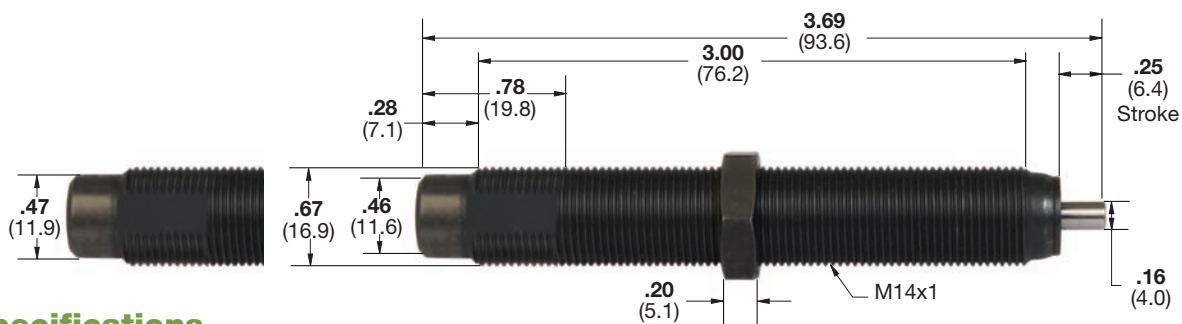

Specifications

Model	Effective Weight (stiffness)	Energy per Cycle in lbs (Nm)	Energy per Hour in lbs/hour (Nm/hour)	Return Force lbs (N)	Return Time sec	Shipping Weight lbs (kg)
SCP 190ME3-439	(-3) Medium	225 (25)	300,000 (34,000)	0.90 - 1.90 (4.00 - 8.95)	0.25	0.18 (0.08)

Technical Data

Impact velocity range: 0.5 to 12 ft/sec (0.15 to 3.66 m/sec)

Mechanical stop: integral mechanical stop built into front of units

Oil type: H1 food grade oil, USDA, FDA & NSF approved

Materials: steel body with Weartec Plus finish. Stainless steel piston rod.

Effective weight: not selectable

Application: Sidel Universal small molds

Sidel Series 1 Machines

Stretch Rod Used without a shock holder	Stretch Rod Used with a unit's shock holder	Mold All Applications	Mold Exception
--	--	--------------------------	-------------------

SCP 650ML-1-FG-NB

SCP 650ML-1-FG-ERSB

SCP 650ML-3-FG-NB
Used as a snubber.

Except the few SBO-40 machines

Note: all models listed are a common interchange selection. The effective weight stiffness can be changed to accommodate customer preference or application requirements.



SCP 650ML-1-FG-NB or SCP 650ML-3-FG-NB



SCP 650ML-1-FG-ERSB

Sidel Series 2 Machines

9

Stretch Rod Down QCM Assembly	Stretch Rod Down Select a model for your specific shock holder	Stretch Rod Up Heat Set Machines	Mold All Machines
----------------------------------	---	-------------------------------------	----------------------

SCP 650ML-1-FG-QCM-880
Quick Change Mount.

This model eliminates the confusion and potential application problems.

SCP 650ML-1-FG-ERSB
Used with shock holder #1073679102 (gold)

SCP 650ML-1-FG-880
Used with shock holder #1131136901 (silver)

SCP 650ML-3-FG-NB
Used as a snubber.

Some customers may prefer to use a "-4" effective weight

SCP 650ML-3-FG-NB
Used as a snubber.

Some customers may prefer to use a "-2" effective weight

Note: all models listed are a common interchange selection. The effective weight stiffness can be changed to accommodate customer preference or application requirements.



SCP 650ML-3-FG-NB



SCP 650ML-1-FG-ERSB



SCP 650ML-1-FG-QCM-880



SCP 650ML-1-FG-880

Sidel Universal Machines

Stretch Rod Used without a shock holder	Stretch Rod Used with a unit's shock holder	Stretch Rod Up Large M27x3 thread	Mold Small M14x1 thread
---	---	---	-----------------------------------

SCP 650ML-1-FG-NB
Not used on all machines.

SCP 650ML-1-FG-880

SCP 650ML-3-FG-NB
Used as a snubber.

SCP 190ME3-439
Used as a snubber.

Some customers may prefer to use a "-2" effective weight

Note: All models listed are a common interchange selection. The effective weight stiffness can be changed to accommodate customer preference or application requirements.



SCP 650ML-1-FG-NB or SCP 650ML-3-FG-NB



SCP 650ML-1-FG-880



SCP 190ME3-439

KRONES Machines

Stretch Rod Used without a shock holder	Mold Large M20x1.5 thread	Mold Small M14x1.5 thread
---	-------------------------------------	-------------------------------------

SCP 650ML-1-FG-SBUC

SCP 300M3-B-FG

To be determind

Note: All models listed are a common interchange selection. The effective weight stiffness can be changed to accommodate customer preference or application requirements.



SCP 650ML-1-FG-SBUC



SCP 300M3-B-FG

ACE

PET Shock Absorbers

Increased production

Increased system performance

Reduced downtime

Reduced reaction forces

Reduced component wear



⚠ WARNING

IMPROPER SELECTION OR IMPROPER USE OF THE PRODUCTS AND/OR SYSTEMS DESCRIBED HEREIN OR RELATED ITEMS CAN CAUSE PERSONAL OR FATAL INJURY AND/OR PROPERTY DAMAGE.

Sidel® is a registered trademark of Sidel® Company.
KRONES® is a registered trademark of KRONES® Company.