



Linear and Motion Solutions

New product line

C-Line Linear guide system



CL 1001 E

C-Line

System LS

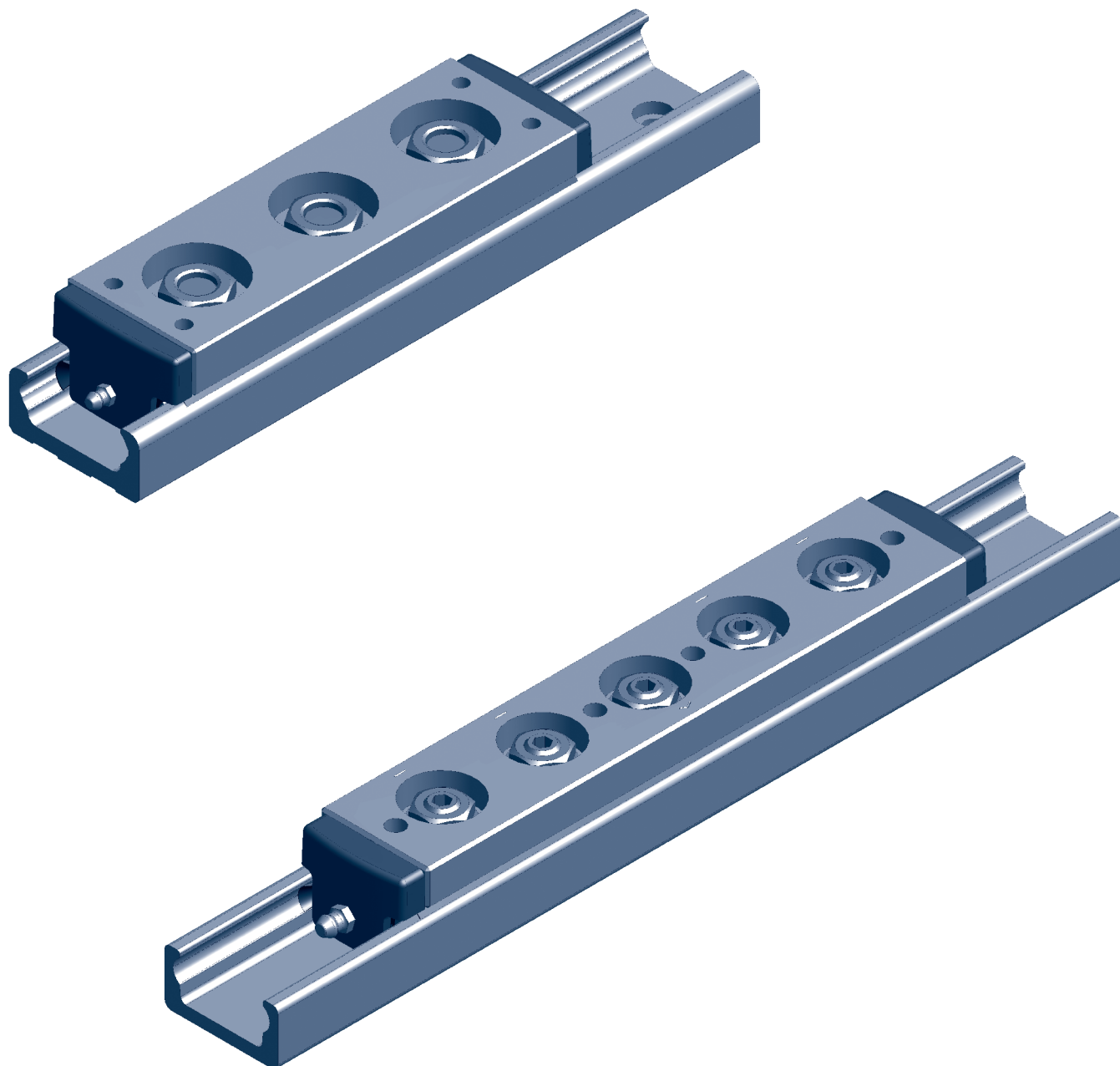

- Compensation of tolerances for parallelism and mounting surfaces
- Guide rollers with fixed and floating bearings
- Easy and permanent running performance
- High speed up to 8 m/s
- Integrated lubricating system

C-Line

System LS

To be in a position to offer complete guide systems the C-Line consists of guide rails, guide rollers and carriages. Guide rails and rollers can be used as individual components; in most cases however, standard carriages are used.

The cold drawn rails have a C shape and are induction hardened. The rollers run on the inside raceways of the C-profile. The rails are zinc-plated; alternatively they are available with nickel-plated surface.

Based on the different design of the rollers, constructions with fixed or floating bearings can be realised. Thereby errors in parallelism, height and angle can be balanced. Only one rail shape is necessary for this.

Nadella offers 3 rail sizes.

The carriages can be adjusted free of play. They are equipped with concentric and eccentric rollers and can be combined with 3, 4 or 5 rollers.

Essential technical properties:

- steel rail, drawn, induction hardened
- zinc-plated rail, alternatively with nickel-plated surface
- rollers for fixed and floating bearing constructions
- high balance of mounting surface errors and misalignment
- high performance and rugged
- rollers lubricated for life
- dust resistant
- easy fitting
- easy smooth running
- high speeds up to 8 m/s (depending on roller size and application)
- acceleration up to 50 m/s²
- working temperatures up to 80°C possible
- pitch of rail borings standard or according to customer drawings
- integrated lubricating system at the front sides of the carriage

The following figure applies to the loads indicated in the tables below:

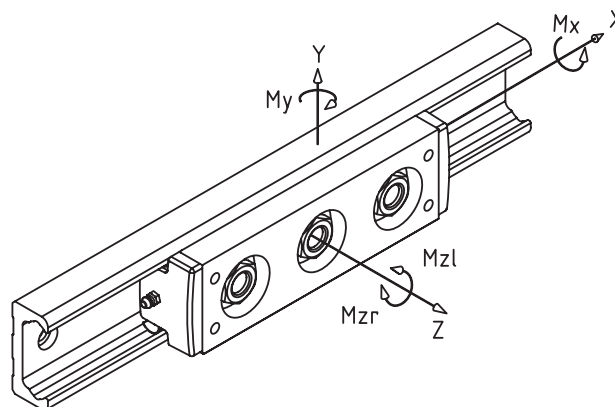

MAX LOAD ON INDIVIDUAL CARRIAGES

The tables below show the maximum load that can be applied to an individual carriage.

Short carriage

Guide	Carriage	Fy N	Fz N	Mx Nm	My Nm	Mz Nm	
						Mzl	Mzr
LS 28	C3 RCS28 126	2400	660	5.9	17	30	30
LS 43	C3 RCS43 170	6000	1700	23	66	117	117
LS 63	C3 RCS63 226	13000	4400	81	264	390	390

Fy with effect on the concentric rollers.

Long carriage

Guide	Carriage	Fy N	Fz N	Mx Nm	My Nm	Mz Nm	
						Mzl	Mzr
LS 28	C3 RCS28 178 A	2400	660	5.9	34	62	62
	C4 RCS28 178 C	2400	1320	12	43	94	94
	C4 RCS28 178 A	1800	990	8.9	38	125	62
	C4 RCS28 178 B	1800	990	8.9	38	62	125
	C5 RCS28 178 A	3000	1320	12	43	94	94
	C5 RCS28 178 B	3600	660	5.9	35	62	62
LS 43	C3 RCS43 245 A	6000	1700	23	129	228	228
	C4 RCS43 245 C	6000	3400	45	162	342	342
	C4 RCS43 245 A	4500	2380	34	129	456	228
	C4 RCS43 245 B	4500	2380	34	129	228	456
	C5 RCS43 245 A	7500	3400	45	162	342	342
	C5 RCS43 245 B	9000	1700	23	133	228	228

Fy with effect on the concentric rollers.

The max load is based on the guide roller values (load capacity of bolt and bearing) and on the max contact pressure of 1250N/mm² between rail and roller. Loads are rated for effect in direction Y exclusively or in direction Z exclusively. A combination of rates reduces the values.

C-Line

System LS

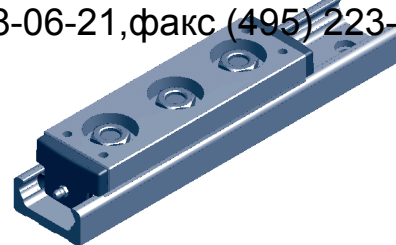

DYNAMIC LOAD CAPACITY OF THE INDIVIDUAL CARRIAGE

The following tables indicate the nominal load which corresponds to a nominal bearing lifetime of 100 km.

$$L_{10} = (C_i/P_i)^3 \times 100 \text{ km}$$

C_i and P_i are the load capacity and the applied load for a certain load direction.

Short carriage

Guide	Carriage	C _y N	C _z N	CM _x Nm	CM _y Nm	CM _z Nm	
						M _{z1}	M _{zr}
LS 28	C3 RCS28 126	4400	1100	9.6	27	55	55
LS 43	C3 RCS43 170	13200	3600	48	142	257	257
LS 63	C3 RCS63 226	28400	6700	124	403	852	852

C_y with effect on the concentric rollers.

Long carriage

Guide	Carriage	C _y N	C _z N	CM _x Nm	CM _y Nm	CM _z Nm	
						M _{z1}	M _{zr}
LS 28	C3 RCS28 178 A	4400	1100	9.6	55	114	114
	C4 RCS28 178 C	4400	2100	19	69	172	172
	C4 RCS28 178 A	3300	1600	14	61	229	114
	C4 RCS28 178 B	3300	1600	14	61	114	229
	C5 RCS28 178 A	6600	2100	19	69	172	172
C5 RCS28 178 B	8800	1100	9.6	67	114	114	
LS 43	C3 RCS43 245 A	13200	3600	48	277	502	502
	C4 RCS43 245 C	13200	7300	96	346	752	752
	C4 RCS43 245 A	9900	5100	72	304	1003	502
	C4 RCS43 245 B	9900	5100	72	304	502	1003
	C5 RCS43 245 A	19800	7300	96	346	752	752
C5 RCS43 245 B	26400	3600	48	292	502	502	

C_y with effect on the concentric rollers.

CARRIAGE CONFIGURATIONS

In the following carriage configurations the dashed guide rollers are concentric.

Short carriage with 3 rollers

Typ C3...

view from above

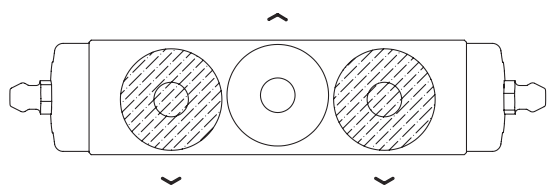

Long carriage with 3 rollers

Type C3...A

view from above

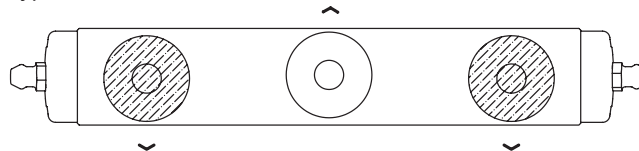

Long carriage with 4 rollers

Type C4...C

view from above

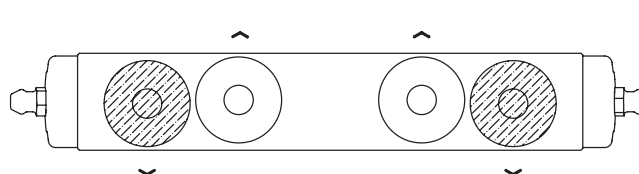

Type C4...A

view from above

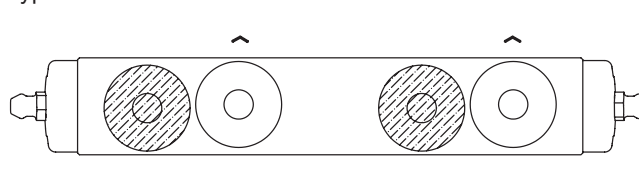

Type C4...B

view from above

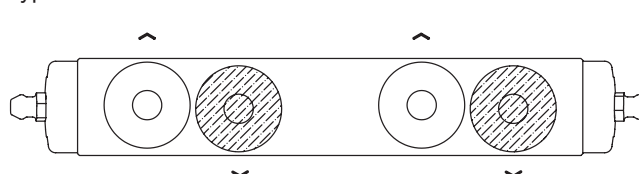

Long carriage with 5 rollers

Type C5...A

view from above

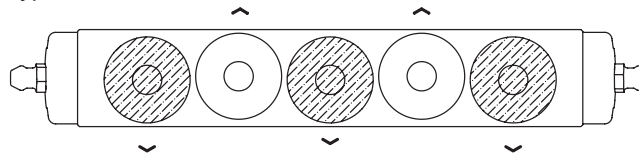

Type C5...B

view from above

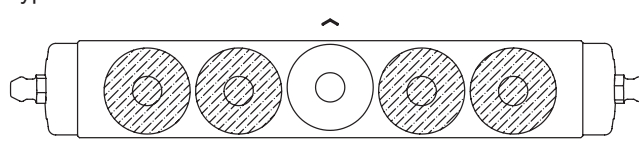

The markings ^ and v show the contact points with the running surface of the rails.

C-Line

System LS

Calculation example:

platform with 4 carriages C3 RCS 43 170 N

The general arrangement is shown in the drawing below.

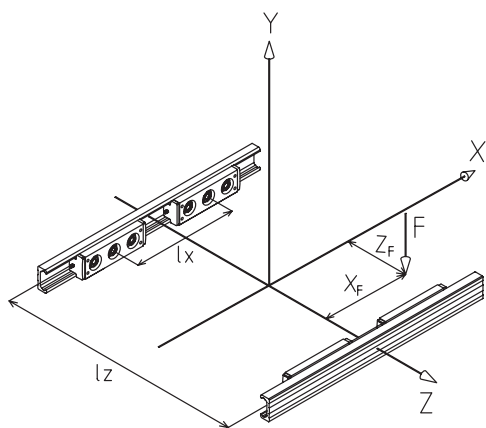

The platform runs along the two rails and is charged with load F which takes effect 100 mm and 50 mm afar from the middle of the carriage.

Data: guide LS 43; carriage C3 RCS 43 170

$l_x = 400 \text{ mm}, \quad l_z = 300 \text{ mm}$
 $F = 6000 \text{ N}, \quad X_F = 100 \text{ mm}, \quad Z_F = 50 \text{ mm}$

In this configuration P_y is the load on the mostly loaded carriage and is calculated as follows:

$$P = \frac{F}{4} + \frac{F \cdot X_F}{2 \cdot l_x} + \frac{F \cdot Z_F}{2 \cdot l_z} = 2750 \text{ N}$$

The load F_y indicated in the table of max load for carriage C3 RCS 43 170 is 6000 N.

The system nominal lifetime is calculated as follows: from the table of the dynamic load capacity, the value C_y for carriage C3 RCS 43 170 is 13200 N.

$$L_{10} = (13.200/2.750)^3 \times 100 = 11.059 \text{ km}$$

Important remark: The rail must be lubricated to reach this value. Otherwise the expected lifetime can be reduced by fretting between rail and roller.

Auto-aligning systems

Self-aligning systems are used to balance high mounting surface tolerances between two parallel installed guides. The Nadella system LS can be combined with the rollers RCS and RAS so that high horizontal or vertical tolerances can be balanced.

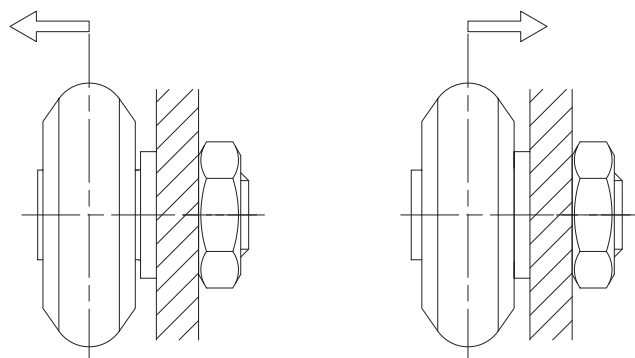

Horizontal adjustment Dx

Fixed bearing:

Carriages equipped with rollers type RCS/RCSR to compensate radial and axial loads.

Floating bearing:

Carriages equipped with rollers type RAS/RASR to compensate radial loads only.

Max. possible value: **Dx = 1,5 mm**

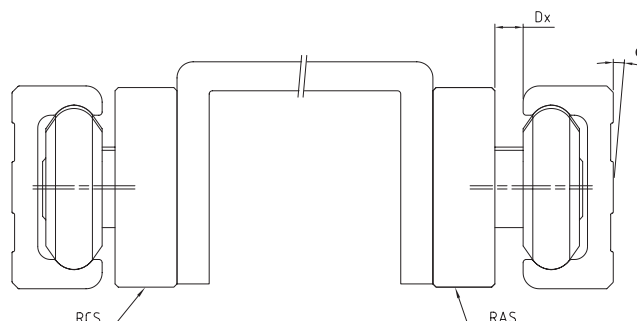

C-Line

System LS

Vertical adjustment D_y

Fixed bearing:

Carriages equipped with concentric rollers type RCS and eccentric rollers type RASR to compensate radial and axial loads. This allows for a tilting movement of the carriage up to the max. tilting angle.

Floating bearing:

Carriages equipped with concentric rollers type RAS and eccentric rollers type RASR to compensate axial loads only.

The value D_y depends on the distance between the rails and the max. possible tilting angle $\alpha = \pm 1.5^\circ$ of the carriage at the fixed bearing side.

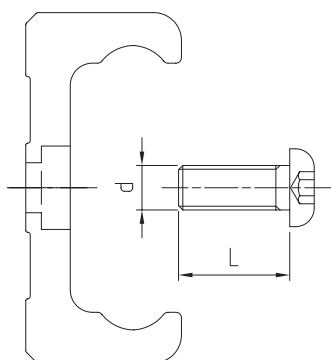
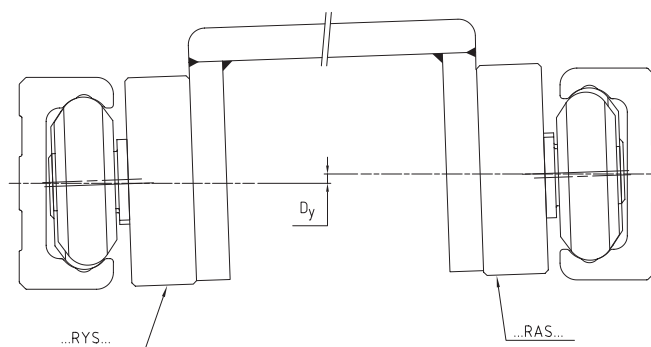

Screw type DIN EN ISO 7380 (10.9)

Max inclined movement admissible for self-aligning tables and carriages

Carriage	α_{ax} (°)	S max (mm)	H nominal (mm)	Guide
C3 RAS28 ... C4 RAS28 ... C5 RAS28 ...	1°	±0.25	24	LS 28
C3 RAS43 ... C4 RAS43 ... C5 RAS43 ...	1.5°	±0.75	37	LS 43
C3 RAS63 ...	1°	±0.75	50.5	LS 63
C3 RYS28 ... C4 RYS28 ... C5 RYS28 ...	1°	---	24	LS 28
C3 RYS43 ... C4 RYS43 ... C5 RYS43 ...	1.5°	---	37	LS 43
C3 RYS63 ...	1°	---	50.5	LS 63

Carriages type ...RAS... only consist of guide rollers type RAS (concentric) and RASR (eccentric).

Carriages type ...RYS... only consist of guide rollers type RCS (concentric) and RASR (eccentric).

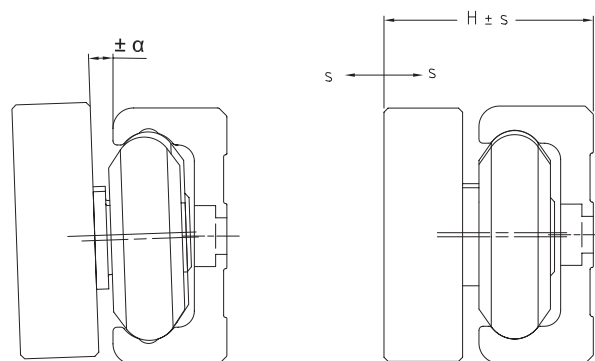

Guide	Screw size d	L	Torque wrench settings (Nm)
LS 28	M5 x 0.8	12	8
LS 43	M8 x 1.25	16	22
LS 63	M8 x 1.25	20	34

C-Line

Guide Rails LS

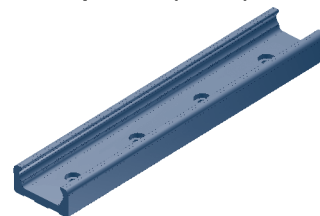

Hole pattern A: boring for counterbore screws according DIN EN ISO 7380

LS 28
LS 43

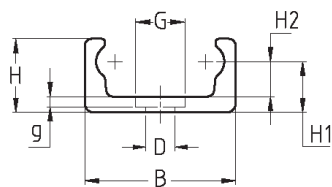

LS 63

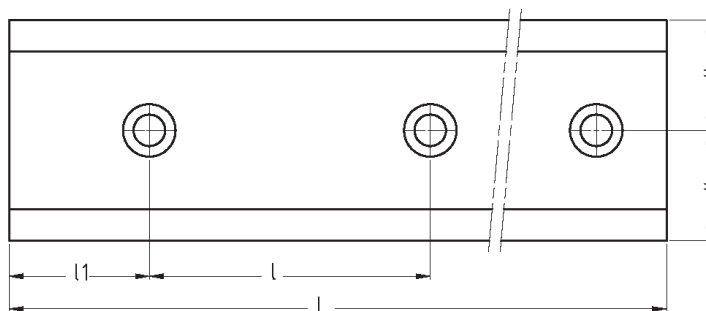
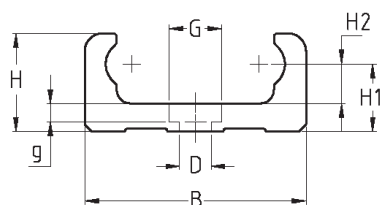

Hole pattern B: boring for countersunk screws according DIN EN ISO 74

LS 28
LS 43

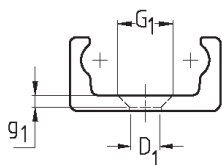

LS 63

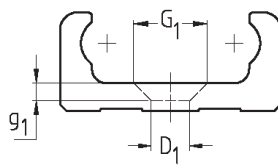

Type	Dimensions (mm)												Moment of inertia (cm ⁴)		Weight (kg/m)	L ⁽¹⁾ max (mm)
	B	H	H ₁	H ₂	D	G	g	D ₁	G ₁	g ₁	l	l ₁	J _x	J _y		
LS 28	28	12.5	9	5.5	6.6	11	2.1	5.5	10.6	2.6	80	40	0.17	1.45	1.18	2960
LS 43	43	21	14.5	10	9	15	2.5	9	17	4	80	40	1.28	8.6	2.75	2960
LS 63	63	28	19.25	11.25	9	15	4.5	11	21	5.5	80	40	4.5	38.9	6.22	2960

1) Longer rails will be fitted with finish-machined joints.

Rail design standard

- drawn, induction hardened raceways **(MT)**
- surface zinc-plated **(GZ)**

Surface options

- chemically nickel-plated **(NW)**
- uncoated blasted **(no suffix) ***

Fixing holes

- hole pattern according to catalogue **(A or B*)**
- hole pattern according to drawing **(NZ) ***
- without holes **(NF) ***

*) available as of 3rd quarter 2012

Example standard type: **LS43MT2480AGZ**

Screws DIN EN ISO 7380 (10.9) are included in delivery.

C-Line

Guide Rollers RCS

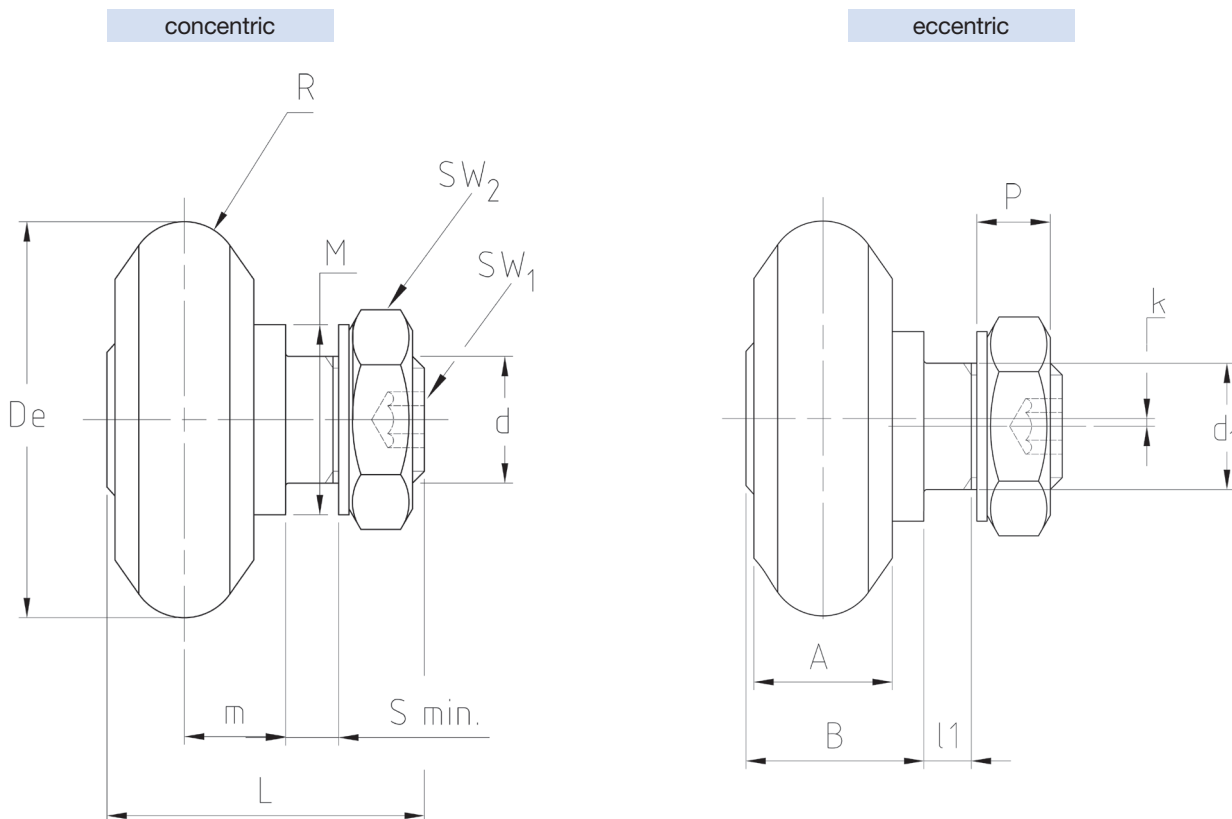

Type		Dimensions (mm)														Guide	
concentric	eccentric	De	R	d ₁ ⁽¹⁾	d	m	S _{min.}	P	L	A	B	l ₁	M	SW ₁	SW ₂		k
RCS 28	RCSR 28	23.5	3	8	M8	6.0	2.5	4.8	18.5	6.0	10.0	3.5	12.0	3	13	0.5	LS 28
RCS 43	RCSR 43	35.5	5	10	M10 x 1.25	9.0	4.5	6.0	27.5	11.0	15.0	5.5	17.5	4	16	0.75	LS 43
RCS 63	RCSR 63	50	7	16	M16 x 1.5	12.75	5.5	9.3	40.0	17.5	22.5	6.5	24.0	6	24	1.0	LS 63

Type		Dynamic loads (N)	Limit loads (N)		Life coefficients		Torque-wrench settings (Nm) ²⁾	Weight (g)
concentric	eccentric	Cw ⁽³⁾	radial F _r	axial F _a	X	Y		
RCS 28	RCSR 28	2200	1200	330	1	2.7	8	25
RCS 43	RCSR 43	6600	3000	850	1	2.2	20	80
RCS 63	RCSR 63	14200	6500	2200	1	2.8	64	255

1) Tolerance of mounting hole: H7

2) The tightening torques apply to non-lubricated threads; for lubricated threads the values have to be multiplied by 0.8.

3) Cw = load for lifetime of 100 km

Guide rollers will be supplied with washers and nuts (DIN 439B).

Contact angle α for the load calculation: 55°

Standard seals type RS

For further information of lifetime calculation please see our general catalogue NL 1001 E.

C-Line

Guide Rollers RAS

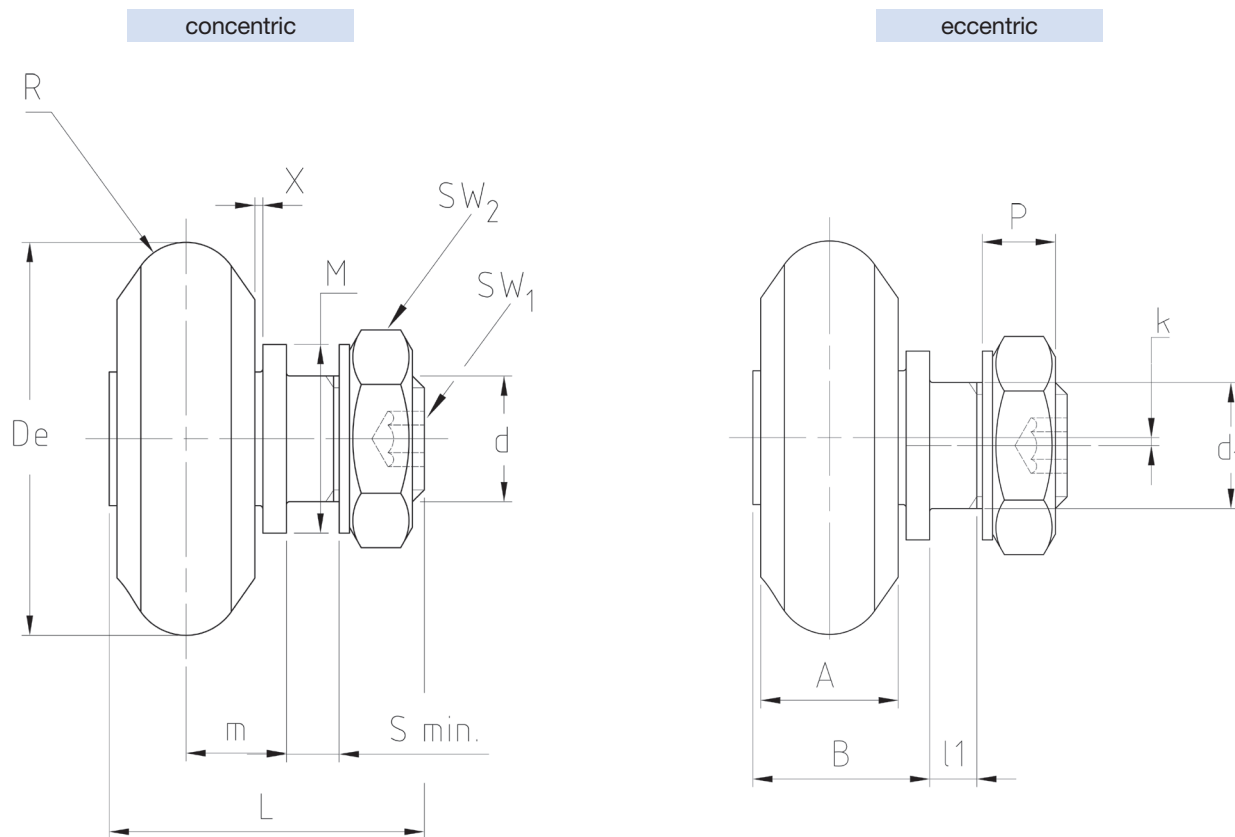

Type		Dimensions (mm)															Guide	
concentric	eccentric	De	R	d ₁ ⁽¹⁾	d	± X ⁽⁴⁾	m	S _{min.}	P	L	A	B	l ₁	M	SW ₁	SW ₂		k
RAS 28	RASR 28	23.5	3	8	M8	0.25	6.0	2.5	4.8	18.5	7.0	10.0	3.5	12.0	3	13	0.5	LS 28
RAS 43	RASR 43	35.5	5	10	M10 x 1.25	0.75	9.0	4.5	6.0	27.5	11.0	15.0	5.5	17.5	4	16	0.75	LS 43
RAS 63	RASR 63	50	7	16	M16 x 1.5	0.75	12.75	5.5	9.3	40.0	17.5	22.5	6.5	24.0	6	24	1.0	LS 43

Type		Dynamic load (N)	Limit load (N)	Torque wrench settings (Nm) ⁽²⁾	Weight (g)
concentric	eccentric	Cw ⁽³⁾	radiale F _r		
RAS 28	RASR 28	2200	1200	8	25
RAS 43	RASR 43	6600	3000	20	80
RAS 63	RASR 63	14200	6500	64	255

1) Tolerance of mounting hole: H7

2) The tightening torques apply to non-lubricated threads; for lubricated threads the values have to be multiplied by 0.8.

3) Cw = load for lifetime of 100 km

4) Maß ± X is the maximum displacement from dimension m to ensure proper guide roller function and safety.

Guide rollers will be supplied with washers and nuts (DIN 439B).

Contact angle α for the load calculation: 55°

Standard seals type RS

For further information of lifetime calculation please see our general catalogue NL 1001 E.



C-Line

Carriages C3 RCS, C3 RAS, C3 RYS

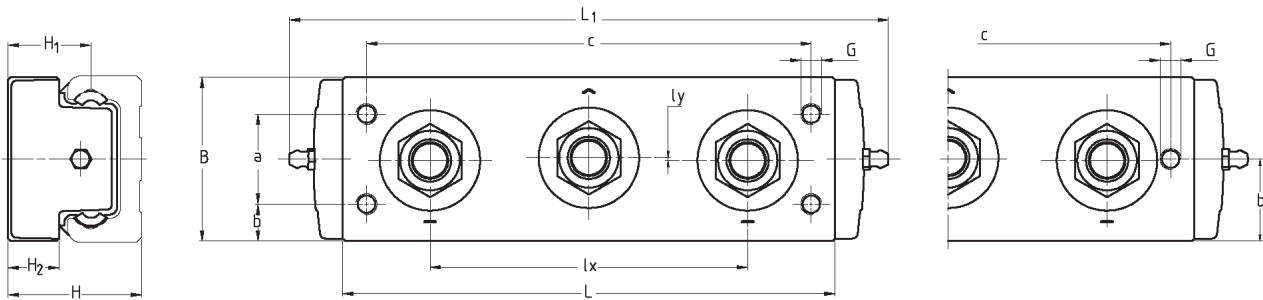
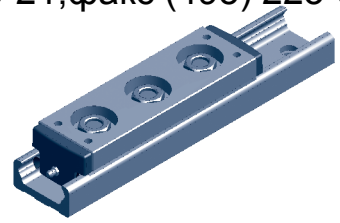

Type	Dimensions (mm)														Weight (kg)	Guide
	L	L ₁	B	l _x	l _y	H	H ₁	H ₂	G	a	b	c	k			
short carriage	C3 RCS28 126	88	126	26.5	50	0.5	24	15	9	M5 (2x)	-	13.25	78	0.75	0.13	LS 28
	C3 RCS43 170	130	170	40	78	1	37	22.5	13.5	M8 (2x)	-	20	114	1	0.44	LS 43
	C3 RCS63 226	186	226	60	120	1	50.5	31.25	18.5	M8 (4x)	34	13	168	1.5	1.20	LS 63

Dimensions also apply to C3 RAS and C3 RYS.

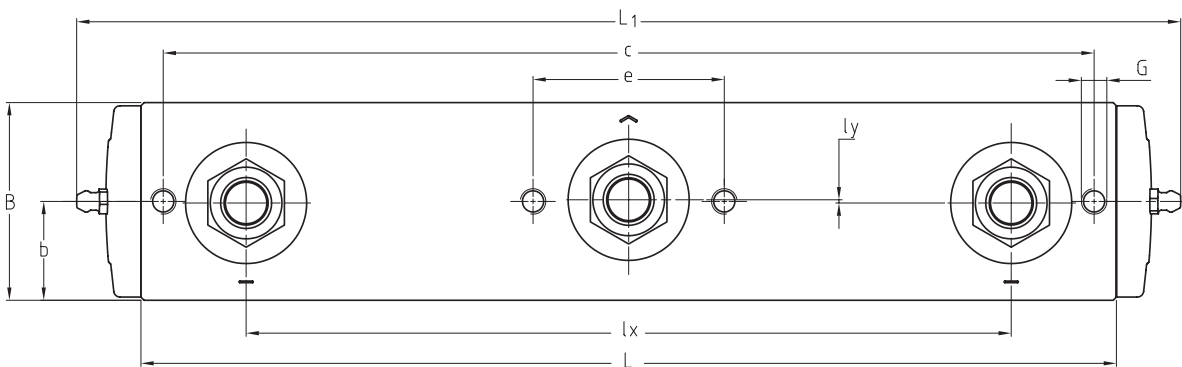

Type	Dimensions (mm)														Weight (kg)	Guide
	L	L ₁	B	l _x	l _y	H	H ₁	H ₂	G	b	c	e	k			
long carriage	C3 RCS28 178 A	140	178	26.5	104	0.5	24	15	9	M5	13.25	130	26	0.75	0.15	LS 28
	C3 RCS43 245 A	205	245	41	152	1	37	22.5	13.5	M8	20.5	188	37	1.5	0.50	LS 43

Dimensions also apply to C3 RAS and C3 RYS.

The markings show the contact points with the running surface of the rails.

C-Line

Carriages C4 RCS, C4 RAS, C4 RYS

Roller combinations

The markings show the contact points with the running surface of the rails.

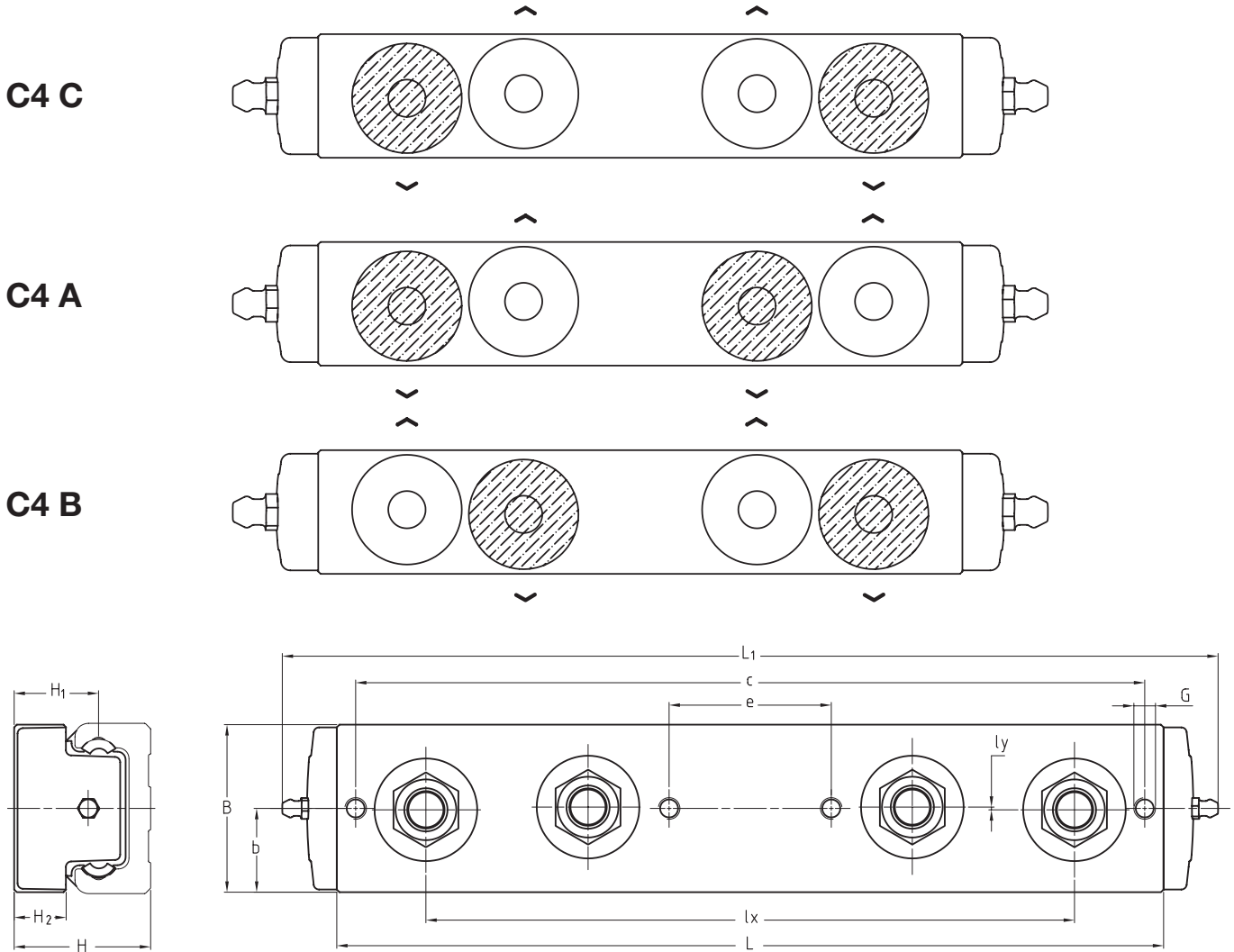

Type	Dimensions (mm)													Weight (kg)	Guide
	L	L ₁	B	l _x	l _y	H	H ₁	H ₂	G	b	c	e	k		
C4 RCS28 178 C C4 RCS28 178 A C4 RCS28 178 B	140	178	26.5	104	0.5	24	15	9	M5	13.25	130	26	0.75	0.23	LS 28
C4 RCS43 245 C C4 RCS43 245 A C4 RCS43 245 B	205	245	41	152	1	37	22.5	13.5	M8	20.5	188	37	1	0.58	LS 43

Dimensions also apply to C4 RAS C/A/B and C4 RYS C/A/B.



C-Line

Carriages C5 RCS, C5 RAS, C5 RYS

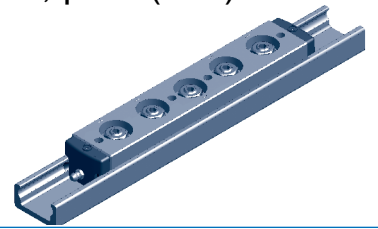

Roller combinations

The markings show the contact points with the running surface of the rails.

C5 A

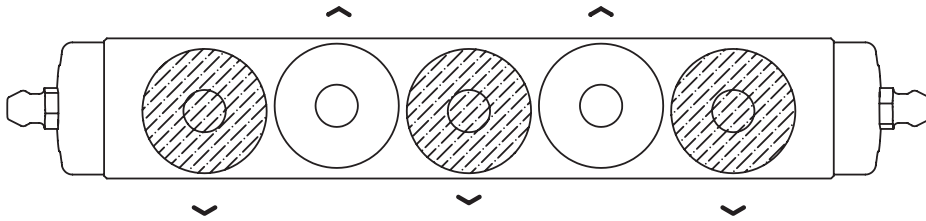

C5 B

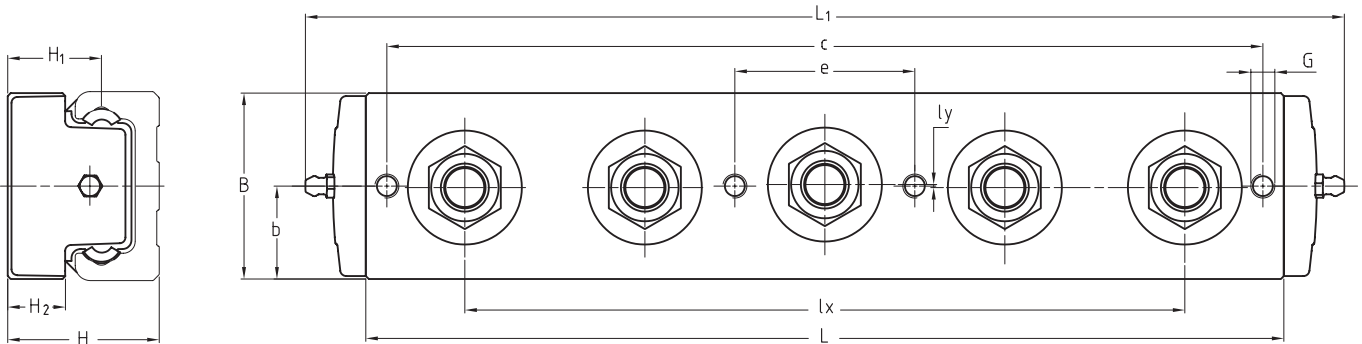
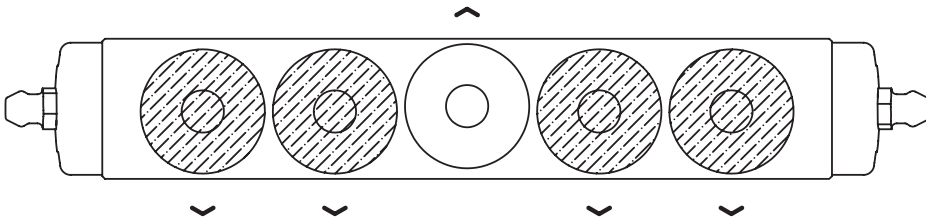

Type	Dimensions (mm)													Weight (kg)	Guide
	L	L ₁	B	l _x	l _y	H	H ₁	H ₂	G	b	c	e	k		
C5 RCS28 178 A C5 RCS28 178 B	140	178	26.5	104	0.5	24	15	9	M5	13.25	130	26	0.75	0.25	LS 28
C5 RCS43 245 A C5 RCS43 245 B	205	245	41	152	1	37	22.5	13.5	M8	20.5	188	37	1	0.66	LS 43

Dimensions also apply to C5 RAS A/B and C5 RYS A/B.

Nadella linear guide systems

Base-Line FWS, FWH, DC, C

- economy model for light and medium charges
- available in stainless steel (DC, C)
- thin type for space-saving desing (DC, C)

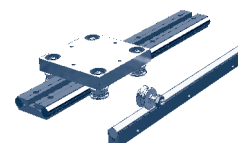

Flexi-Line 645 FWN

- dimensions acc. DIN 645 with flexible configurations
- for light loads and low-noise running
- ready to install
- stainless steel version available

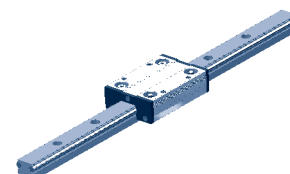

U-Line LM

- for light and medium charges
- carriages in compact U-profile mounted inside
- stainless steel version available

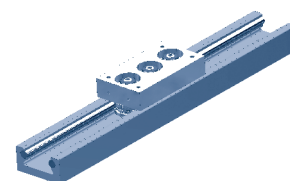

V-Line FS, FSH

- steel rails with V-profile
- for all loads and all applications
- various scopes for design
- corrosion protection with surface treatment possible

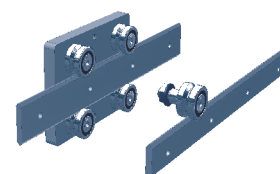

Multi-Motion-Line FSR, FSRV

- multi-motion system based on V-line profiles
- guide rings and curved rails
- rolled vertical guides for outsized radius
- corrosion protection with surface treatment possible

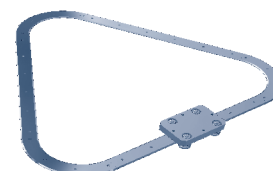

Heavy-Line GU, GP

- for high loads and use in dirty environment
- guide rollers with tapered roller bearings
- guide rails for fixed and floating bearings
- corrosion protection with surface treatment possible

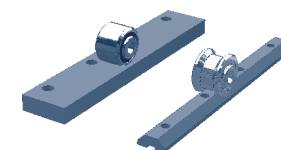

Rolbloc

- for extremely high loads and robust applications
- up to 15 tons per carriage
- high compensation with easy mounting surface

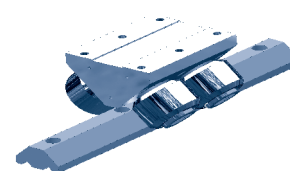

For any further information please order our general catalogue for linear guide systems NL 1001 E or visit www.nadella.eu.

Nadella S.r.l.

Via Melette, 16
20128 Milano
Tel. +39 02.27.093.297
Fax +39 02.25.51.768
Internet: www.nadella.it
E-Mail: customer.service@nadella.it

Nadella GmbH

Rudolf-Diesel-Straße 28
71154 Nufringen
Tel. +49 (0)70 32 95 40-0
Fax +49 (0)70 32 95 40-25
Internet: www.nadella.de
E-Mail: info@nadella.de

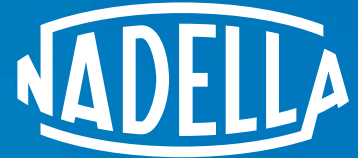

Linear and Motion Solutions

NADELLA WORLDWIDE ORGANISATION

Europe:

- Austria
- Czech Republic
- Denmark
- Finland
- France
- Germany
- Hungary
- Italy
- Netherlands
- Norway
- Poland
- Romania
- Slovakia
- Slovenia
- Spain
- Sweden
- Switzerland
- Turkey



• Branches and distributors

www.nadella.eu

