

4. Bearing Load Calculation

To compute bearing loads, the forces which act on the shaft being supported by the bearing must be determined. Loads which act on the shaft and its related parts include dead load of the rotator, load produced when the machine performs work, and load produced by transmission of dynamic force. These can theoretically be mathematically calculated, but calculation is difficult in many cases.

A method of calculating loads that act upon shafts that convey dynamic force, which is the primary application of bearings, is provided herein.

4.1 Load acting on shafts

4.1.1 Load factor

There are many instances where the actual operational shaft load is much greater than the theoretically calculated load, due to machine vibration and/or shock. This actual shaft load can be found by using formula (4.1).

$$K = f_w \cdot K_c \quad \dots\dots (4.1)$$

where,

K : Actual shaft load N {kgf}

f_w : Load factor (Table 4.1)

K_c : Theoretically calculated value N {kgf}

Table 4.1 Load factor f_w

Amount of shock	f_w	Application
Very little or no shock	1.0~1.2	Electric machines, machine tools, measuring instruments.
Light shock	1.2~1.5	Railway vehicles, automobiles, rolling mills, metal working machines, paper making machines, printing machines, aircraft, textile machines, electrical units, office machines.
Heavy shock	1.5~3.0	Crushers, agricultural equipment, construction equipment, cranes.

4.1.2 Gear load

The loads operating on gears can be divided into three main types according to the direction in which the load is applied; i.e. tangential (K_t), radial (K_s), and axial (K_a). The magnitude and direction of these loads differ according to the types of gears involved. The load calculation methods given herein are for two general-use gear and shaft arrangements: parallel shaft gears, and cross shaft gears.

(1) Loads acting on parallel shaft gears

The forces acting on spur gears and helical gears are depicted in Figs. 4.1, 4.2, and 4.3. The load magnitude can be found by using or formulas (4.2), through (4.5).

$$\left. \begin{aligned} K_t &= \frac{19.1 \times 10^6 \cdot H}{D_p \cdot n} \quad \text{N} \\ &= \frac{1.95 \times 10^6 \cdot H}{D_p \cdot n} \quad \text{kgf} \end{aligned} \right\} \dots\dots (4.2)$$

$$K_s = K_t \cdot \tan \alpha \quad (\text{Spur gear}) \quad \dots\dots (4.3a)$$

$$= K_t \cdot \frac{\tan \alpha}{\cos \beta} \quad (\text{Helical gear}) \quad \dots\dots (4.3b)$$

$$K_r = \sqrt{K_t^2 + K_s^2} \quad \dots\dots (4.4)$$

$$K_a = K_t \cdot \tan \beta \quad (\text{Helical gear}) \quad \dots\dots (4.5)$$

where,

K_t : Tangential gear load (tangential force), N {kgf}

K_s : Radial gear load (separating force), N {kgf}

K_r : Right angle shaft load (resultant force of tangential force and separating force), N {kgf}

K_a : Parallel load on shaft, N {kgf}

H : Transmission force, kW

n : Rotational speed, min^{-1}

D_p : Gear pitch circle diameter, mm

α : Gear pressure angle, deg

β : Gear helix angle, deg

Because the actual gear load also contains vibrations and shock loads as well, the theoretical load obtained by the above formula should also be adjusted by the gear factor f_z as shown in Table 4.2.

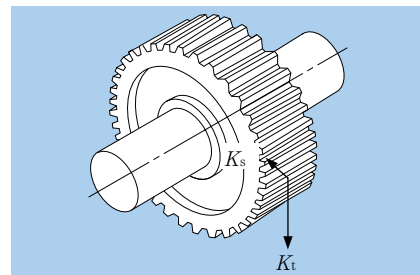

Fig. 4.1 Spur gear loads

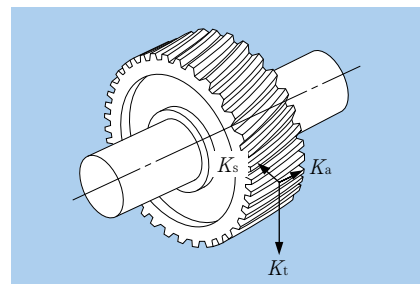

Fig. 4.2 Helical gear loads

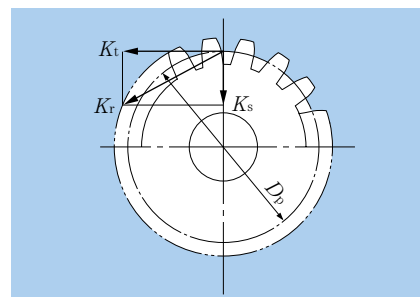

Fig. 4.3 Radial resultant forces

Table 4.2 Gear factor f_z

Gear type	f_z
Precision ground gears (Pitch and tooth profile errors of less than 0.02 mm)	1.05~1.1
Ordinary machined gears (Pitch and tooth profile errors of less than 0.1 mm)	1.1~1.3

(2) Loads acting on cross shafts

Gear loads acting on straight tooth bevel gears and spiral bevel gears on cross shafts are shown in **Figs. 4.4** and **4.5**. The calculation methods for these gear loads are shown in **Table 4.3**. Herein, to calculate gear loads for straight bevel gears, the helix angle $\beta = 0$.

The symbols and units used in **Table 4.3** are as follows:

- K_t : Tangential gear load (tangential force), N {kgf}
- K_s : Radial gear load (separating force), N {kgf}
- K_a : Parallel shaft load (axial load), N {kgf}
- H : Transmission force, kW
- n : Rotational speed, min^{-1}
- D_{pm} : Mean pitch circle diameter, mm
- α : Gear pressure angle, deg
- β : Helix angle, deg
- δ : Pitch cone angle, deg

Because the two shafts intersect, the relationship of pinion and gear load is as follows:

$$K_{sp} = K_{ag} \dots \dots \dots (4.6)$$

$$K_{ap} = K_{sg} \dots \dots \dots (4.7)$$

where,

- K_{sp}, K_{sg} : Pinion and gear separating force, N {kgf}
- K_{ap}, K_{ag} : Pinion and gear axial load, N {kgf}

For spiral bevel gears, the direction of the load varies depending on the direction of the helix angle, the direction of rotation, and which side is the driving side or the driven side. The directions for the separating force (K_s) and axial load (K_a) shown in **Fig. 4.5** are positive directions. The direction of rotation and the helix angle direction are defined as viewed from the large end of the gear. The gear rotation direction in **Fig. 4.5** is assumed to be clockwise (right).

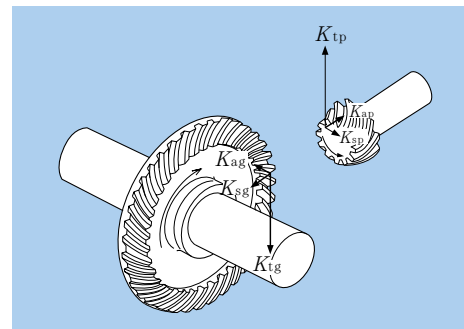

Fig. 4.4 Loads on bevel gears

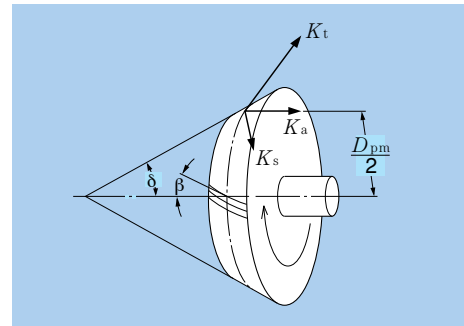

Fig. 4.5 Bevel gear diagram

Table 4.3 Loads acting on bevel gears

Types of load	Rotation direction	Clockwise	Counter clockwise	Clockwise	Counter clockwise
	Helix direction	Right	Left	Left	Right
Tangential load (tangential force) K_t	$K_t = \frac{19.1 \times 10^6 \cdot H}{D_{pm} \cdot n}, \left\{ \frac{1.95 \times 10^6 \cdot H}{D_{pm} \cdot n} \right\}$				
Radial load (separation force) K_s	Driving side	$K_s = K_t \left[\tan \alpha \frac{\cos \delta}{\cos \beta} + \tan \beta \sin \delta \right]$	$K_s = K_t \left[\tan \alpha \frac{\cos \delta}{\cos \beta} - \tan \beta \sin \delta \right]$	$K_s = K_t \left[\tan \alpha \frac{\cos \delta}{\cos \beta} - \tan \beta \sin \delta \right]$	$K_s = K_t \left[\tan \alpha \frac{\cos \delta}{\cos \beta} + \tan \beta \sin \delta \right]$
	Driven side	$K_s = K_t \left[\tan \alpha \frac{\cos \delta}{\cos \beta} - \tan \beta \sin \delta \right]$	$K_s = K_t \left[\tan \alpha \frac{\cos \delta}{\cos \beta} + \tan \beta \sin \delta \right]$	$K_s = K_t \left[\tan \alpha \frac{\cos \delta}{\cos \beta} + \tan \beta \sin \delta \right]$	$K_s = K_t \left[\tan \alpha \frac{\cos \delta}{\cos \beta} - \tan \beta \sin \delta \right]$
Parallel load on gear shaft (axial load) K_a	Driving side	$K_a = K_t \left[\tan \alpha \frac{\sin \delta}{\cos \beta} - \tan \beta \cos \delta \right]$	$K_a = K_t \left[\tan \alpha \frac{\sin \delta}{\cos \beta} + \tan \beta \cos \delta \right]$	$K_a = K_t \left[\tan \alpha \frac{\sin \delta}{\cos \beta} + \tan \beta \cos \delta \right]$	$K_a = K_t \left[\tan \alpha \frac{\sin \delta}{\cos \beta} - \tan \beta \cos \delta \right]$
	Driven side	$K_a = K_t \left[\tan \alpha \frac{\sin \delta}{\cos \beta} + \tan \beta \cos \delta \right]$	$K_a = K_t \left[\tan \alpha \frac{\sin \delta}{\cos \beta} - \tan \beta \cos \delta \right]$	$K_a = K_t \left[\tan \alpha \frac{\sin \delta}{\cos \beta} - \tan \beta \cos \delta \right]$	$K_a = K_t \left[\tan \alpha \frac{\sin \delta}{\cos \beta} + \tan \beta \cos \delta \right]$

4.1.3 Chain / belt shaft load

The tangential loads on sprockets or pulleys when power (load) is transmitted by means of chains or belts can be calculated by formula (4.8).

$$K_t = \frac{19.1 \times 10^6 \cdot H}{D_p \cdot n} \quad \text{N} \left. \begin{array}{l} \\ \\ \\ \end{array} \right\} \dots\dots\dots (4.8)$$

$$= \frac{1.95 \times 10^6 \cdot H}{D_p \cdot n} \quad \text{\{kgf\}}$$

where,

- K_t : Sprocket/pulley tangential load, N {kgf}
- H : Transmitted force, kW
- D_p : Sprocket/pulley pitch diameter, mm

For belt drives, an initial tension is applied to give sufficient constant operating tension on the belt and pulley. Taking this tension into account, the radial loads acting on the pulley are expressed by formula (4.9). For chain drives, the same formula can also be used if vibrations and shock loads are taken into consideration.

$$K_r = f_b \cdot K_t \dots (4.9)$$

where,

- K_r : Sprocket or pulley radial load, N {kgf}
- f_b : Chain or belt factor (**Table 4.4**)

Table 4.4 chain or belt factor f_b

Chain or belt type	f_b
Chain (single)	1.2~1.5
V-belt	1.5~2.0
Timing belt	1.1~1.3
Flat belt (w / tension pulley)	2.5~3.0
Flat belt	3.0~4.0

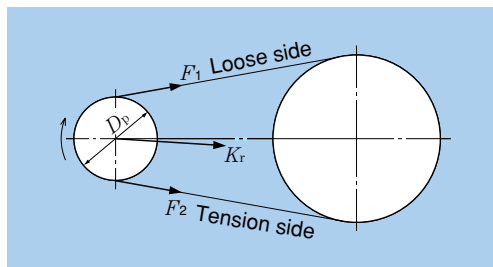

Fig. 4.6 Chain / belt loads

4.2 Bearing load distribution

For shafting, the static tension is considered to be supported by the bearings, and any loads acting on the shafts are distributed to the bearings.

For example, in the gear shaft assembly depicted in **Fig. 4.7**, the applied bearing loads can be found by using formulas (4.10) and (4.11).

This example is a simple case, but in reality, many of the calculations are quite complicated.

$$F_{rA} = \frac{a+b}{b} F_I + \frac{d}{c+d} F_{II} \dots\dots\dots (4.10)$$

$$F_{rB} = -\frac{a}{b} F_I + \frac{c}{c+d} F_{II} \dots\dots\dots (4.11)$$

where,

- F_{rA} : Radial load on bearing A, N {kgf}
- F_{rB} : Radial load on bearing B, N {kgf}
- F_I, F_{II} : Radial load on shaft, N {kgf}

If directions of radial load differ, the vector sum of each respective load must be determined.

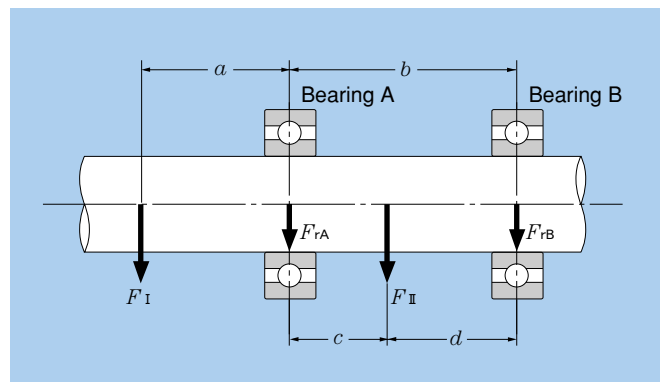

Fig. 4.7

4.3 Mean load

The load on bearings used in machines under normal circumstances will, in many cases, fluctuate according to a fixed time period or planned operation schedule. The load on bearings operating under such conditions can be converted to a mean load (F_m), this is a load which gives bearings the same life they would have under constant operating conditions.

(1) Fluctuating stepped load

The mean bearing load, F_m , for stepped loads is calculated from formula (4.12). F_1, F_2, \dots, F_n are the loads acting on the bearing; n_1, n_2, \dots, n_n and t_1, t_2, \dots, t_n are the bearing speeds and operating times respectively.

$$F_m = \left[\frac{\sum (F_i^p n_i t_i)}{\sum (n_i t_i)} \right]^{1/p} \dots \dots \dots (4.12)$$

where:

- $p=3$ For ball bearings
- $p=10/3$ For roller bearings

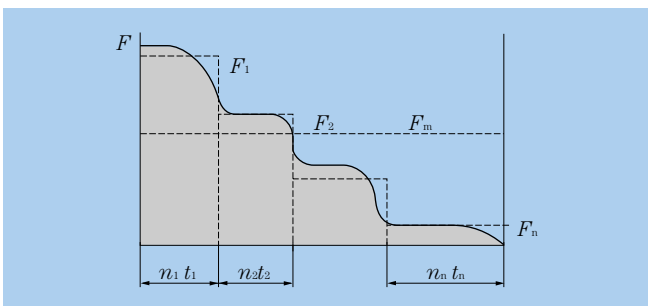

Fig. 4.8 Stepped load

(2) Continuously fluctuating load

Where it is possible to express the function $F(t)$ in terms of load cycle t_o and time t , the mean load is found by using formula (4.13).

$$F_m = \left[\frac{1}{t_o} \int_0^{t_o} F(t)^p dt \right]^{1/p} \dots \dots \dots (4.13)$$

where:

- $p=3$ For ball bearings
- $p=10/3$ For roller bearings

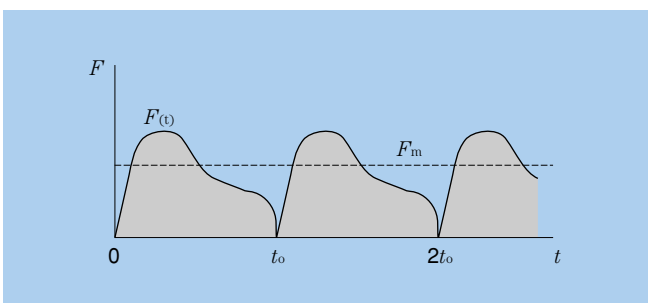

Fig. 4.9 Load that fluctuated as function of time

(3) Linear fluctuating load

The mean load, F_m , can be approximated by formula (4.14).

$$F_m = \frac{F_{min} + 2F_{max}}{3} \dots (4.14)$$

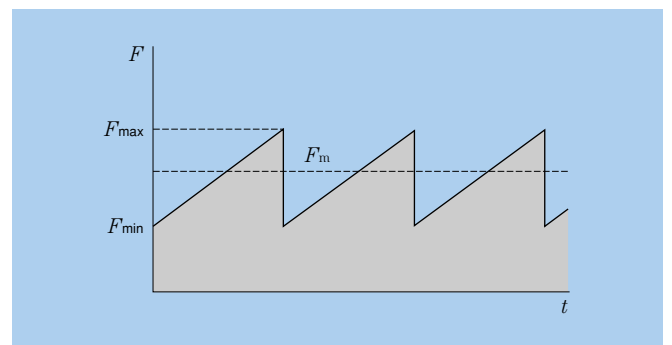

Fig. 4.10 Linear fluctuating load

(4) Sinusoidal fluctuating load

The mean load, F_m , can be approximated by formulas (4.15) and (4.16).

case (a) $F_m = 0.75 F_{max} \dots \dots \dots (4.15)$

case (b) $F_m = 0.65 F_{max} \dots \dots \dots (4.16)$

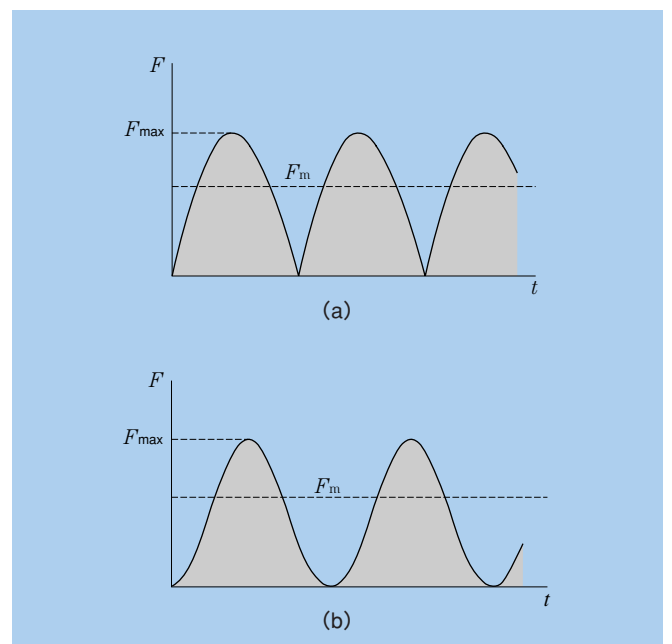

Fig. 4.11 Sinusoidal variable load

4.4 Equivalent load

4.4.1 Dynamic equivalent load

When both dynamic radial loads and dynamic axial loads act on a bearing at the same time, the hypothetical load acting on the center of the bearing which gives the bearings the same life as if they had only a radial load or only an axial load is called the dynamic equivalent load.

For radial bearings, this load is expressed as pure radial load and is called the dynamic equivalent radial load. For thrust bearings, it is expressed as pure axial load, and is called the dynamic equivalent axial load.

(1) Dynamic equivalent radial load

The dynamic equivalent radial load is expressed by formula (4.17).

$$P_r = XF_r + YF_a \dots \dots \dots (4.17)$$

where,

- P_r : Dynamic equivalent radial load, N {kgf}
- F_r : Actual radial load, N {kgf}
- F_a : Actual axial load, N {kgf}
- X : Radial load factor
- Y : Axial load factor

The values for X and Y are listed in the bearing tables.

(2) Dynamic equivalent axial load

As a rule, standard thrust bearings with a contact angle of 90° cannot carry radial loads. However, self-aligning thrust roller bearings can accept some radial load. The dynamic equivalent axial load for these bearings is given in formula (4.18).

$$P_a = F_a + 1.2F_r \dots \dots \dots (4.18)$$

where,

- P_a : Dynamic equivalent axial load, N {kgf}
- F_a : Actual axial load, N {kgf}
- F_r : Actual radial load, N {kgf}

Provided that $F_r / F_a \leq 0.55$ only.

4.4.2 Static equivalent load

The static equivalent load is a hypothetical load which would cause the same total permanent deformation at the most heavily stressed contact point between the rolling elements and the raceway as under actual load conditions; that is when both static radial loads and static axial loads are simultaneously applied to the bearing.

For radial bearings this hypothetical load refers to pure radial loads, and for thrust bearings it refers to pure centric axial loads. These loads are designated static equivalent radial loads and static equivalent axial loads respectively.

(1) Static equivalent radial load

For radial bearings the static equivalent radial load can be found by using formula (4.19) or (4.20). The greater of the two resultant values is always taken for P_{or} .

$$P_{or} = X_o F_r + Y_o F_a \dots \dots \dots (4.19)$$

$$P_{or} = F_r \dots \dots \dots (4.20)$$

where,

- P_{or} : Static equivalent radial load, N {kgf}
- F_r : Actual radial load, N {kgf}
- F_a : Actual axial load, N {kgf}
- X_o : Static radial load factor
- Y_o : Static axial load factor

The values for X_o and Y_o are given in the respective bearing tables.

(2) Static equivalent axial load

For spherical thrust roller bearings the static equivalent axial load is expressed by formula (4.21).

$$P_{oa} = F_a + 2.7F_r \dots \dots \dots (4.21)$$

where,

- P_{oa} : Static equivalent axial load, N {kgf}
- F_a : Actual axial load, N {kgf}
- F_r : Actual radial load, N {kgf}

Provided that $F_r / F_a \leq 0.55$ only.

4.4.3 Load calculation for angular contact ball bearings and tapered roller bearings

For angular contact ball bearings and tapered roller bearings the pressure cone apex (load center) is located as shown in Fig. 4.12, and their values are listed in the bearing tables.

When radial loads act on these types of bearings the component force is induced in the axial direction. For this reason, these bearings are used in pairs. For load calculation this component force must be taken into consideration and is expressed by formula (4.22).

$$F_a = \frac{0.5F_r}{Y} \dots \dots \dots (4.22)$$

where,

- F_a : Axial component force, N {kgf}
- F_r : Radial load, N {kgf}
- Y : Axial load factor

The dynamic equivalent radial loads for these bearing pairs are given in Table 4.5.

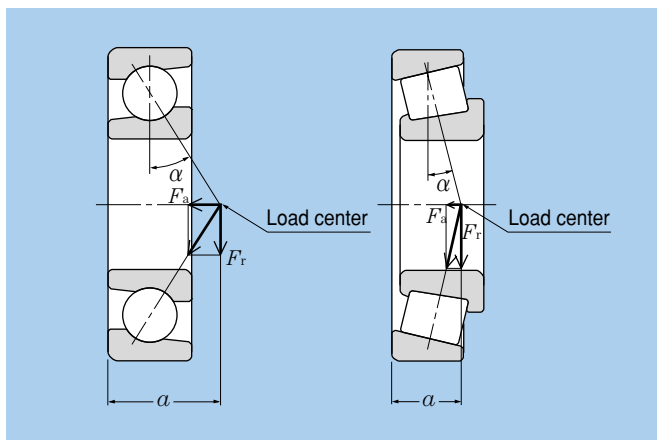

Fig. 4.12 Pressure cone apex and axial component force

Table 4.5 Bearing arrangement and dynamic equivalent load

Bearing arrangement	Load condition	Axial load	Dynamic equivalent radial load
Rear Brg I Brg II 	$\frac{0.5F_{rI}}{Y_I} \leq \frac{0.5F_{rII}}{Y_{II}} + F_a$	$F_{aI} = \frac{0.5F_{rII}}{Y_{II}} + F_a$	$P_{rI} = XF_{rI} + Y_I \left(\frac{0.5F_{rII}}{Y_{II}} + F_a \right)$
		—	$P_{rII} = F_{rII}$
Front Brg II Brg I 	$\frac{0.5F_{rI}}{Y_I} > \frac{0.5F_{rII}}{Y_{II}} + F_a$	—	$P_{rI} = F_{rI}$
		$F_{aII} = \frac{0.5F_{rI}}{Y_I} - F_a$	$P_{rII} = XF_{rII} + Y_{II} \left(\frac{0.5F_{rI}}{Y_I} - F_a \right)$
Rear Brg I Brg II 	$\frac{0.5F_{rII}}{Y_{II}} \leq \frac{0.5F_{rI}}{Y_I} + F_a$	—	$P_{rI} = F_{rI}$
		$F_{aII} = \frac{0.5F_{rI}}{Y_I} + F_a$	$P_{rII} = XF_{rII} + Y_{II} \left(\frac{0.5F_{rI}}{Y_I} + F_a \right)$
Front Brg II Brg I 	$\frac{0.5F_{rII}}{Y_{II}} > \frac{0.5F_{rI}}{Y_I} + F_a$	$F_{aI} = \frac{0.5F_{rII}}{Y_{II}} - F_a$	$P_{rI} = XF_{rI} + Y_I \left(\frac{0.5F_{rII}}{Y_{II}} - F_a \right)$
		—	$P_{rII} = F_{rII}$

Note 1: Applies when preload is zero.

Note 2: Radial forces in the opposite direction to the arrow in the above illustration are also regarded as positive.

4.5 Bearing rating life and load calculation examples

In the examples given in this section, for the purpose of calculation, all hypothetical load factors as well as all calculated load factors may be presumed to be included in the resultant load values.

(Example 1)

What is the rating life in hours of operation (L_{10h}) for deep groove ball bearing **6208** operating at rotational speed $n = 650 \text{ min}^{-1}$, with a radial load F_r of 3.2 kN {326 kgf} ?

From formula (4.17) the dynamic equivalent radial load:

$$P_r = F_r = 3.2 \text{ kN} \{326 \text{ kgf}\}$$

Basic dynamic load rating C_r for bearing 6208 given on page B-12 is 29.1 kN {2970 kgf}, ball bearing speed factor f_n relative to rotational speed $n = 650 \text{ min}^{-1}$ from **Fig. 3.1** is $f_n = 0.37$. Thus life factor f_h from formula (3.5) is:

$$f_h = f_n \frac{C_r}{P_r} = 0.37 \times \frac{29.1}{3.2} = 3.36$$

Therefore, with $f_h = 3.36$ from **Fig. 3.1** the rated life, L_{10h} , is approximately 19,000 hours.

(Example 2)

What is the life rating L_{10h} for the same bearing and conditions as in **Example 1**, but with an additional axial load F_a of 1.8 kN {184 kgf} ?

To find the dynamic equivalent radial load value for P_r , the radial load factor X and axial load factor Y are used. Basic static load rating C_{or} for bearing 6208 given on page B-12 is 17.8 kN {1820 kgf} and f_o is 14.0. Therefore:

$$\frac{f_o \cdot F_a}{C_{or}} = \frac{14 \times 1.8}{17.8} = 1.42$$

Calculating by the proportional interpolation method given on page B-13, $e = 0.30$.

For the operating radial load and axial load:

$$\frac{F_a}{F_r} = \frac{1.8}{3.2} = 0.56 > e = 0.30$$

From page B-13 $X = 0.56$ and $Y = 1.44$, and from formula (4.17) the equivalent radial load, P_r , is:

$$\begin{aligned} P_r &= XF_r + YF_a = 0.56 \times 3.2 + 1.43 \times 1.8 \\ &= 4.38 \text{ kN} \{447 \text{ kgf}\} \end{aligned}$$

From **Fig. 3.1** and formula (3.1) the life factor, f_h , is:

$$f_h = f_n \frac{C_r}{P_r} = 0.37 \times \frac{29.1}{4.38} = 2.46$$

Therefore, with life factor $f_h = 2.46$, from **Fig. 3.1** the rated life, L_{10h} , is approximately 7,500 hours.

(Example 3)

Determine the optimum model number for a cylindrical roller bearing operating at the rotational speed $n = 450 \text{ min}^{-1}$, with a radial load F_r of 200 kN {20,400 kgf}, and which must have a life (L_{10h}) of over 20,000 hours.

From **Fig. 3.1** the life factor $f_h = 3.02$ (L_{10h} at 20,000), and the speed factor $f_n = 0.46$ ($n = 450 \text{ min}^{-1}$). To find the required basic dynamic load rating, C_r , formula (3.1) is used.

$$\begin{aligned} C_r &= \frac{f_h}{f_n} P_r = \frac{3.02}{0.46} \times 200 \\ &= 1,313 \text{ kN} \{134,000 \text{ kgf}\} \end{aligned}$$

From page B-106, the smallest bearing that fulfills all the requirements is **NU2336** ($C_r = 1,380 \text{ kN} \{141,000 \text{ kgf}\}$).

(Example 4)

The spur gear shown in **Fig. 4.13** (pitch diameter $D_p = 150$ mm, pressure angle $\alpha = 20^\circ$) is supported by a pair of tapered roller bearings, 4T-32206 ($C_r = 54.5$ kN {5,600 kgf}) and 4T-32205 ($C_r = 42$ kN {4300 kgf}). Find rating life for each bearing when gear transfer power $H = 150$ kW and rotational speed $n = 2,000$ min⁻¹.

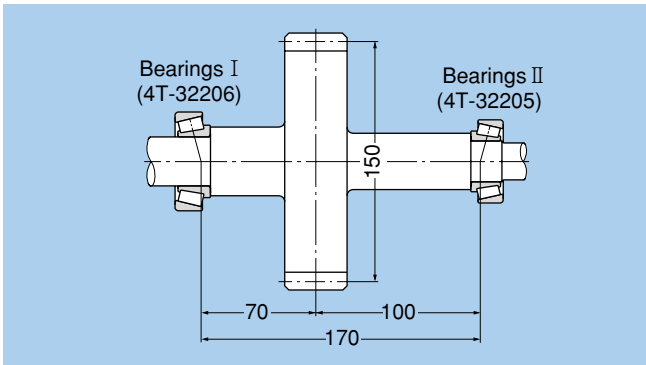

Fig. 4.13 Spur gear diagram

The gear load from formulas (4.2), (4.3a) and (4.4) is:

$$K_t = \frac{19.1 \times 10^6 \cdot H}{D_p \cdot n} = \frac{19,100 \times 150}{150 \times 2,000} = 9.55 \text{ kN } \{974 \text{ kgf}\}$$

$$K_s = K_t \cdot \tan \alpha = 9.55 \times \tan 20^\circ = 3.48 \text{ kN } \{355 \text{ kgf}\}$$

$$K_r = \sqrt{K_t^2 + K_s^2} = \sqrt{9.55^2 + 3.48^2} = 10.16 \text{ kN } \{1,040 \text{ kgf}\}$$

The radial loads for bearings I and II are:

$$F_{rI} = \frac{100}{170} K_r = \frac{100}{170} \times 10.16 = 5.98 \text{ kN } \{610 \text{ kgf}\}$$

$$F_{rII} = \frac{70}{170} K_r = \frac{70}{170} \times 10.16 = 4.18 \text{ kN } \{426 \text{ kgf}\}$$

$$\frac{0.5F_{rI}}{Y_I} = 1.87 > \frac{0.5F_{rII}}{Y_{II}} = 1.25$$

From **Table 4.5**, equivalent radial load:

$$P_{rI} = F_{rI} = 5.98 \text{ kN } \{610 \text{ kgf}\}$$

$$P_{rII} = XF_{rII} + Y_{II} \frac{0.5F_{rI}}{Y_I} = 0.4 \times 4.18 + 1.67 \times 1.87 = 4.79 \text{ kN } \{489 \text{ kgf}\}$$

From formula (3.5) and **Fig. 3.1** the life factor, f_h , for each bearing is:

$$f_{hI} = f_h \frac{C_{rI}}{P_{rI}} = 0.293 \times 54.5 / 5.98 = 2.67$$

$$f_{hII} = f_h \frac{C_{rII}}{P_{rII}} = 0.293 \times 42.0 / 4.79 = 2.57$$

Therefore: $a_2 = 1.4$ (4T-tapered roller bearings shown in **B-144**)

$$L_{h1} = 13,200 \times a_2 = 13,200 \times 1.4 = 18,480 \text{ hour}$$

$$L_{h2} = 11,600 \times a_2 = 11,600 \times 1.4 = 16,240 \text{ hour}$$

The combined bearing life, L_h , from formula (3.3) is:

$$L_h = \frac{1}{\left[\frac{1}{L_{h1}^e} + \frac{1}{L_{h2}^e} \right]^{1/e}}$$

$$= \frac{1}{\left[\frac{1}{18,480^{9/8}} + \frac{1}{16,240^{9/8}} \right]^{8/9}}$$

$$= 9,330 \text{ hour}$$

(Example 5)

Find the mean load for spherical roller bearing **23932** ($L_a = 320 \text{ kN}$ {33,000 kgf}) when operated under the fluctuating conditions shown in **Table 4.6**.

Table 4.6

Condition No. i	Operating time ϕ_i %	Radial load F_{ri} kN { kgf }	Axial load F_{ai} kN { kgf }	Revolution n_i min ⁻¹
1	5	10 { 1020 }	2 { 204 }	1200
2	10	12 { 1220 }	4 { 408 }	1000
3	60	20 { 2040 }	6 { 612 }	800
4	15	25 { 2550 }	7 { 714 }	600
5	10	30 { 3060 }	10 { 1020 }	400

The equivalent radial load, P_r , for each operating condition is found by using formula (4.17) and shown in **Table 4.7**. Because all the values for F_{ri} and F_{ai} from the bearing tables are greater than $F_a / F_r > e = 0.18$, $X = 0.67$, $Y_2 = 5.50$.

$$P_{ri} = XF_{ri} + Y_2 F_{ai} = 0.67F_{ri} + 5.50F_{ai}$$

From formula (4.12) the mean load, F_m , is:

$$F_m = \left[\frac{\sum (P_{ri}^{10/3} \cdot n_i \cdot \phi_i)}{\sum (n_i \cdot \phi_i)} \right]^{3/10} = 48.1 \text{ kN} \{4,906 \text{ kgf}\}$$

Table 4.7

Condition No. i	Equivalent radial load. P_{ri} kN { kgf }
1	17.7 { 1805 }
2	30.0 { 3060 }
3	46.4 { 4733 }
4	55.3 { 5641 }
5	75.1 { 7660 }

(Example 6)

Find the threshold values for rating life time and allowable axial load when cylindrical roller bearing NUP312 is used under the following conditions: Provided that intermittent axial load and oil lubricant.

Radial load $F_r = 10 \text{ kN}$ {1,020 kgf}

Rotational speed $n = 2,000 \text{ min}^{-1}$

Radial load is:

$$P_r = F_r = 10 \text{ kN} \{1,020 \text{ kgf}\}$$

The speed factor of cylindrical roller bearing, f_n , at $n = 2,000 \text{ min}^{-1}$, from **Table 3.1**

$$f_n = \left[\frac{33.3}{2,000} \right]^{3/10} = 0.293$$

The life factor, f_h , from formula (3.4)

$$f_h = 0.293 \times \frac{124}{10} = 3.63$$

Therefore the basic rated life, L_{10h} , from **Table 3.1**

$$L_{10h} = 500 \times 3.63^{10/3} \approx 37,000$$

And next, allowable axial load of cylindrical roller bearing is shown in page B-93.

In formula (1) on page B-93, based on NUP312 from Table 4 on page B-93, $k = 0.065$.

$$d_p = (60 + 130)/2 = 95 \text{ mm}, n = 2,000 \text{ min}^{-1}$$

Take into consideration that intermittent axial load.

$$d_p \cdot n \times 10^4 = 19 \times 10^4$$

In **Fig. 1** on page B-93, $d_p \cdot n = 19 \times 10^4$. In the case of intermittent axial load, allowable surface pressure at the lip $P_t = 40 \text{ MPa}$.

Therefore the allowable axial load, P_t , following

$$P_z = 0.065 \times 60^2 \times 40 = 9,360 \text{ N} \{954 \text{ kgf}\}$$

Based on **Table 4** of page B-93, it is within the limits of $F_{a \text{ max}} < 0.4 \times 10,000 = 4,000 \text{ N}$. Therefore $P_t < 4,000 \text{ N}$ {408 kgf}.