



Split plummer block housings SED 30, 31, 32 and 39 series

Bearing types

- Spherical roller bearings

Bearing dimension series

- 30, 31, 32 and 39

Shaft diameter range

- 430 to 900 mm

Typical shaft-bearing combinations

- Plain shaft with bearing on an adapter sleeve
- Stepped shaft with bearing on a cylindrical seat

Seal

- Multi-seal

Lubrication

- Grease
- Oil

Material

- Spheroidal graphite cast iron

Mounting

- Eight-bolt mounting

Compliance to standards

- Not standardized

SED plummer (pillow) block housings are large split housings designed to accommodate heavy loads acting perpendicular toward the support surface within an angle of $\pm 55^\circ$. These types of loads are typically encountered in conveyors, mills and crushers.

Split plummer block housings SED 30, 31, 32 and 39 series

Designations	333	Product tables	
Standard housing design	334	6.1 SED plummer block housings	
Features and benefits	334	for bearings on an adapter sleeve ..	344
Housing material	336		
Paint, corrosion protection	336		
Dimension standards	336		
Housing variants	336		
Housings for circulating oil			
lubrication systems	336		
Sealing solutions	337		
Multi-seals	337		
End covers	337		
Design considerations	338		
Typical shaft-bearing combinations ...	338		
Locating and non-locating			
bearing positions	338		
Load carrying ability	338		
Operating temperature	340		
Operating speed	340		
Attachment bolt recommendations ...	340		
Lubrication	342		
Initial grease fill	342		
Relubrication	342		
Oil lubrication	342		
Mounting	342		
Torque specifications	342		
Supporting the housing	343		
Eye bolts	343		
Condition monitoring	343		
Accessories	343		
Ordering information	343		

Designations

Designation system for SED plummer block housings

SED 31/530 AL

Series

SED Standard plummer block housing, spheroidal graphite cast iron

Size identification

30.. Housing for bearings in the 30 dimension series
31.. Housing for bearings in the 31 dimension series
32.. Housing for bearings in the 32 dimension series
39.. Housing for bearings in the 39 dimension series
..92 and ..96 Size code, related to the bearing bore size
../500 to /950 Size code, related to the bearing bore size

Suffixes¹⁾

– Housing for plain shaft with bearing on an adapter selevel
G Housing for stepped shaft with bearing on a cylindrical seat
A Housing for shaft end, one side closed
B Housing for a through shaft
F Housing for the locating bearing position
L Housing for the non-locating bearing position
RT Housing prepared for circulating oil lubrication
V Grease escape hole in the cover
P01 to P.. Paint variant according to customer specification (no symbol indicates SKF standard paint)

¹⁾ When multiple suffixes are used, they are listed in the same order as they appear here.

Split plummer block housings SED 30, 31, 32 and 39 series

Standard housing design

SED plummer (pillow) block housings are large symmetrical, split housings consisting of a housing base, cap and two split covers (→ **fig. 1**). The covers are bolted to the base/cap with hexagon head bolts on each side. The housings have eight drilled attachment bolts holes in the base as standard. Two cast holes in the cap facilitate handling.

The SED housing series consists of six different housing bodies. Each housing body can accommodate multiple bearing series and sizes. The bearing envelope, the outside diameter and width, determine the cover design and the dimensions of both the cover and bearing seat.

Features and benefits

SED plummer block housings have the following features and benefits:

Stiff housing

Standard SED housings are made of spheroidal graphite cast iron. The housings are reinforced with ribs in the base, an integral flange on the cap, and additional material around the attachment bolt holes (→ **fig. 2**). This design contributes to the overall stiffness of the housing and minimizes the total weight.

Easy mounting

The housing base and cap are held together by four Superbolt® multi-jack tensioners (up to size M 80) (→ **fig. 3**). Each bolt consists of 10 to 14 M 16 hexagon head bolts that can be installed easily by one person using a torque wrench.

Machined base ends

SED housings have machined base ends. This makes alignment easier and provides good contact with stops when they are used (→ **fig. 4**).

Safe, easy handling

All housing parts are prepared for safe, easy handling and lifting. There are two holes cast into the integral flange on the cap (→ **fig. 5**). The housing base and covers can be lifted with eye bolts inserted into existing threaded holes.

Condition monitoring

SED housings are supplied standard with a wireless condition monitoring node and sensor CMWA 8800 (→ **fig. 6**). The sensor measures velocity, acceleration and temperature. The signals from the sensor can be integrated easily into a condition monitoring network.

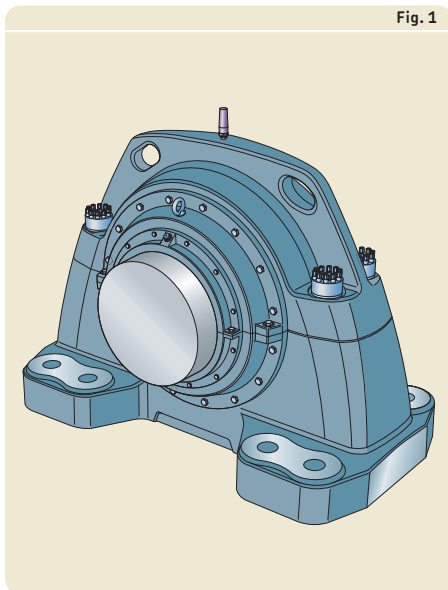

Standard housing design

Fig. 4

Machined base ends

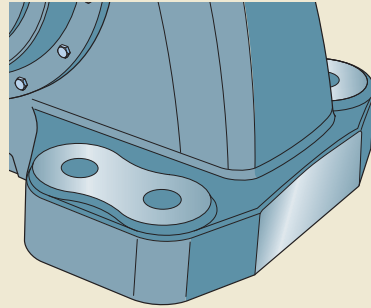

Fig. 2

Stiff housing

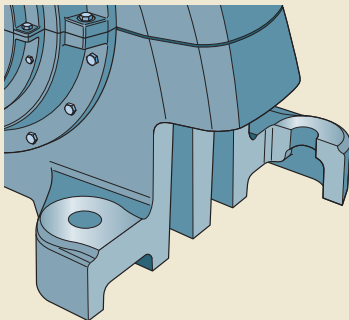

Fig. 5

Lifting holes

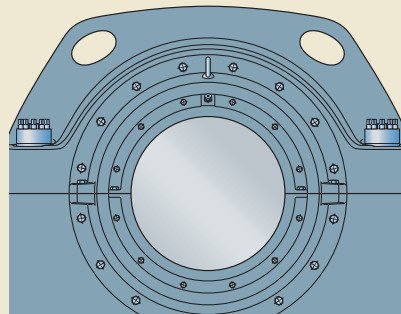

Fig. 3

Superbolts

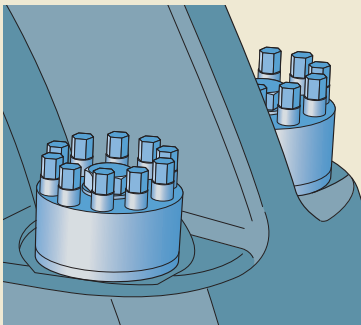
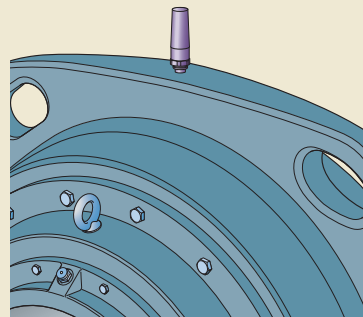

Fig. 6

Condition monitoring node and sensor



Split plummer block housings SED 30, 31, 32 and 39 series

Housing material

SED plummer block housings are made of spheroidal graphite cast iron.

Paint, corrosion protection

SED housings are painted graphite grey (RAL design 000 30 00) using a water based alkyd/acryl paint. The paint protects the housing in accordance with ISO 12944-2, corrosivity category C3, i.e. exterior atmospheres with a moderate level of pollution; coastal areas with low salinity; interior atmospheres with high humidity and some air pollution (→ *Environmental conditions*, page 36). The paint is not affected by most lubricating or engine oils, cutting fluids or alkalescent washing chemicals. Housings can be repainted with most water or solvent based 1- or 2-component paints.

Unpainted surfaces are protected by a solventless rust inhibitor.

Dimension standards

The dimensions of SED housings are not standardized either nationally or internationally.

Housing variants

In addition to standard design SED housings, a number of variants are also available. Variants include housings painted to other colours and corrosivity categories, housings with a narrower base and differently positioned attachment bolt holes, housings suitable for bearings on a cylindrical seat on stepped shafts, and housings modified for circulating oil lubrication.

For additional information, contact the SKF application engineering service.

Housings for circulating oil lubrication systems

Housings modified for circulating oil lubrication systems have a threaded oil outlet hole in each cover (designation suffix RT). The tapped hole used for grease relubrication can be used as the oil inlet.

Sealing solutions

Multi-seals

SED plummer block housings are supplied standard with a multi-seal on each side, which consists of an integrated labyrinth seal and a three stage labyrinth ring. An O-ring holds the labyrinth ring in place on the shaft. The radial shaft seal is installed in the radial seal cover, which is then mounted onto the labyrinth seal cover.

The multi-seal is designed for both grease and circulating oil lubrication. The seal can be relubricated via a grease fitting in the radial seal cover (→ **fig. 7**).

Table 1 provides an overview of the characteristics and suitability of the multi-seal. This information should be used a guideline, which cannot substitute for testing a seal in its application.

End covers

SED housings are supplied with a cover for either shaft ends or through shafts:

- Housings with a cover for shaft ends have the designation suffix A.
- Housings with a cover for through shafts have the designation suffix B.

For details about the permissible length of the shaft end, contact the SKF application engineering service.

Fig. 7

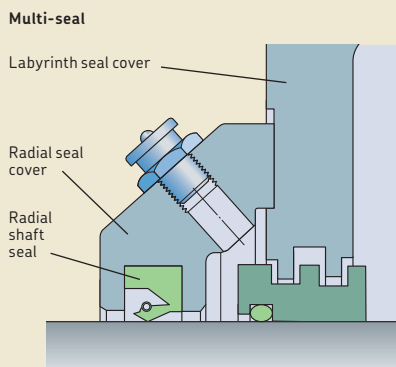

Table 1

Multi-seals for SED plummer block housings

Seal	
Type	Integrated labyrinth and radial shaft seal
Material	grey cast iron, nitrile rubber
Application conditions and requirements	
Temperature [°C]	-40 to +100
Temperature [°F]	-40 to +210
Max. circumferential speed ¹⁾ [m/s]	7,5
Max. misalignment [°]	0,3
Low friction	suitable
Shaft tolerance class	h9
Shaft roughness R _a [μm]	≤ 3,2
Sealing suitability	
Dust	++
Fine particles	++
Coarse particles	++
Chips	++
Liquids when sprayed	+
Direct sunlight	++
Symbols: ++ very suitable	+ suitable

¹⁾ Limited by the radial shaft seal

Split plummer block housings SED 30, 31, 32 and 39 series

Design considerations

For general information about system design, refer to the following sections:

- *Typical shaft-bearing combinations* (→ page 41)
- *Locating/non-locating bearing systems* (→ page 40)
- *Load carrying ability* (→ page 44)
- *Axial load carrying ability for bearings on a sleeve* (→ page 44)
- *Specifications for shafts and housing support surfaces* (→ page 45)

For additional information about rolling bearings and adapter sleeves, refer to the product information available online at skf.com/bearings.

Typical shaft-bearing combinations

SED housings can accommodate different shaft-bearing combinations:

- plain shaft with bearing on an adapter sleeve (→ fig. 8)
- stepped shaft with bearing on a cylindrical seat

Plain shaft with bearing on an adapter sleeve

This arrangement is standard for SED housings. Housings, appropriate parts and dimensions are listed in **product table 6.1** starting on **page 344**.

Stepped shaft with bearing on a cylindrical seat

Housings to accommodate this shaft arrangement are available on request. For additional information, contact the SKF application engineering service.

Locating and non-locating bearing positions

SED housings can be used for both the locating and non-locating bearing positions and are supplied in two designs:

- Housings with the designation suffix F have a bearing seat that matches the bearing width. These housings should be used for spherical roller bearings in the locating position and CARB toroidal roller bearings in the non-locating position.
- Housings with the designation suffix L have a bearing seat that is wider than the bearing. These housings should be used for spherical roller bearings in the non-locating position. The possible axial displacement of the bearing is listed in the product tables (parameter "s").

Load carrying ability

SED housings are intended for loads acting perpendicularly toward the support surface within an angle of $\pm 55^\circ$. If loads acting in other directions occur, contact the SKF application engineering service.

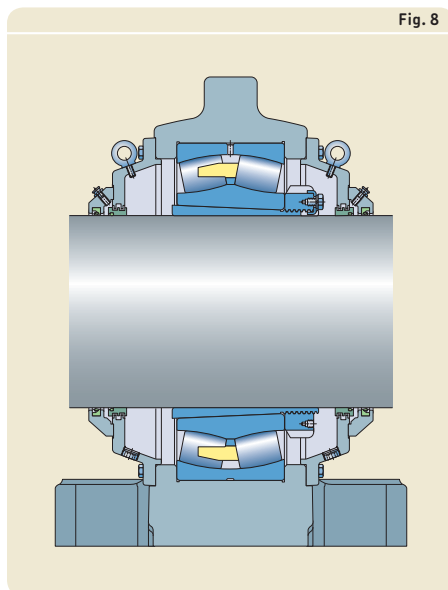

Breaking loads and safety factors

Guideline values for the breaking loads for housings made of spheroidal graphite cast iron are listed in **table 2**. To obtain the permissible load for a housing, the appropriate breaking load value should be divided by a factor based on the safety requirements. In general engineering, a safety factor of 6 is typical (→ *Load carrying ability*, **page 44**).

The permissible load can only be exploited if the cap bolts are tightened at least to the torque values listed in **table 3** on **page 339**.

If the housing is not supported over its entire base, the load carrying capacity may be affected. For additional information, contact the SKF application engineering service.

Additional housing support

When loads acting parallel to the support surface occur, a sufficiently strong stop should be provided to counter the load.

Table 2

Breaking loads for SED plummer block housings

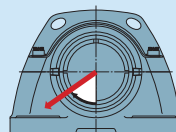

P_{55°

Housing body Size	Breaking loads P_{55°
–	kN
1	26 000
2	30 000
3	35 000
4	48 000
5	37 000
6	69 000

Table 3

Tightening torque values for cap bolts

Housing body Size	Cap bolts (Superbolts) Designation to ISO 262 Grade 10.9 bolt body	Jack bolt Size	Tightening torque
–	–		Nm
1	SB12-M 68x6x300/W	M 16x1,5	350
2	SB12-M 68x6x300/W	M 16x1,5	350
3	SB12-M 72x6x300/W	M 16x1,5	350
4	SB12-M 80x6x350/W	M 16x1,5	350
5	SB12-M 80x6x350/W	M 16x1,5	350
6	SB12-M 80x6x350/W	M 16x1,5	350

Split plummer block housings SED 30, 31, 32 and 39 series

Operating temperature

The permissible operating temperature is mainly limited by the seal (→ **table 3, page 339**) and the lubricant in the bearing. For temperature limits of SKF bearings and lubricants, refer to the product information available online at skf.com/bearings.

The housing material does not have any additional temperature limits, except for very low temperature applications where impact strength could be a factor.

The housing paint is heat resistant up to 80 °C (175 °F) material temperature or 100 °C (210 °F) ambient temperature.

When temperatures outside the permissible range are expected, contact the SKF application engineering service.

Operating speed

The seals can limit the permissible operating speed. They are suitable for circumferential speeds of up to 7,5 m/s.

For speed limits of the bearing, refer to the product information available online at skf.com/bearings.

Attachment bolt recommendations

SKF recommends using Superbolt multi-jack tensioners as attachment bolts for easier and more reliable mounting compared to standard hexagon head bolts. In typical applications, 10.9 class hexagon head bolts in accordance with ISO 4014 can be used together with washers. If the load does not act perpendicularly toward the base, it may be necessary to use stronger, 12.9 class bolts.

Torque values for cover bolts and attachment bolts

Housing body Size	Cover bolts Cover Size	Tightening torque	Radial seal cover Size	Tightening torque
–	–	Nm	–	Nm
1	M 16/M 24	200/665	M 10	50
2	M 16/M 24	200/665	M 10	50
3	M 16/M 24	200/665	M 10	50
4	M 16/M 24	200/665	M 10	50
5	M 16/M 24	200/665	M 10	50
6	M 16/M 24	200/665	M 10	50

¹⁾ L = length

SKF housings can withstand loads resulting from tightening the attachment bolts to the torque values typically recommended by bolt manufacturers (→ **table 4**). They are valid for oiled, but otherwise untreated thread surfaces. Hexagon head bolts tightened to the recommended torque value cannot accommodate any load in the direction of the bolt axis. SKF cannot guarantee that tightening to the recommended value provides sufficient anchoring. Make sure that attachment bolts, dowels or stops, and a sufficiently strong support can accommodate all occurring loads.

Table 4

Housing body Size	Attachment bolts Superbolts Grade 10.9 bolt body ¹⁾	Jack bolt Size	Tightening torque	Hexagon head bolts	
				Size	Tightening torque
–	–		Nm	–	Nm
1	SB12-M72x6xL/W	M16x1,5	350	M72	1975
2	SB12-M72x6xL/W	M16x1,5	350	M72	1975
3	SB12-M80x6xL/W	M16x1,5	350	M80	2465
4	SB12-M80x6xL/W	M16x1,5	350	M80	2465
5	SB12-M80x6xL/W	M16x1,5	350	M80	2465
6	SB12-M80x6xL/W	M16x1,5	350	M80	2465

Split plummer block housings SED 30, 31, 32 and 39 series

Lubrication

SED plummer block housings are intended for both grease and circulating oil lubrication systems. The lubricant should be selected based on the operating conditions of the bearing. For additional information about lubricant selection, refer to the product information available online at skf.com/bearings.

Initial grease fill

If no other requirements exist, the free space in the bearing as well as the gaps of the labyrinth seal should be completely filled with grease and the free space in the housing should be filled to 20% of its volume. For highly contaminated environments and slow speeds, fill the housing to 70–80%.

For additional information, contact the SKF application engineering service.

Relubrication

SED plummer block housings enable relubrication of the incorporated bearings and seals. They have two holes that have been drilled and tapped for a button-head grease fitting (→ **fig. 9**). The holes are in accordance with DIN 3404 and used to relubricate spherical roller bearings with a relubrication feature (a lubrication groove and holes in the outer ring). When applying grease via the relubrication feature, the shaft should be rotating.

Oil lubrication

SED housings with the designation suffix RT can be used for circulating oil lubrication systems. The same holes that are used for grease relubrication (via the annular groove and lubrication holes in the outer ring of the bearing) can be used as the oil inlet.

Mounting

SED housings must be mounted properly using the appropriate tools and state of the art mechanical mounting methods. All the associated components must also meet certain basic requirements (→ *Specifications for shafts and housing support surfaces*, **page 45**). For information about mounting rolling bearings, refer to the *SKF bearing maintenance handbook* or skf.com/mount.

Torque specifications

Cap, cover and attachment bolts should be tightened to the torque values listed in **tables 3 and 4, pages 339 and 340**. The cover bolts are in accordance with ISO 4017. For information about attachment bolts, refer to *Attachment bolt recommendations* on **page 340**.

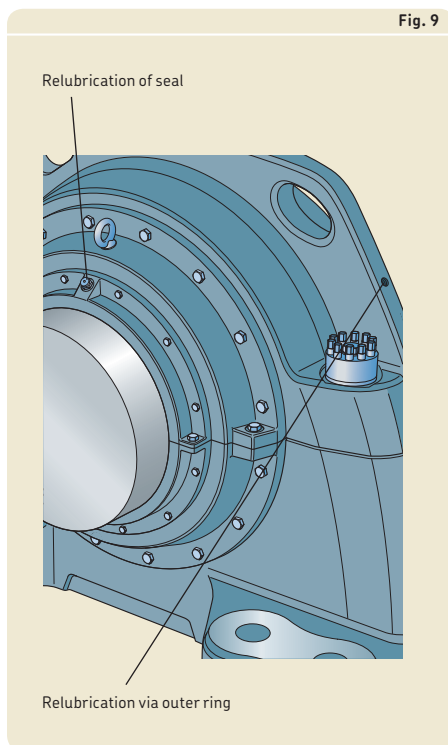

Supporting the housing

A stop should be used to accommodate loads acting parallel to the support surface. The stop also makes alignment during mounting easier.

Eye bolts

All separate components are prepared for lifting. There is an integral flange on the cap with two cast holes. The housing base can be lifted with eye bolts inserted into the threaded holes for the cap bolts.

Various threaded holes in the covers can be used for inserting eye bolts.

Condition monitoring

SED housings are equipped with a wireless vibration sensor, CMWA 8800, as standard. The CMWA 8800 Wireless Condition Monitoring Node is a combined sensor and wireless communication node that measures both vibration and temperature. The device uses the WirelessHART communication protocol, which offers a simple, reliable and secure means of transmitting machine vibration and temperature data wirelessly back to a host computer network.

SED housings also have additional positions for other sensors (→ **fig. 10**).

Accessories

There are several accessories available for SED housings, including centralized lubrication systems and condition monitoring sensors. For additional information, refer to *SKF tools and products* (→ **page 47**).

Ordering information

SED housings are supplied with the appropriate covers, multi-seals and a wireless condition monitoring sensor. Bearings and adapter sleeves must be ordered separately.

Fig. 10

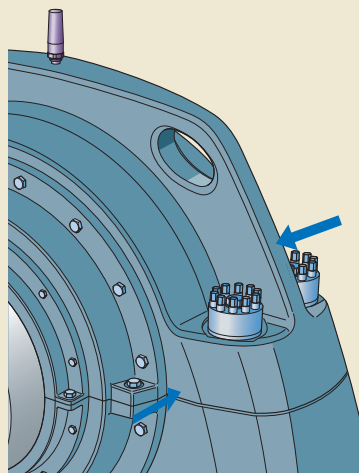

Order example

Two plummer block housings are required for two 230/560 CAK/W33 spherical roller bearings on OH 30/560 H adapter sleeves. One housing will accommodate the non-locating bearing at the end of the shaft. The other housing will accommodate the locating bearing and a through shaft.

The following items should be ordered:

- 1 housing SED 30/560 BF
- 1 housing SED 30/560 AL

6.1 SED plummer block housings for bearings on an adapter sleeve

d_a 430 – 750 mm

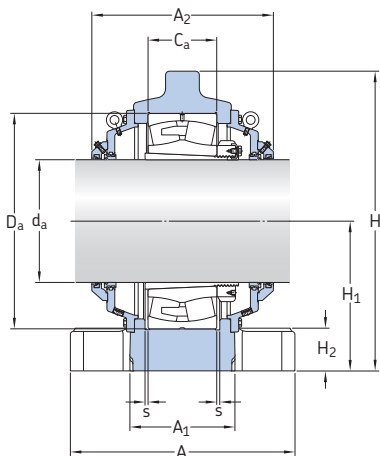

Shaft diameter d_a	Housing	Appropriate parts Bearing	Adapter sleeve	Mass Housing	Housing body Size
mm	–	–		kg	–
430	SED 3292	23292 CAK/W33	OH 3292 H	2 300	1
450	SED 3296	23296 CAK/W33	OH 3296 H	2 900	2
470	SED 31/500 SED 32/500	231/500 CAK/W33 232/500 CAK/W33	OH 31/500 H OH 32/500 H	2 300 3 550	1 4
500	SED 31/530 SED 32/530	231/530 CAK/W33 232/530 CAK/W33	OH 31/530 H OH 32/530 H	2 300 3 550	1 4
530	SED 30/560 SED 31/560 SED 32/560	230/560 CAK/W33 231/560 CAK/W33 232/560 CAK/W33	OH 30/560 H OH 31/560 H OH 32/560 H	2 300 2 900 3 550	1 2 4
560	SED 39/600 SED 30/600 SED 31/600 SED 32/600	239/600 CAK/W33 230/600 CAK/W33 231/600 CAK/W33 232/600 CAK/W33	OH 39/600 H OH 30/600 H OH 31/600 H OH 32/600 H	2 300 2 300 3 550 3 550	1 1 4 4
600	SED 39/630 SED 30/630 SED 31/630	239/630 CAK/W33 230/630 CAK/W33 231/630 CAK/W33	OH 39/630 H OH 30/630 H OH 31/630 H	2 300 2 900 3 550	1 2 4
630	SED 39/670 SED 30/670 SED 31/670 SED 32/670	239/670 CAK/W33 230/670 CAK/W33 231/670 CAK/W33 232/670 CAK/W33	OH 39/670 H OH 30/670 H OH 31/670 H OH 32/670 H	2 900 2 900 4 175 6 500	2 2 5 6
670	SED 39/710 SED 30/710 SED 31/710 SED 32/710	239/710 CAK/W33 230/710 CAK/W33 231/710 CAK/W33 232/710 CAK/W33	OH 39/710 H OH 30/710 H OH 31/710 H OH 32/710 H	2 900 3 600 4 175 6 500	2 3 5 6
710	SED 39/750 SED 30/750 SED 31/750 SED 32/750	239/750 CAK/W33 230/750 CAK/W33 231/750 CAK/W33 232/750 CAK/W33	OH 39/750 H OH 30/750 H OH 31/750 H OH 32/750 H	2 900 3 600 6 500 6 500	2 3 6 6
750	SED 39/800 SED 30/800 SED 31/800	239/800 CAK/W33 230/800 CAK/W33 231/800 CAK/W33	OH 39/800 H OH 30/800 H OH 31/800 H	3 600 4 175 6 500	3 5 6

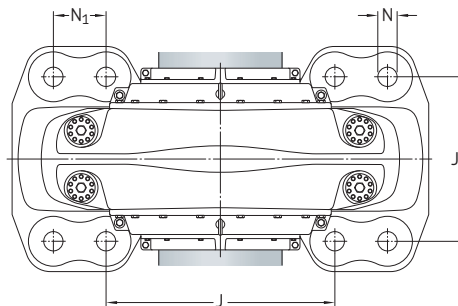
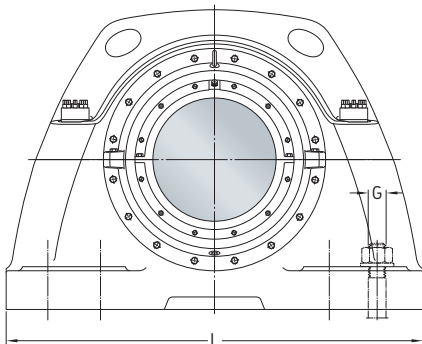

6.1

Shaft diameter **Dimensions**

d_a	A	A_1	A_2	D_a	C_a	H	H_1	H_2	J	J_1	L	N	N_1	G	s
mm	mm														
430	860	400	726	830	296	1150	575	165	880	630	1600	76	200	72	8
450	920	450	776	870	310	1230	630	175	940	700	1700	76	205	72	9
470	860	400	726	830	264	1150	575	165	880	630	1600	76	200	72	8
	1000	500	826	920	336	1325	675	195	1100	780	1900	84	210	80	9
500	860	400	726	870	272	1150	575	165	880	630	1600	76	200	72	9
	1000	500	826	980	355	1325	675	195	1100	780	1900	84	210	80	10
530	860	400	726	820	195	1150	575	165	880	630	1600	76	200	72	8
	920	450	776	920	280	1230	630	175	940	700	1700	76	205	72	9
	1000	500	826	1030	365	1325	675	195	1100	780	1900	84	210	80	10
560	860	400	726	800	150	1150	575	165	880	630	1600	76	200	72	8
	860	400	726	870	200	1150	575	165	880	630	1600	76	200	72	9
	1000	500	826	980	300	1325	675	195	1100	780	1900	84	210	80	10
	1000	500	826	1090	388	1325	675	195	1100	780	1900	84	210	80	11
600	860	400	726	850	165	1150	575	165	880	630	1600	76	200	72	8
	920	450	776	920	212	1230	630	175	940	700	1700	76	205	72	9
	1000	500	826	1030	315	1325	675	195	1100	780	1900	84	210	80	10
630	920	450	776	900	170	1230	630	175	940	700	1700	76	205	72	9
	920	450	776	980	230	1230	630	175	940	700	1700	76	205	72	10
	1000	480	806	1090	336	1650	840	215	1300	770	2100	84	210	80	11
	1200	600	926	1220	438	1715	840	215	1350	920	2200	84	210	80	12
670	920	450	776	950	180	1230	630	175	940	700	1700	76	205	72	9
	900	420	746	1030	236	1350	675	195	1110	685	1900	84	210	80	10
	1000	480	806	1150	345	1650	840	215	1300	770	2100	84	210	80	11
	1200	600	926	1280	450	1715	840	215	1350	920	2200	84	210	80	13
710	920	450	776	1000	185	1230	630	175	940	700	1700	76	205	72	10
	900	420	746	1090	250	1350	675	195	1110	685	1900	84	210	80	11
	1200	600	926	1220	365	1715	840	215	1350	920	2200	84	210	80	12
	1200	600	926	1360	475	1715	840	215	1350	920	2200	84	210	80	14
750	900	420	746	1060	195	1350	675	195	1110	685	1900	84	210	80	11
	1000	480	806	1150	258	1650	840	215	1300	770	2100	84	210	80	11
	1200	600	926	1280	375	1715	840	215	1350	920	2200	84	210	80	13

6.1 SED plummer block housings for bearings on an adapter sleeve

d_a 800 – 900 mm

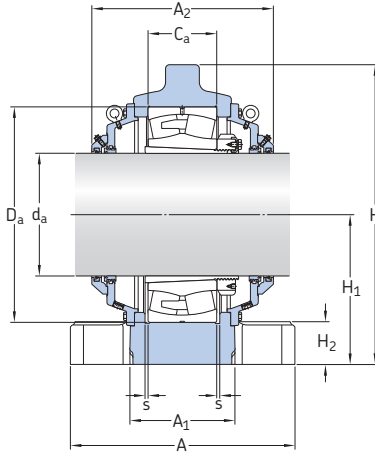

Shaft diameter	Housing	Appropriate parts Bearing	Adapter sleeve	Mass Housing	Housing body Size
d_a					
mm	–	–		kg	–
800	SED 39/850	239/850 CAK/W33	OH 39/850 H	3 600	3
	SED 30/850	230/850 CAK/W33	OH 30/850 H	4 175	5
	SED 31/850	231/850 CAK/W33	OH 31/850 H	6 500	6
850	SED 39/900	239/900 CAK/W33	OH 39/900 H	3 600	3
	SED 30/900	230/900 CAK/W33	OH 30/900 H	4 175	5
900	SED 39/950	239/950 CAK/W33	OH 39/950 H	4 175	5
	SED 30/950	230/950 CAK/W33	OH 30/950 H	4 175	5

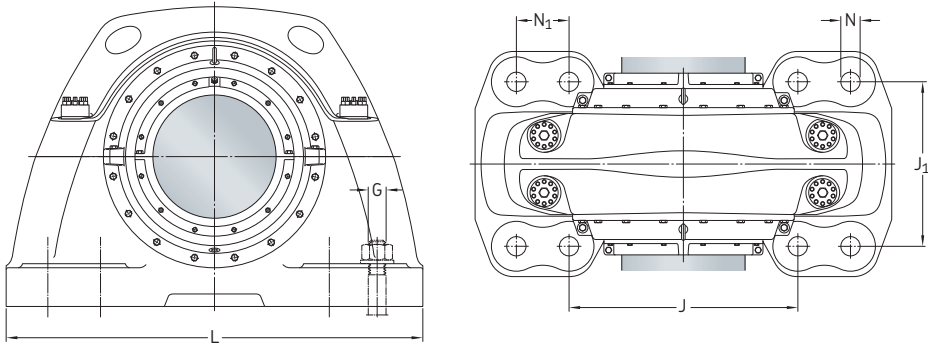

Shaft diameter Dimensions

d_a	A	A_1	A_2	D_a	C_a	H	H_1	H_2	J	J_1	L	N	N_1	G	s
mm	mm														
800	900	420	746	1120	200	1350	675	195	1110	685	1900	84	210	80	11
	1000	480	806	1220	272	1650	840	215	1300	770	2100	84	210	80	12
	1200	600	926	1360	400	1715	840	215	1350	920	2200	84	210	80	14
850	900	420	746	1180	206	1350	675	195	1110	685	1900	84	210	80	12
	1000	480	806	1280	280	1650	840	215	1300	770	2100	84	210	80	13
900	1000	480	806	1250	224	1650	840	215	1300	770	2100	84	210	80	12
	1000	480	806	1360	300	1650	840	215	1300	770	2100	84	210	80	14