

BELLOWS COUPLINGS

SERIES BK | 15 – 10,000 Nm



R+W[®]
COUPLING TECHNOLOGY

THE ULTIMATE COUPLING FROM 15 – 10,000 Nm

TORSIONALLY STIFF METAL BELLOWS COUPLINGS

Areas of application:

- Servo drives
- CNC axes
- Robotic axes
- Manipulators
- Linear actuators
- Printing machines
- Packaging machines
- Woodworking machines
- Textile machinery
- Metal cutting machines

Properties of the product range:

- zero backlash
- high torsional stiffness
- exact transmission of angular motion and torque
- infinite life
- wear and maintenance free
- easy mounting and dismounting
- compensation of axial, lateral and angular shaft misalignment accompanied by quiet, uniform operation

MODEL

PROPERTIES

APPLICATION EXAMPLES

BK1

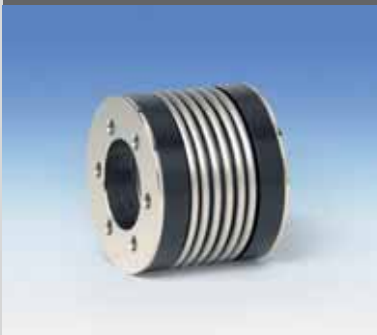

with flange mounting
from 15-10,000 Nm

- special design application

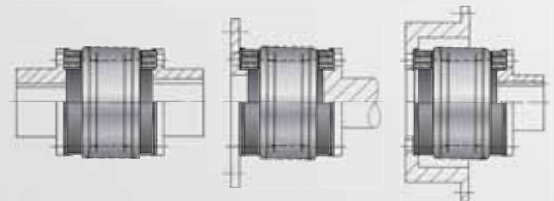

see page 5

BK 2



with clamping hub
from 15-1,500 Nm

- easy to mount
- suited for space restricted installations
- low moment of inertia
- finely balanced up to 40,000 rpm

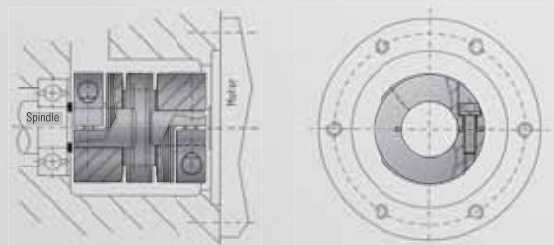

see page 6

BKH



with split hub
from 15-1,500 Nm

- for radial mounting
- suited for space restricted installations
- low moment of inertia
- finely balanced up to 40,000 rpm

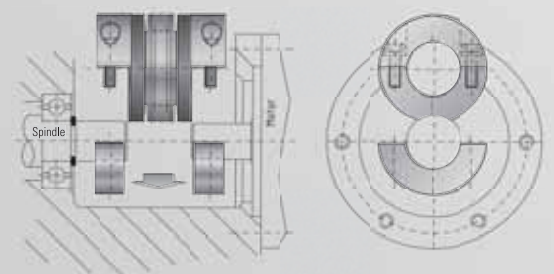

see page 7



MODEL

PROPERTIES

APPLICATION EXAMPLES

BKL



Economy Class with clamping hub from 2-500 Nm

- low cost version
- self opening clamping system optional

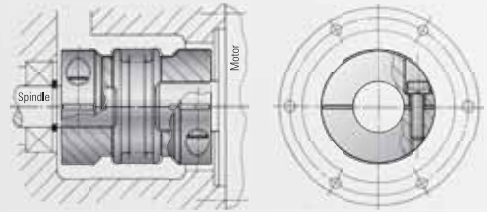

see separate catalog

BK 3



with tapered conical sleeves from 15-10,000 Nm

- high clamping forces
- high degree of operating dependability
- new draw off device suited for space restricted installations

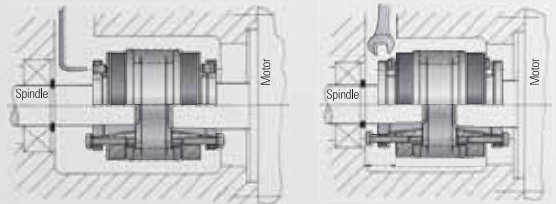

Approach to date

The new approach

see page 8

BK 4



for Fanuc-drives from 15-150 Nm

- for conical shaft mounting
- easy to assemble
- high clamping forces, due to conical sleeves

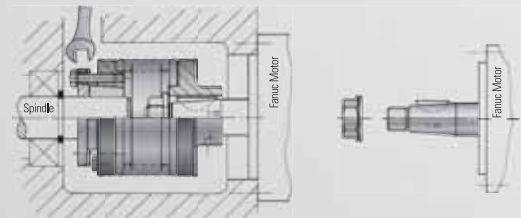

see page 9

BK 5



with tapered press-fit connection from 15-1,500 Nm

- absolutely backlash-free
- easy mounting and dismounting
- wear-free press fit connection
- electrically and thermally insulated

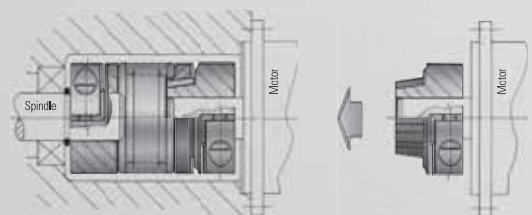

see page 10

TORSIONALLY STIFF METAL BELLOWS COUPLINGS

MODEL

PROPERTIES

APPLICATION EXAMPLES

BK 6



with conical sleeve and tapered press-fit connection from 15-1,500 Nm

- for axial mounting
- absolutely backlash-free
- easy mounting and dismounting
- wear-free press-fit connection
- electrically and thermally insulated
- high degree of operating dependability

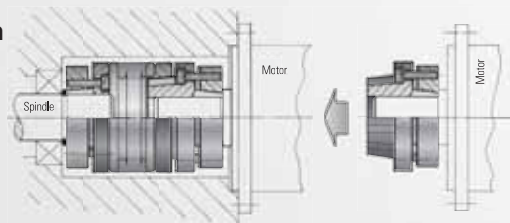

see page 11

BK 7



with expanding shaft from 15-300 Nm

- for hollow shaft mounting
- suited for space restricted installations
- easy mounting

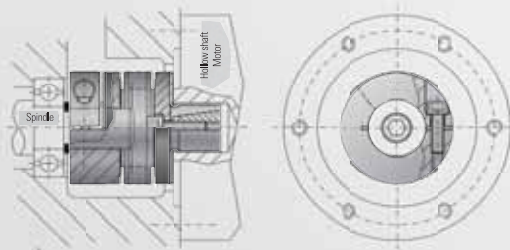

see page 12

ZA



Line shafts with clamping hub from 10-4,000 Nm

- removable intermediate tube section
- no additional bearing necessary
- standart length up to 6 m

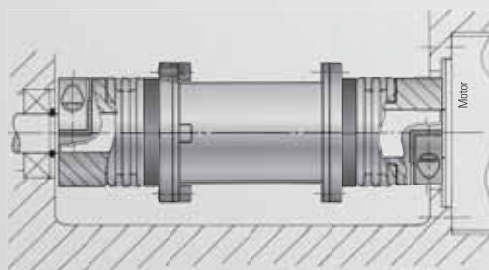

see separate catalogue

ATEX



for the use in explosive environments

- available for the full product range
- for hazardous areas 1/21 and 2/22 bellows couplings are registered according to the directive ATEX 95/137



see page 13

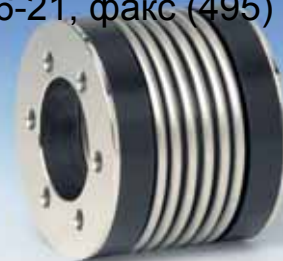

MODEL BK1

TECHNICAL SPECIFICATIONS

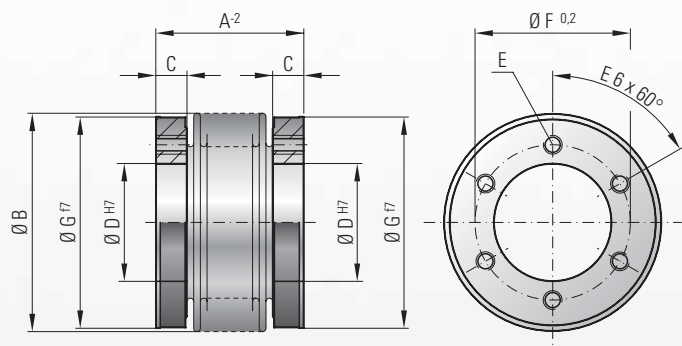

Properties:

Material:

Design:

Temperature range:

Speeds:

Service life:

Backlash:

Brief overloads:

Tolerance:

Non-standard application:

■ special design application

Bellows made of highly flexible high grade stainless steel, hub material: steel

The Hubs have six threaded metric mounting holes, and the ID and OD are concentrically machined to ISO H7 tolerances.

Hubs with custom bore size, mounting threads and bolt circles are available upon request.

-30 to +120° C (3.6 F - 270 F)

Up to 10,000 rpm, in excess of 10,000 with finely balanced version.

These couplings are maintenance-free if the technical limits are not exceeded

Absolutely backlash-free due to bolted connection.

Acceptable up to 1.5 times the value specified.

On the hub/shaft connection 0.01 to 0.05 mm

Custom designs with varied tolerances, keyways, non-standard material and bellows are available upon request.

Ordering example

BK1/150 / 62 / XX

Model
Series / Nm
Overall length
Non standard e.g. stainless steel

Model BK 1		Series																							
		15		30		60		150		200		300		500		800		1500		4000		6000		10000	
Rated torque (Nm)	T _{KN}	15		30		60		150		200		300		500		800		1500		4000		6000		10000	
Overall length (mm)	A	30	37	36	44	43	53	50	62	53	65	56	70	64	77	81	100	145	138	150					
Outer diameter of bellows (mm)	B	49		55		66		81		90		110		124		133		157		200		253		303	
Fit length thread depth (mm)	C	7.5		10		10		13		14		14		16		18		22		30		30		36	
Inner diameter H7 (mm)	D	25		28		38		50		58		65		70		75		85		100		145		190	
6 x fastening threads	E	M5		M5		M6		M6		M6		M8		M8		M10		M16		M20		8xM20		8xM24	
Hub bolt circle ± 0.2 (mm)	F	35		37		46		62		70		80		94		90		110		140		190		234	
Outer diameter f7 (mm)	G	49		55		66		81		90		110		122		116		140		182		235		295	
Moment of inertia (10 ⁻³ kgm ²)	J _{total}	0.07	0.08	0.14	0.15	0.30	0.32	0.90	0.95	1.30	1.40	1.95	2.10	3.0	3.4	4.3	10.6	46	132	350					
Approx. weight (kg)		0.15		0.2		0.3		0.6		0.8		1.5		1.4		1.6		3.3		8.9		13.9		23.7	
Torsional stiffness (10 ³ Nm/rad)	C _T	20	15	39	28	76	55	175	110	191	140	450	350	510	500	780	1304	3400	5700	10950					
axial	Max. values	1	2	1	2	1.5	2	2	3	2	3	2.5	3.5	2.5	3.5	3.5	3.5	3.5	3.5	3.5	3	3			
lateral		0.15	0.2	0.2	0.25	0.2	0.25	0.2	0.25	0.25	0.3	0.25	0.3	0.3	0.35	0.35	0.35	0.35	0.35	0.4	0.4	0.4			
angular		1	1.5	1	1.5	1	1.5	1	1.5	1	1.5	1	1.5	1	1.5	1.5	1.5	1.5	1.5	1.5	1.5	1.5			
axial spring stiffness (N/mm)	C _a	25	15	50	30	72	48	82	52	90	60	105	71	70	48	100	320	565	1030	985					
lateral spring stiffness (N/mm)	C _r	475	137	900	270	1200	420	1550	435	2040	610	3750	1050	2500	840	2000	3600	6070	19200	21800					

(1Nm ≅ 8.85 in lbs)



MODEL BK2

TECHNICAL SPECIFICATIONS

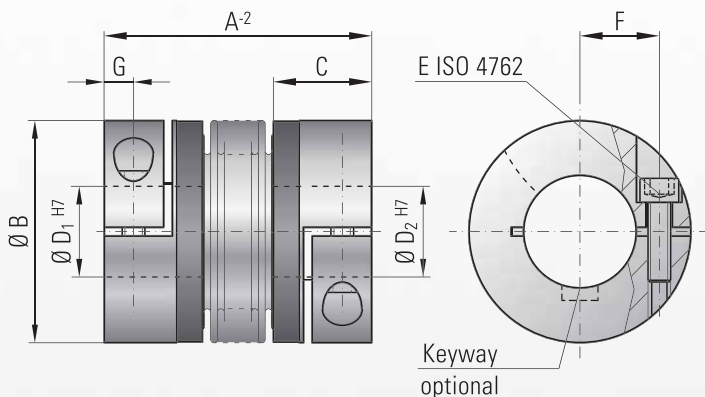

Ordering example

BK2 / 80 / 94 / 20 / 22 / XX

Model
Series / Nm
Overall length
Ø D1 H7
Ø D2 H7
Non standard e.g. stainless steel

Properties:

- easy to mount
- suited for space restricted installations
- low moment of inertia

Material:

Bellows made of highly flexible high-grade stainless steel, hub material: see table below

Design:

With a single radial clamping screw per hub ISO 4762. Any imbalance of the clamping hubs is compensated with balancing bores located on the inside of the hub.

Temperature range:

-30 to +120° C (3.6 F - 270 F)

Speeds:

Up to 10,000 rpm, in excess of 10,000 with a finely balanced version.

Service life:

These couplings are maintenance-free if the technical limits are not exceeded.

Backlash:

Absolutely backlash-free due to frictional clamped connection.

Brief overloads:

Acceptable up to 1.5 times the value specified.

Tolerance:

On the hub/shaft connection 0.01 to 0.05 mm

Non-standard application:

Custom designs with varied tolerances, keyways, non-standard material and bellows are available upon request.

Model BK 2		Series																			
		15		30		60		80		150		200		300		500		800		1500	
Rated torque (Nm)	T_{KN}	15		30		60		80		150		200		300		500		800		1500	
Overall length (mm)	A	59	66	69	77	83	93	94	106	95	107	105	117	111	125	133	146	140	166		
Outer diameter (mm)	B	49		55		66		81		81		90		110		124		134		157	
Fit length (mm)	C	22		27		31		36		36		41		43		51		45		55	
Inner diameter possible from Ø to Ø H7 (mm)	$D_{1/2}$	8-28		10-30		12-32		14-42		19-42		22-45		24-60		35-60		40-75		50-80	
ISO 4762 fastening screw	E	M5		M6		M8		M10		M10		M12		M12		M16		2xM16*		2xM20*	
Tightening torque of the fastening screw (Nm)		8	15		40		50		70		120		130		200		250		470		
Distance between centers (mm)	F	17		19		23		27		27		31		39		41		2x48		2x55	
(mm)	G	6.5		7.5		9.5		11		11		12.5		13		16.5		18		22.5	
Moment of inertia (10^{-3} kgm ²)	J_{total}	0.07	0.08	0.14	0.15	0.23	0.26	0.65	0.67	2.5	3.2	4.5	5.4	8.5	10.5	17.3	19.6	24.3	49.2		
Hub material (standard) (Steel on request)		Al		Al		Al		Al		steel		steel		steel		steel		steel		steel	
Approx. weight (kg)		0.15		0.3		0.4		0.8		1.7		2.5		4		7.5		7		12	
Torsional stiffness (10^3 Nm/rad)	C_T	20	15	39	28	76	55	129	85	175	110	191	140	450	350	510	500	780	1304		
axial	Max. values	1	2	1	2	1.5	2	2	3	2	3	2	3	2.5	3.5	2.5	3.5	3.5	3.5		
lateral		0.15	0.2	0.2	0.25	0.2	0.25	0.2	0.25	0.2	0.25	0.25	0.3	0.25	0.3	0.3	0.35	0.35	0.35		
axial spring stiffness (N/mm)	C_a	25	15	50	30	72	48	48	32	82	52	90	60	105	71	70	48	100	320		
lateral spring stiffness (N/mm)	C_r	475	137	900	270	1200	420	920	290	1550	435	2040	610	3750	1050	2500	840	2000	3600		

(1Nm \approx 8.85 in lbs) max. angular misalignment see BK 1 * two screws each hub, 180° apart



MODEL BKH

TECHNICAL SPECIFICATIONS

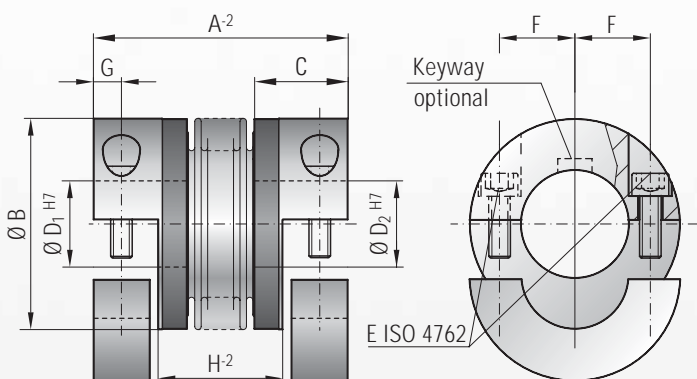

Properties:

- easy to mount
- suited for space restricted installations
- low moment of inertia

Material:

Bellows made of highly flexible high-grade stainless steel, hub material: see table below

Design:

Both clamping hubs are completely removable, due to split hubs and two radial screws ISO 4762 on each hub. Any imbalance of the clamping hubs is compensated with balancing bores located on the inside of the hub.

Temperature range:

-30 to +120° C (3.6 F - 270 F)

Speeds:

Up to 10,000 rpm, in excess of 10,000 with a finely balanced version.

Service life:

These couplings are maintenance-free if the technical limits are not exceeded.

Backlash:

Absolutely backlash-free due to frictional clamped connection.

Brief overloads:

Acceptable up to 1.5 times the value specified.

Tolerance:

On the hub/shaft connection 0.01 to 0.05 mm

Non-standard application:

Custom designs with varied tolerances, keyways, non-standard material and bellows are available upon request.

Ordering example

BKH / 80 / 94 / 20 / 22 / XX

Model
Series / Nm
Overall length
Ø D1 H7
Ø D2 H7
Non standard e.g. stainless steel

Model BK H	Series																					
	15		30		60		80		150		200		300		500		800		1500			
Rated torque (Nm)	T_{KN}		15		30		60		80		150		200		300		500		800		1500	
Overall length (mm)	A		59 66		69 77		83 93		94 106		95 107		105 117		111 125		133 146		140 166			
Outer diameter (mm)	B		49		55		66		81		81		90		110		124		134		157	
Fit length (mm)	C		22		27		31		36		36		41		43		51		45		55	
Inner diameter possible from Ø to Ø H7 (mm)	$D_{1/2}$		8-28		10-30		12-32		14-42		19-42		22-45		24-60		35-60		40-75		50-80	
ISO 4762 fastening screw	E		M5		M6		M8		M10		M10		M12		M12		M16		M16		M20	
Tightening torque of the fastening screw (Nm)	E		8		15		40		50		70		120		130		200		250		470	
Distance between centers (mm)	F		17		19		23		27		27		31		39		41		48		55	
(mm)	G		6.5		7.5		9.5		11		11		12.5		13		16.5		18		22.5	
Distance (mm)	H		29 36		35 43		41 51		47 59		48 60		51 63		55 69		62 75		65.5		71	
Moment of inertia (10 ⁻³ kgm ²)	J_{total}		0.07 0.08		0.14 0.15		0.23 0.26		0.65 0.67		2.5 3.2		4.5 5.4		8.5 10.5		17.3 19.6		24.3		49.2	
Hub material (standard) (steel on request)			Al		Al		Al		Al		steel		steel		steel		steel		steel		steel	
Approx. weight (kg)			0.15		0.3		0.4		0.8		1.7		2.5		4		7.5		7		12	
Torsional stiffness (10 ³ Nm/rad)	C_T		20 15		39 28		76 55		129 85		175 110		191 140		450 350		510 500		780		1304	
axial (mm)	Max. values		1 2		1 2		1.5 2		2 3		2 3		2 3		2.5 3.5		2.5 3.5		3.5		3.5	
lateral (mm)	Max. values		0.15 0.2		0.2 0.25		0.2 0.25		0.2 0.25		0.2 0.25		0.25 0.3		0.25 0.3		0.3 0.35		0.35		0.35	
axial spring stiffness (N/mm)	C_a		25 15		50 30		72 48		48 32		82 52		90 60		105 71		70 48		100		320	
lateral spring stiffness (N/mm)	C_r		475 137		900 270		1200 420		920 290		1550 435		2040 610		3750 1050		2500 840		2000		3600	

(1Nm ≈ 8.85 in lbs) max. angular misalignment see BK 1



MODEL BK3

TECHNICAL SPECIFICATIONS

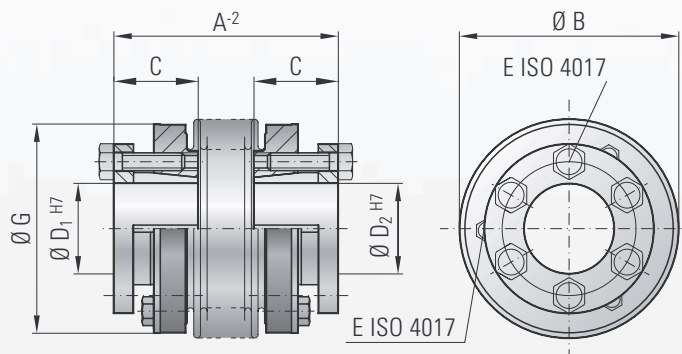

Properties:

- high clamping forces
- high degree of operating dependability
- new draw off device suited for space restricted installations

Material:

Bellows made of highly flexible high-grade stainless steel, the hub material is steel.

Design:

With tapered conical sleeves and strong, captive ISO 4017 draw-off screws.

Temperature range:

-30 to +120° C (3.6 F - 270 F)

Speeds:

Up to 10,000 rpm, in excess of 10,000 with a finely balanced version.

Service life:

These couplings are maintenance-free if the technical limits are not exceeded.

Backlash:

Absolutely backlash-free due to frictional clamped connection.

Brief overloads:

Acceptable up to 1.5 times the value specified.

Tolerance:

On the hub/shaft connection 0.01 to 0.05 mm

Non-standard application:

Custom designs with varied tolerances, keyways, non-standard material and bellows are available upon request.

Ordering example

BK3 / 60 / 76 / 20 / 22 / XX

- Model
- Series / Nm
- Overall length
- Ø D1 H7
- Ø D2 H7
- Non standard e.g. stainless steel

Model BK 3		Series																							
		15		30		60		150		200		300		500		800		1500		4000		6000		10000	
Rated torque (Nm)	T _{KN}	15		30		60		150		200		300		500		800		1500		4000		6000		10000	
Overall length (mm)	A	48	55	57	65	66	76	75	87	78	90	89	103	97	110	114	141	195	210	217					
Outer diameter of bellows (mm)	B	49		55		66		81		90		110		124		133		157		200		253		303	
Fit length (mm)	C	19		22		27		32		32		41		41		50		61		80		85		92	
Inner diameter from Ø to Ø H7 (mm)	D	10-22		12-23		12-29		15-38		15-44		24-56		24-60		30-60		35-70		50-100		60-140		70-180	
Fastening screws 6x	E	M4		M5		M5		M6		M6		M8		M8		M10		M12		M16		M16		8xM16	
Tightening torque of the fastening screws (Nm)		4		6		8		12		14		18		25		40		70		120		150		160	
ISO 4017 draw-off screw 3x	F	M4		M4		M5		M5		M6		M6		M6		M6		M8		M10		M10		4xM10	
Outer diameter of hub (mm)	G	49		55		66		81		90		110		122		116		145		175		246		295	
Moment of inertia (10 ⁻³ kgm ²)	J _{total}	0.12	0.59	0.3	0.34	0.54	0.73	1.2	1.6	1.7	2.5	5.1	5.9	9.1	9.9	13.2	34.9	85.5	254	629					
Approx. weight (kg)		0.25		0.4		0.8		1.2		1.8		3		4.2		5.6		8.2		23		32.6		45.5	
Torsional stiffness (10 ³ Nm/rad)	C _T	20	15	39	28	76	55	175	110	191	140	450	350	510	500	780	1304	3400	5700	10950					
axial (mm)	Max. values	1	2	1	2	1.5	2	2	3	2	3	2.5	3.5	2.5	3.5	3.5	3.5	3.5	3	3					
lateral (mm)		0.15	0.2	0.2	0.25	0.2	0.25	0.2	0.25	0.25	0.3	0.25	0.3	0.3	0.35	0.35	0.35	0.4	0.4	0.4					
axial spring stiffness (N/mm)	C _a	25	15	50	30	72	48	82	52	90	60	105	71	70	48	100	320	565	1030	985					
lateral spring stiffness (N/mm)	C _r	475	137	900	270	1200	420	1500	435	2040	610	3750	1050	2500	840	2000	3600	6070	19200	21800					

(1Nm ≅ 8.85 in lbs) max. angular misalignment see BK 1



MODEL BK4

TECHNICAL SPECIFICATIONS



for Fanuc-Motors

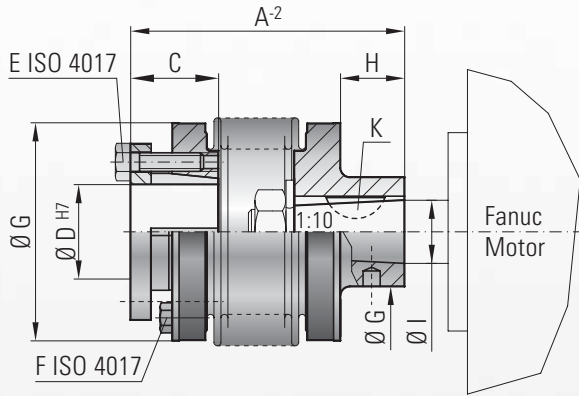

Ordering example

BK4 / 150 / 82 / 20 / XX

Model
Series / Nm
Overall length
Ø D H7
Non standard e.g. stainless steel

Properties:

- for conical shafts
- easy mounting and dismounting
- high degree of operating dependability

Material:

Bellows made of highly flexible high-grade stainless steel, the hub material is steel.

Design:

Spindle-side:
With conical sleeves and strong captive ISO 4017 draw-off screws

Motor-side:
Conical hub 1 : 10 and a keyway.

Temperature range:

-30 to +120° C (3.6 F - 270 F)

Speeds:

Up to 10,000 rpm, over 10,000 rpm with a finely balanced version.

Service life:

These couplings are maintenance-free if the technical limits are not exceeded.

Backlash:

Absolutely backlash-free due to frictional clamped connection.

Brief overloads:

Acceptable up to 1.5 times the value specified.

Tolerance:

On the hub/shaft connection 0.01 to 0.05 mm

Custom Designs:

With varied tolerances, keyways, non-standard material, and bellows are available upon request.

Technical instructions:

Before mounting the coupling, the conical sleeve (1) has to be removed. After sliding the coupling on to the motor shaft (3) the nut (4) can be put on through the bellowsbody (4).

To tighten the nut a special key DIN 896 B is used. The boring (5) is used for holding while tightening the nut.

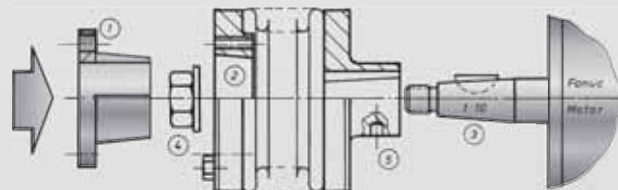

Key DIN 896 B

Model BK 4		Series							
		15		30		60		150	
Rated torque (Nm)	T_{KN}	15		30		60		150	
Overall length (mm)	A	47	54	68	76	72	82	82	94
Outer diameter of bellows (mm)	B	49		55		66		81	
Fit length (mm)	C	19		22		27		32	
Inner diameter from Ø to Ø H7 (mm)	D	10-22		12-23		12-29		15-37	
Fastening screws 6x		M4		M5		M5		M6	
Tightening torque of the fastening screws (Nm)	E	4		6		8		12	
DIN 933 draw-off screw 3x	F	M4		M4		M5		M5	
Shaft diameter (mm)	G	20		27		30		30	
Shaft length (mm)	H	8.5		22		18		20	
Moment of inertia (10^{-3} kgm ²)	J_{total}	0.10	0.12	0.22	0.27	0.58	0.61	1.1	1.4
Approx. weight (kg)		0.25		0.4		0.8		1.35	
Torsional stiffness (10^3 Nm/rad)	C_T	20	15	39	28	76	55	175	110
axial	Max. values	1	2	1	2	1.5	2	2	3
lateral	values	0.15	0.2	0.2	0.25	0.2	0.25	0.2	0.25
axial spring stiffness (N/mm)	C_a	25	15	50	30	72	48	82	52
lateral spring stiffness (N/mm)	C_r	475	137	900	270	1200	420	1500	435
cone Ø (Fanuc Motor) (mm)	I	11		16		16		16	
Keyway wide (mm)	K	4		5		5		5	

(1Nm \approx 8.85 in lbs) Higher torques on request max. angular misalignment see BK 1



MODEL BK5

TECHNICAL SPECIFICATIONS

Press-fit precision metal bellows couplings

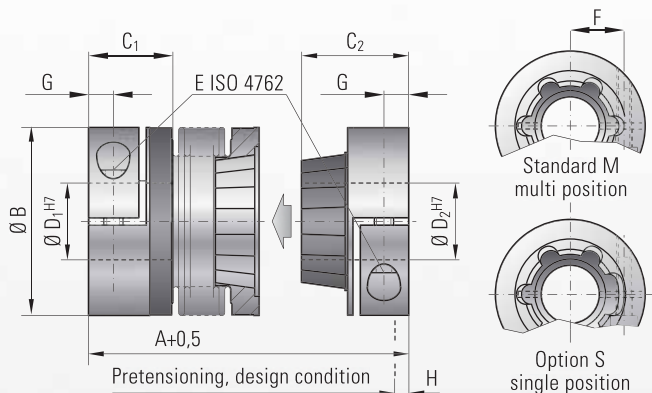

Properties:

Design details BK 5 / BK 6

- absolutely backlash-free and torsionally stiff
- easy mounting and dismantling
- electrically and thermally insulated
- wear-free and maintenance-free
- low moment of inertia
- compensation for misalignment

Temperature range:

-30 to +120° C (3.6 F - 270 F)

Speeds:

Up to 10,000 rpm, over 10,000 rpm with a finely balanced version.

Service life:

These couplings have an infinite life and are maintenance-free if the technical specifications are not exceeded.

Backlash:

Absolutely backlash-free due to frictional clamped connection and axial pretensioning of the tapered press-fit segments.

Brief overloads:

Acceptable up to 1.5 times the value specified.

Tolerance:

On the hub/shaft connection 0.01 to 0.05 mm

Material BK 5:

Bellows made of highly flexible, high-grade stainless steel: clamping hubs up to series 80 aluminium 150 and up steel. Tapered segment on hub face: glass-fiber reinforced plastic sprayed onto an aluminium hub.

Design BK 5:

One side with a single radial clamping screw ISO 4762. One side includes backlash-free clamping hub and tapered press-fit device. Any imbalance of the clamping hub, is compensated with balancing bores located on the inside of the hub.

Ordering example BK 5 / BK 6

BK5 / 30 / 71 / 18 / 19 / XX

Model
Series / Nm
Overall length
Ø D1 H7
Ø D2 H7
Non standard e.g. stainless steel

Model BK 5		Series																	
		15		30		60		80		150		300		500		800		1500	
Rated torque (Nm)	T_{KN}	15		30		60		80		150		300		500		800		1500	
Overall length (inserted) (mm)	A	60	67	71	79	85	95	94	106	95	107	114	128	136	149	150	172		
Outer diameter (mm)	B	49		55		66		81		81		110		124		133		157	
Fit length (mm)	C_1	22		27		32		36		36		43		51		45		55	
Fit length (mm)	C_2	28		33		39		43		43		52		61		74		94	
Inner diameter from from Ø to Ø H7 (mm)	D_1	8-28		10-30		12-32		14-42		14-42		24-60		35-60		40-75		50-80	
Inner diameter from from Ø to Ø H7 (mm)	D_2	8-22		10-25		12-32		14-38		14-38		24-58		35-60		40-62		50-75	
ISO 4762 screw	E	M5		M6		M8		M10		M10		M12		M16		2xM16*		2xM20*	
Tightening torque (Nm)		8		15		40		50		70		130		200		250		470	
Distance between centers (mm)	F	17		19		23		27		27		39		41		2x48*		2x55*	
	G	6.5		7.5		9.5		11		11		13		16.5		18		22.5	
Pretensioning approx. (mm)	H	0.2 up to 1.0		0.5 up to 1.0		0.5 up to 1.5		0.5 up to 1.5		0.5 up to 1.5		0.5 up to 1.5		1.0 up to 2.0		1.0 up to 2.5		1.0 up to 2.5	
Axial recovery force of coupling max. (N)		20	12	50	30	70	45	48	32	82	52	157	106	140	96	200	650		
Mass moment of inertia (10^{-3} kgm ²)	J_{total}	0.07	0.08	0.14	0.15	0.23	0.26	0.65	0.67	2.2	2.4	7.4	7.9	13.7	14.4	26.2	51.4		
Approx. weight (kg)		0.1	0.1	0.3	0.3	0.4	0.4	0.9	0.9	1.8	1.8	4	4	6.5	6.7	8.2	15.3		
Torsional stiffness (10^3 Nm/rad)	C_T	10	8	20	14	38	28	65	43	88	55	225	175	255	245	400	650		
axial* (mm)	Max. values	0.5	1	0.5	1	0.5	1	1	2	1	2	1.5	2	2.5	3.5	3	2		
lateral* (mm)		0.15	0.2	0.2	0.25	0.2	0.25	0.2	0.25	0.2	0.25	0.25	0.3	0.3	0.35	0.35	0.35		
Lateral spring stiffness (N/mm)	C_r	475	137	900	270	1200	420	920	290	1550	435	3750	1050	2500	840	2000	3600		

(1Nm \approx 8.85 in lbs)

* allowed following maximum pretensioning

* two screws each hub, 180° apart

Higher torques on request



MODEL BK6

TECHNICAL SPECIFICATIONS

Press-fit precision metal bellows couplings

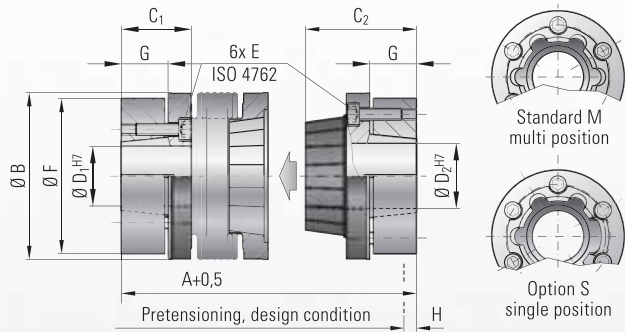

Material BK 6:

Bellows made of highly flexible, high-grade stainless steel; conical sleeves and tapered segment on bellows face are made of steel.

Tapered segment on hub face: glass-fiber reinforced plastic sprayed onto a steel hub.

Design BK 6:

One side conical sleeve with 6 fastening screws ISO 4762 and 3 draw-off threads. One side with backlash-free tapered conical sleeve with press-fit connection and 3 draw-off screws

axial mounting for space constrained applications

Design details BK 5 / BK 6

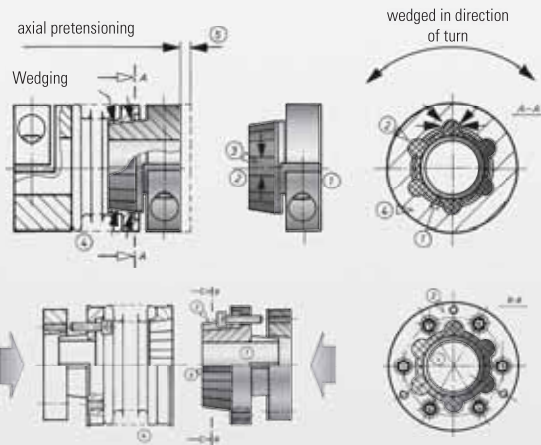

Due to the press-fit design the complete drive unit can be simply removed to the rear when servicing is required.

Six self-centering, tapered drive projections (2) have been formed into the plastic conical element, which has been molded onto an aluminium hub (1). The six axially arranged projections are configured conically in a longitudinal direction (3). The mating piece consists of a metal bellows with a tapered mounting (4). Absolutely backlash-free torque transmission is ensured due to the axial pretensioning (5) of the metal bellows during its mounting. This slight pretensioning has no negative influence on the operation of the metal bellows coupling or of the shaft bearing.

Material description of the plastic segment:

This is a glass-fiber reinforced plastic of the duromer group. With a glass-fiber content of 65% it achieves a strength roughly that of steel.

Model BK 6	Series																
	15		30		60		150		300		500		800		1500		
Rated torque (Nm)	T_{KN}		15	30	60	150	300	500	800	1500							
Overall length (inserted) (mm)	A		58	65	68	76	79	89	97	109	113	127	132	145	140	158	
Outer diameter (mm)	B		49	55	66	81	110	124	133	157							
Fit length (mm)	C_1		13.5	16.5	18	23.5	27	32	42	53							
Fit length (mm)	C_2		29	34	39	49.5	59	68	74	90.5							
Inner diameter from \emptyset to \emptyset H7 (mm)	D_1		10-22	12-24	12-32	15-40	24-56	30-60	40-62	50-75							
Inner diameter from \emptyset to \emptyset H7 (mm)	D_2		10-22	12-24	12-32	15-40	24-56	30-60	40-62	50-75							
ISO 4762 screw	E		M4	M5	M5	M6	M8	M8	M10	M12							
Tightening torque (Nm)	E		3.5	6.5	8	12	30	32	55	110							
Diameter of clamping cone (mm)	F		46.5	51	60	74	102	114	126	146							
	G		9.5	10.5	11.5	17.5	20	23	27	32							
Pretensioning approx. (mm)	H		0.2 up to 1.0	0.5 up to 1.0	0.5 up to 1.5	0.5 up to 1.5	0.5 up to 1.5	1.0 up to 2.0	1.0 up to 2.0	0.5 up to 1.5							
Axial recovery force of coupling max. (N)			20	12	50	30	70	45	82	52	157	106	140	96	400	650	
Moment of inertia (10^{-3} kgm ²)	J_{total}		0.1	0.12	0.2	0.25	0.4	0.45	2.0	2.5	5.4	6.1	8.4	9.1	19.5	44	
Approx. weight (kg)			0.3	0.32	0.5	0.52	0.82	0.84	1.6	1.7	4.1	4.2	6.0	6.3	9.4	16.2	
Torsional stiffness (10^{-3} Nm/rad)	C_T		10	8	20	14	38	28	88	55	225	175	255	245	400	660	
axial* (mm)	Max. values		0.5	1	0.5	1	0.5	1	1	2	1.5	2	2.5	3.5	3	2	
lateral (mm)	Max. values		0.15	0.2	0.2	0.25	0.2	0.25	0.2	0.25	0.25	0.3	0.3	0.35	0.35	0.35	
Lateral spring stiffness (N/mm)	C_r		475	137	900	270	1200	420	1550	435	3750	1050	2500	840	2000	3600	

(1Nm \approx 8.85 in lbs)

* allowed following maximum pretensioning

Higher torques on request.

Missing bellows values see BK1



MODEL BK7

TECHNICAL SPECIFICATIONS

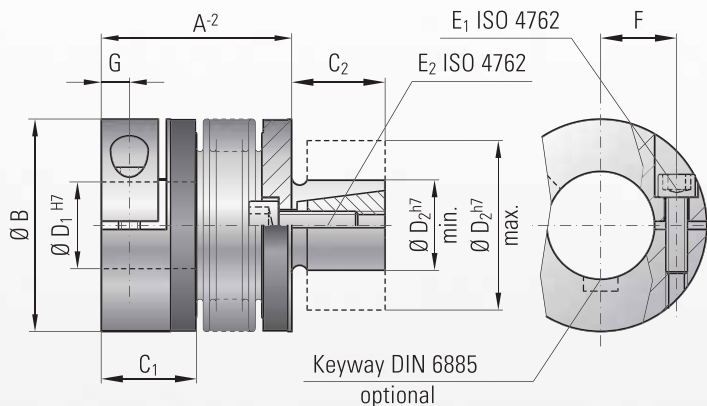

Properties:

- compact design, conserves space while saving cost
- easy mounting
- backlash-free and torsionally stiff
- low moment of inertia
- compensation of misalignment

Material:

Bellows made of highly flexible high-grade stainless steel, hub material: see in the table, Expanding hub and cone (steel).

Design:

On one side with a single radial clamping screw ISO 4762. On one side an expanding shaft with tapered clamping element.

Temperature range:

-30 to +120° C (3.6 F - 270 F)

Speeds:

Up to 10,000 rpm, over 10,000 rpm with a finely balanced version.

Service life:

These couplings have an infinite life and are maintenance-free if the technical specifications are not exceeded.

Backlash:

Absolutely backlash-free due to frictional clamped connection.

Brief overloads:

Acceptable up to 1.5 times the value specified.

Tolerance:

On the hub/shaft connection 0.01 to 0.05 mm

Custom Designs:

With varied tolerances, keyways, non-standard material, and bellows are available upon request.

Ordering example

BK7 / 150 / 71 / 32 / 35 / XX

Model
Series / Nm
Overall length
Ø D1 H7
Ø D2 h7
non standard

Model BK 7		Series				
		15	30	60	150	300
Rated torque (Nm)	T _{KN}	15	30	60	150	300
Overall length (inserted) (mm)	A	45 52	53 61	62 72	71 83	84 98
Outer diameter (mm)	B	49	55	66	81	110
Fit length (mm)	C ₁	22	27	32	36	43
Inner diameter from Ø to Ø H7 (mm)	D ₁	8-28	10-30	12-37	19-42	30-60
Fit length (mm)	C ₂	20	25	27	32	45
Shaft diameter from Ø to Ø h7 (mm)	D ₂	13-25	14-30	23-38	26-42	38-60
ISO 4762 fastening screw	E _{1/2}	M5	M6	M8	M10	M12
Tightening torque of the fastening screw (Nm)	E _{1/2}	8	14	38	65	120
Distance between centers (mm)	F	17	19	23	27	39
Distance (mm)	G	6.5	7.5	9.5	11	13
Moment of inertia (10 ⁻³ kgm ²)	J _{total}	0.07 0.08	0.14 0.15	0.23 0.26	2.2 2.4	6.5 8.9
Hub material (standard) (steel on request)		Al	Al	Al	Steel	Steel
Approx. weight (kg)		0.15	0.3	0.4	1.7	4
Torsional stiffness (10 ⁻³ Nm/rad)	C _T	20 15	39 28	76 55	175 110	450 350
axial (mm)	Max. values	1 2	1 2	1.5 2	2 3	2.5 3.5
lateral (mm)		0.15 0.2	0.2 0.25	0.2 0.25	0.2 0.25	0.25 0.3
axial spring stiffness (N/mm)	C _a	20 12	50 30	72 48	82 52	105 71
lateral spring stiffness (N/mm)	C _r	315 108	730 230	1200 380	1550 435	3750 1050

(1Nm ≈ 8.85 in lbs)

Max. angular misalignment 1 degree

Installation instructions:

By tightening the screw through the bellow body, the shaft is expanded. The coupling is designed for high dynamic hollowshaft connections eg. gear boxes. Recommended bore tolerance: ISO H7

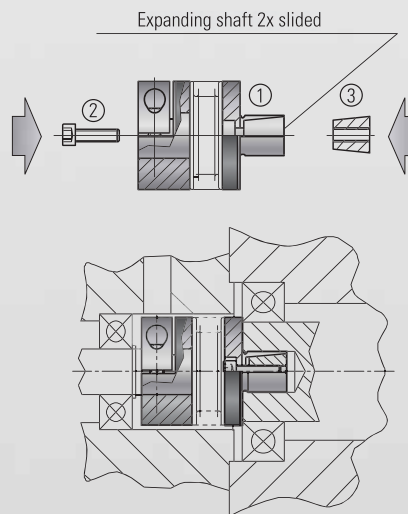



MODEL ATEX

FOR USE IN HAZARDOUS AREAS AND EXPLOSIVE ATMOSPHERE

AT mosphere EX possible

The ATEX 95 / ATEX 137 is regulated by the new European directive. Generally the explosive atmosphere is classified in 3 different zones.

Zone 0:

A place in which an explosive atmosphere is consisting out of a mixture of air and flammable substances in the form of gas, vapor or mist is present frequently, continuously or for longer periods.

Zone 20:

Is relevant for an explosive atmosphere in the form of clouds of combustible dust in air under the same conditions as above.

Zone 1:

Described as a place in which an explosive atmosphere is existing of a mixture of air and flammable substances in the form of gas, vapor or mist is likely to occur in normal operation occasionally.

Zone 21:

Is relevant for an explosive atmosphere in the form of clouds of combustible dust in air under the same conditions as above.

Zone 2:

A Place in which an explosive atmosphere is consisting out of mixture with air of flammable substances in the form of gas, vapor or mist is not likely to occur in normal operation but, if it does occur, it will persist for a short period only.

Zone 22:

Relevant for an explosive atmosphere in the form of a cloud of combustible dust in air under the same conditions as above.

For the classified zones 1/21 and 2/22 the metal bellows couplings BK-EEEx do have an accreditation according to ATEX 95/137

Mounting, Design:

Installation and Operation instructions:

Identification:

Example Accreditation data:

For security reasons all misalignment values and torque ratings are decreased by 20%

Installation and operating instructions are an essential part of the BK-EEEx metal bellows couplings.

Including the following facts:

- Design of the BK EEx metal bellows couplings
- Exact tightening torques and misalignment values
- How to put in operation
- Maintenance intervals
- Trouble shooting
- Marking of the coupling
- Declaration of conformity

All BK-EEEx couplings are permanent labeled to display manufacturer and accreditation data.



Type: BKL 150 EEx-2003
II 2 G D
EEx II c 40°C
Ser.No.: A 44305
Tech.Ref.No.:2003/003RW

Design of the BK-EEEx metal bellows couplings

All BK-EEEx metall bellows couplings are designed that neither sparking nor an increasing in excess of the allowable temperature at the surface can occur, even while malfunctions.

All dimensions of the standard models are retained. The coupling hubs are generally equipped with internal jaws for additional support of the bellows. If the bellows were to tear or break, the internal jaws would eliminate the risk of sparking or heating and continue to drive the load. In case of damage the angle of turn between the driving and the driven side is $\pm 4^\circ$ degrees . All hubs are made of steel or stainless steel materials only.

ATTENTION!

A monitoring of the driving- and driven face is required.

The shut off function has to take place immediately.

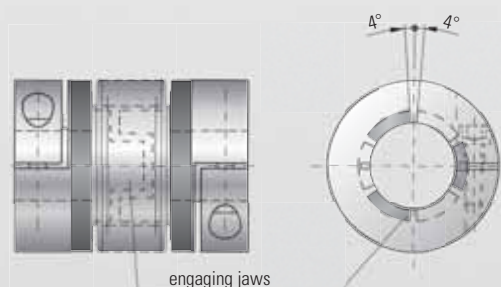



THE SELECTION

THE SELECTION PROCESS FOR TORSIONALLY STIFF METAL BELLOWS COUPLINGS

According to torque

In most cases couplings are rated according to the maximum peak torque to be regularly transmitted.

The peak torque may not exceed the rated torque of the coupling.

By rated torque we mean: the torque that is continuously transmittable within the specified acceptable speed and misalignment ranges.

The following calculation has proven itself to be a good rule of thumb:

$$T_{KN} \geq 1,5 \cdot T_{AS} \quad (\text{Nm})$$

T_{KN} = rated torque of coupling (Nm)

T_{AS} = peak torque of motor (Nm)

According to acceleration torques

For precise rating, the acceleration torque and moments of inertia of the entire machine have to be taken into consideration.

In the case of servo motors ensure that their acceleration or deceleration torque is greater than their torque by a multiple.

S_A = Shock or load factor

S_A = 1 (uniform load)

S_A = 2 (non-uniform load)

S_A = 3-4 (Shocking load)

Values for S_A = 2-3 are usual for servo drives on machine tools.

$$T_{KN} \geq T_{AS} \cdot S_A \cdot \frac{J_L}{J_A + J_L} \quad (\text{Nm})$$

T_{KN} = rated torque of coupling (Nm)

T_{AS} = max. acceleration torque on the drive face (Nm)

- or max. deceleration torque of the load face (Nm)

J_L = machine's moment of inertia (Spindle + slide + workpiece+ half of coupling) (kgm²)

J_A = motor's moment of inertia (kgm²)

According to resonance frequency

For the mech. substitutional model of the 2-mass-system is valid:

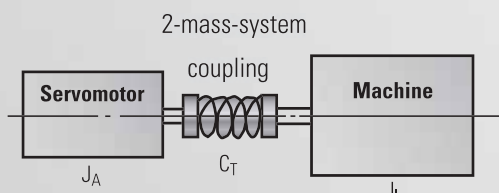

As a value of practise is valid: $f_e \geq 2 \times f_{er}$

$$f_e = \frac{1}{2 \cdot \pi} \sqrt{C_T \cdot \frac{J_A + J_L}{J_A \cdot J_L}} \quad (\text{Hz})$$

C_T = torsional stiffness of the coupling (Nm/rad)

f_e = resonance frequency of the 2 mass system (Hz)

f_{er} = frequency of the drive (Hz)

According to torsional stiffness

Transmission errors due to the torsional load:

$$\varphi = \frac{180}{\pi} \cdot \frac{T_{AS}}{C_T} \quad (\text{degrees})$$

φ = angle of turn (degrees)

C_T = torsional stiffness of coupling (Nm/rad)

T_{AS} = max. torque (Nm)



INSTALLATION INSTRUCTIONS

SERIES BK

Misalignments

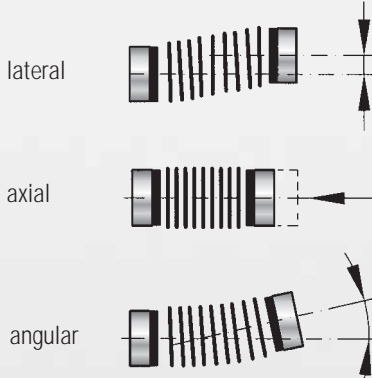

- When mounting the coupling ensure that the metal bellows are not damaged or bent.
- During mounting, the torque and axis misalignments may exceed 2 times the value specified without the operation of the coupling being restricted.
- However, for continuous operation, the axial and lateral misalignments specified in the catalog must not be exceeded. Only then the coupling will provide infinite performance.
- **Lateral axis misalignment requires special attention (see table values).**
- In the case of models BK 2/3/4/5/6 the tolerance between shaft/hub connection must not exceed 0.01 and 0.05 mm.
- Prior to mounting check for smooth running of the coupling hub on the shaft.
- Prior to mounting, make sure that the shaft is slightly oiled. Shaft keyways have no effect upon the function of the clamped connection.

Model BK 2 / BK 5 page 6 / page 10

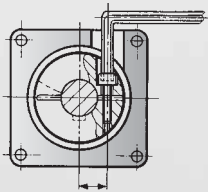

- The torque values of the fastening screws must be precisely applied in order to ensure secure clamping of the hubs.
- The dimensions for application of the mounting bore can be found under „F“ and „G“ in the table.
- No additional securing of the screw is necessary. Loosening of the fastening screws is sufficient to dismount the coupling.

Model BK 3 / BK 4 / BK 6 page 8 / page 9 / page 11

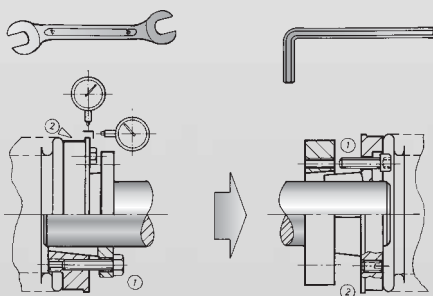

- It is absolutely essential that the fastening screws (1) are evenly tightened.
- Perform tightening of the fastening screws crosswise in order to avoid any distortion of the coupling hubs.
- Extraction of the tapered bushings for repair purposes is possible by means of 3x captive hexagonal draw-off screws (2).
- When dismounting assure during draw off that constant, synchronous unscrewing of the 3x hexagon screws is maintained.

The alignment surfaces on the outer faces of the hubs are for the purpose of checking hub distortion during mounting and for retromasurement of the misalignment of the axes.

Caution! An increase of tension on the tapered bushings is still achievable even after the screws have been tightened several times crosswise (max.3 times). This must be avoided without fail, otherwise destruction of the clamped connection may be the result.

Model BK 5 / BK 6 page 10 / page 11

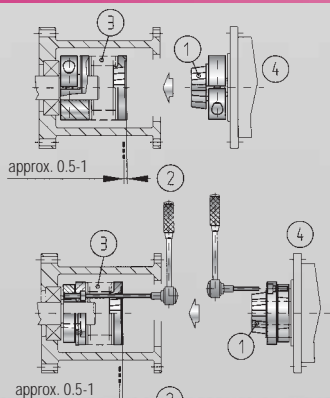

- The press-fit couplings do not need mounting holes on the intermediate flange. Model BK 6 will be mounted axial.
 - The six axially arranged projections (1) are configured conically in a longitudinal direction. Due to this a axial pretensioning (2) is needed.
The metal bellows (3) is used as a spring
 - Please maintain the pretensioning values which are printed in the table (page 8 + 9)
- Caution! When mounting the drive unit the pretensioning must be noticed.**



**Experience and
Know-how
for your special
requirements.**

R+W Antriebselemente GmbH
Alexander-Wiegand-Straße 8
D-63911 Klingenberg/Germany

Tel. +49-(0)9372 – 9864-0
Fax +49-(0)9372 – 9864-20

info@rw-kupplungen.de
www.rwcouplings.com

**QUALITY
MANAGEMENT**
We are certified
according to ISO 9001-200



TGA-ZM-05-91-00
Registration No. 9605022

The information mentioned in this document is based on our present knowledge and experiences and does not exclude the manufacturer's own substantial testing of the equipment. So this is no obligatory assurance even with regard to protection rights of Third Parties. The sale of our products is subject to our General Conditions of Sale and Delivery.



**TORQUE LIMITERS
Series SK**

From 0,1 – 2.800 Nm, Bore diameters 3 – 100 mm
Available as a single position, multi-position, load holding, or full disengagement version
Single piece or press-fit design



**BELLOWS COUPLINGS
Series BK**

From 15 – 10.000 Nm
Bore diameters 10 – 180 mm
Single piece or press-fit design



**BELLOWS COUPLINGS
ECONOMY CLASS
Series BKL**

From 2 – 500 Nm
Bore diameters 3 – 62 mm



**LINE SHAFTS
Series ZA/ZAe**

From 10 – 4.000 Nm
Bore diameters 10 – 100 mm
Available up to 6 mtr. length



**MINIATURE BELLOWS COUPLINGS
Series MK**

From 0,05 – 10 Nm
Bore diameters 1 – 28 mm
Single piece or press-fit design



**SERVOMAX®
ELASTOMER COUPLINGS
Series EK**

From 5 – 2.000 Nm, Shaft diameters 3 – 80 mm
backlash-free, press-fit design



**LINEAR COUPLINGS
Series LK**

From 70 – 2.000 N
Thread M5 – M16



**POLYAMID COUPLINGS
MICROFLEX
Series FK 1**

Rated torque 1 Ncm
Bore diameters 1 – 1,5 mm