



CAM CLUTCHES BREU SERIES



TSUBAKI EMERSON

- the working principle of lift-off Cam Clutches -

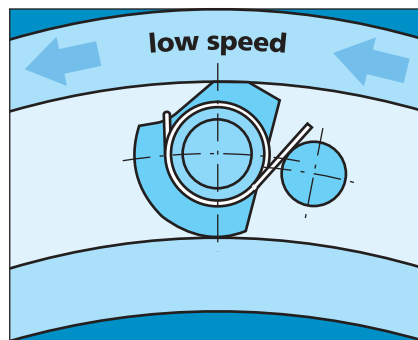
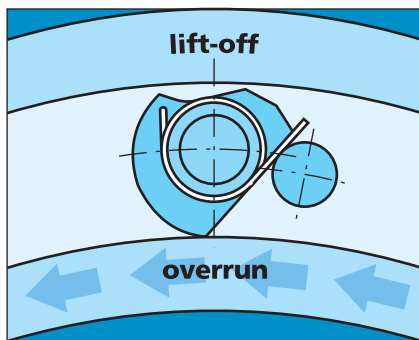
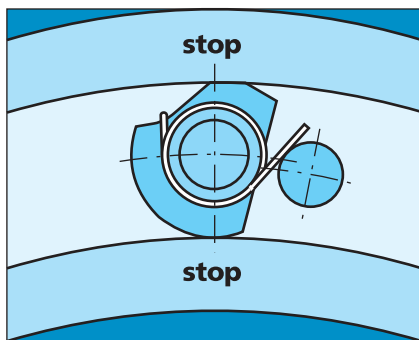

2

Cams of BREU series Cam Clutches are designed to "lift off", having no more contact with inner- and outer race when the clutch is overrunning. Loss of contact is caused by centrifugal force applied to all cams, having unbalanced weights due to their shape. This Cam Clutch has an excellent performance when used for overrunning at "high-speed inner race/low speed engaged outer race" features or when backstopping at "high speed inner race overrunning" features. The cams' lift off function warrantee a long wear life and thus BREU series Cam Clutches can be used in a wide



range of applications for many different types of machinery. BREU series Cam Clutches are modular components with flanges (E1, E2, E5 and E7), torque arms (E3) and covers (E4) as optional parts.

The cams engage between inner and outer race when the Cam Clutch is stationary. The clutch runs without contact of cams when the inner race (=load side) overruns at high speed. The cams are in contact with inner and outer race when the inner race (= load side) rotating speed slows down. At that moment the outer race drives the inner race at low rotation speed. Cams lose contact with outer and inner race when operating at a given minimum speed and a given maximum speed (see page 2), which ensures a long lifetime of the clutch.



- Cam Clutches BREU-series -

- basic models -



The basic model BREU Cam Clutch is available with and without (-K) keyway.

- capacities -

Model	Torque capacity	Inner race overrunning speed		Max. engagement
	N-m	Min. (r/min)	Max. (r/min)	Speed (r/min)
BREU 30	607	880	3,600	350
BREU 35	686	780	3,600	300
BREU 40	980	720	3,600	300
BREU 45	1,078	670	3,600	280
BREU 50	1,715	610	3,600	240
BREU 55	1,960	580	3,600	220
BREU 60	3,479	490	3,600	200
BREU 70	4,735	480	3,600	200
BREU 80	6,517	450	3,600	190
BREU 90	8,526	420	3,000	180
BREU100	14,210	460	2,500	180
BREU130	20,384	420	2,200	180
BREU150	33,908	370	1,300	180

- general information -

BREU series Cam Clutches are modular type one way clutches, supplied as a basic type clutch with standardized optional parts (E1, E2, E5 and E7 flanges, E3 torque arms and E4 covers).

The operational temperature range is -40°C up to +40°C.

All models are pre-greased at assembly.

Injection of an excessive quantity of grease to the bearings during maintenance will cause problems to the function of the cam clutch. It's springs cannot function properly any longer.

Tsubakimoto recommends a shaft tolerance of h7 with a standard key.

The keyways of all Tsubaki Cam Clutches are standardized according to DIN6885.1

Tsubakimoto recommends an H7 or H8 tolerance for dimensions B and E to re-work sprockets, gears, pulleys or other parts to be fitted.

- installation and usage -

1. Before assembly clean both surfaces of the outer race as well as the surface of the flange, cover, torque arm or other fitted part.
2. Verify the direction of rotation indicated with an arrow before fitting the optional parts.
3. When installing a sprocket, gear or other part, fix them with a hexagonal socket cap bolt.

4. When assembling optional parts in opposite position, the direction of rotation of the Cam Clutch can be changed.
5. Fix grease nipple and set screw to each operational part.
6. When mounting the clutch onto the shaft, apply pressure to the inner race but never to the outer race. Tap the inner race lightly with a soft hammer moving around the race circumference so the Cam Clutch moves slowly and uniformly onto the end of the shaft.
7. Do not use grease that contains EP additives.

- additional information -

For regularly updated information on Cam Clutches you are invited to visit: <http://www.tsubaki-emerson.co.jp>



- basic type Cam Clutches BREU-series -

4

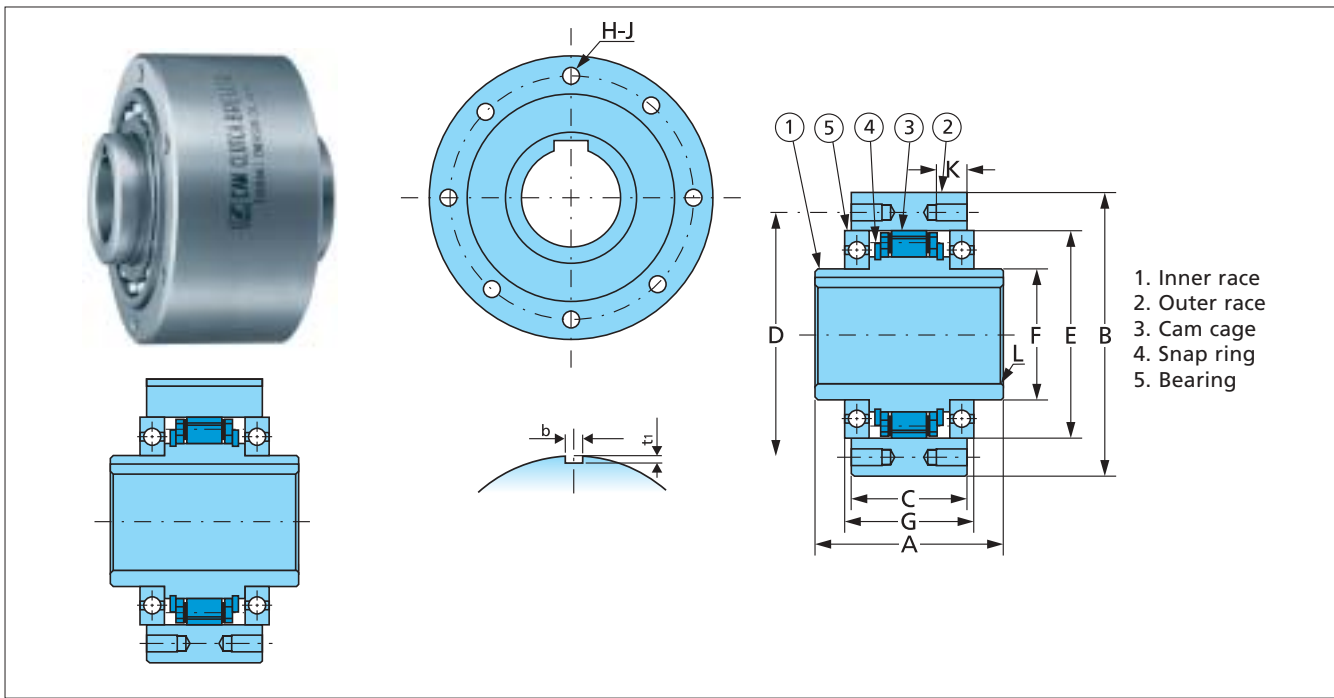

Basic type BREU Cam Clutch. Summary of parts and dimensions (referring to table below).

- dimensions and weight -

Model	Bore size	Keyway	A	B	C	D	E	F	G	H-J	K	L	b	t1	Weight kg
	H7			h7									P10		
BREU 30	30	8x3.3	76	100	51	87	75	45	56	6-M6	10	1.0	8	4.0	2.7
BREU 35	35	10x3.3	79	110	50	96	80	50	56	6-M6	12	1.0	10	5.0	3.2
BREU 40	40	12x3.3	86	125	53	108	90	55	59	6-M8	14	1.3	12	5.0	4.4
BREU 45	45	14x3.8	86	130	53	112	95	60	59	8-M8	14	1.3	14	5.5	4.7
BREU 50	50	14x3.8	94	150	64	132	110	70	72	8-M8	14	1.3	14	5.5	7.6
BREU 55	55	16x4.3	104	160	66	138	115	75	72	8-M10	16	1.5	16	6.0	8.9
BREU 60	60	18x4.4	120	170	84	150	125	80	95	10-M10	16	1.5	18	7.0	12.5
BREU 70	70	20x4.9	134	190	95	165	140	90	108	10-M10	16	1.8	20	7.5	17.2
BREU 80	80	22x5.4	144	210	100	185	160	105	108	10-M10	16	1.8	22	9.0	22.4
BREU 90	90	25x5.4	158	230	115	206	180	120	125	10-M12	20	2.0	25	9.0	30.3
BREU100	100	28x6.4	186	270	124	240	210	140	135	10-M16	24	2.0	28	10.0	45.5
BREU130	130	32x7.4	212	310	152	278	240	160	168	12-M16	24	2.5	32	11.0	67.0
BREU150	150	36x8.4	246	400	180	360	310	200	194	12-M20	32	2.5	36	12.0	145.0

- installation and usage -

1. When mounting the clutch onto the shaft, apply pressure to the inner race but never to the outer race. Tap the inner race lightly with a soft hammer moving around the race circumference so the Cam Clutch moves slowly and uniformly onto the end of the shaft.
2. The ambient temperature range is -40°C to +40°C.
3. All models are pre-greased.
4. Refer to page 2 for additional installation instructions and to page 10 for information on lubrication and maintenance.

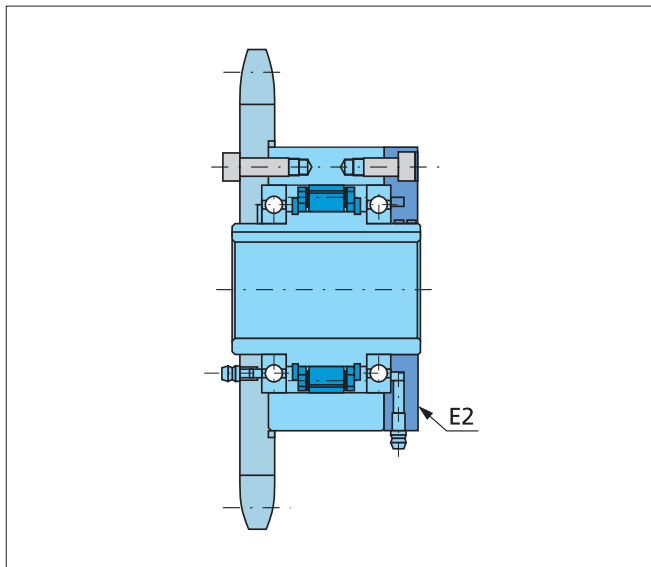

Installation example 1.

NOTE
Too much additional greasing of the bearings will cause malfunction of the Cam Clutch mechanism.

- Cam Clutches BREU-series with E1 and E2 flange -

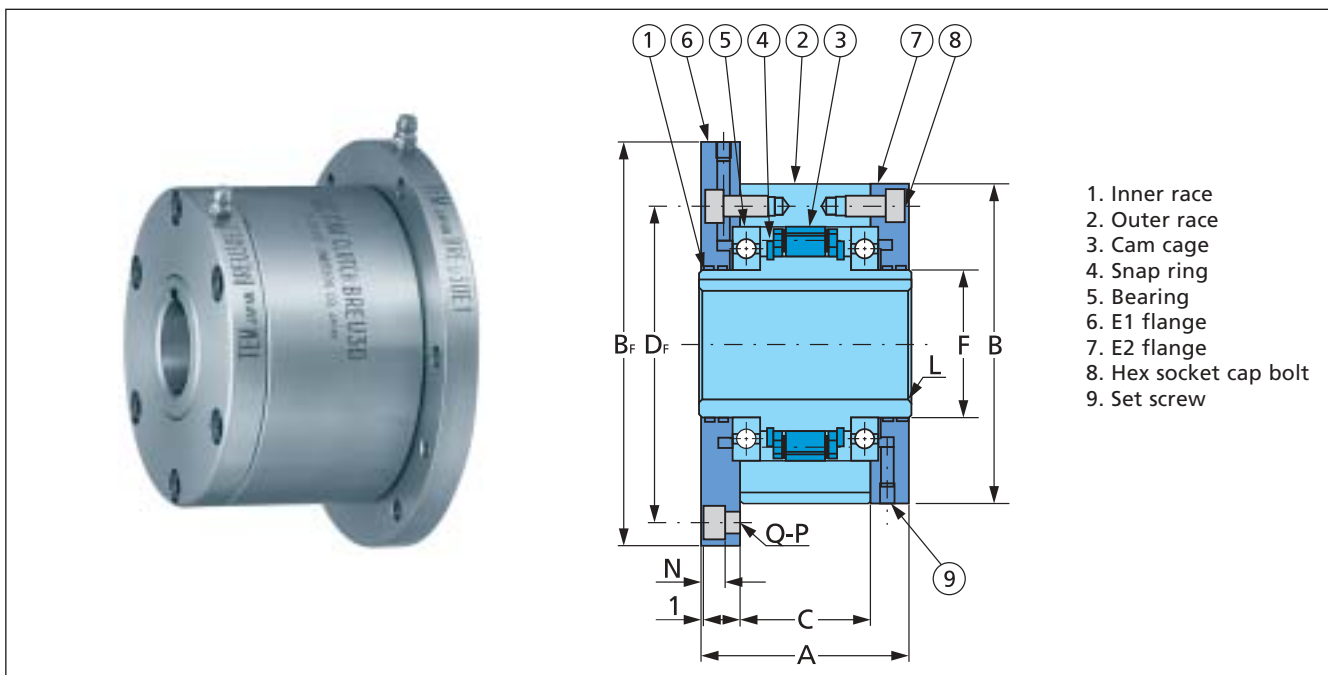

Basic type BREU Cam Clutch provided with an E1 and an E2 flange. Summary of parts and dimensions. (Referring to table below.)

- dimensions and weight -

Model	Bore size	Keyway	A	B	Bf	C	Df	F	L	M	N	Q-P	Weight kg
	H7			h7									
BREU 30 E1+E2	30	8×3.3	76	100	128	51	114	45	1.0	11.5	6.8	6-Ø 6.6	4.1
BREU 35 E1+E2	35	10×3.3	79	110	140	50	124	50	1.0	13.5	6.8	6-Ø 6.6	5.2
BREU 40 E1+E2	40	12×3.3	86	125	160	53	142	55	1.3	15.5	9.0	6-Ø 9.0	7.5
BREU 45 E1+E2	45	14×3.8	86	130	165	53	146	60	1.3	15.5	9.0	8-Ø 9.0	7.9
BREU 50 E1+E2	50	14×3.8	94	150	185	64	166	70	1.3	14.0	9.0	8-Ø 9.0	11.1
BREU 55 E1+E2	55	16×4.3	104	160	204	66	182	75	1.5	18.0	11.0	8-Ø 11.0	14.7
BREU 60 E1+E2	60	18×4.4	120	170	214	84	192	80	1.5	17.0	11.0	10-Ø 11.0	17.9
BREU 70 E1+E2	70	20×4.9	134	190	234	95	212	90	1.8	18.5	11.0	10-Ø 11.0	24.5
BREU 80 E1+E2	80	22×5.4	144	210	254	100	232	105	1.8	21.0	11.0	10-Ø 11.0	32.5
BREU 90 E1+E2	90	25×5.4	158	230	278	115	254	120	2.0	20.5	13.0	10-Ø 14.0	40.5
BREU100 E1+E2	100	28×6.4	186	270	335	124	305	140	2.0	30.0	17.5	10-Ø 18.0	68.0
BREU130 E1+E2	130	32×7.4	212	310	380	152	345	160	2.5	29.0	17.5	12-Ø 18.0	95.0
BREU150 E1+E2	150	36×8.4	246	400	485	180	445	200	2.5	32.0	21.5	12-Ø 22.0	197.0

- installation and usage -

1. By installing E1 flange and E2 flange in the opposite way, the direction of rotation can be changed.
2. When mounting the clutch onto the shaft, apply pressure to the inner race but never to the outer race. Tap the inner race lightly with a soft hammer moving around the race circumference so the Cam Clutch moves slowly and uniformly onto the end of the shaft.
3. All models are pre-greased.
4. Fix grease nipples to optional parts.
5. The ambient temperature range is -40°C to +40°C.
6. Refer to page 2 for additional installation instructions and to page 10 for information on lubrication and maintenance.

NOTE

Too much additional greasing of the bearings will cause malfunction of the Cam Clutch mechanism.

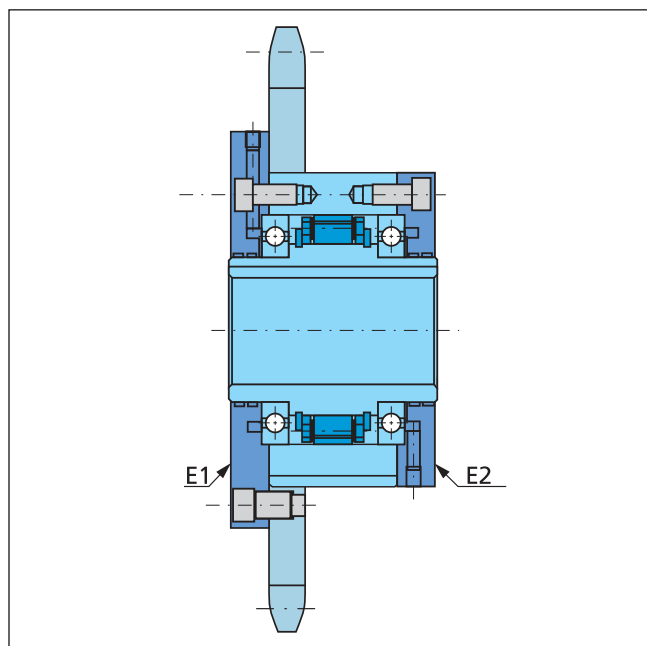

Installation example 2.

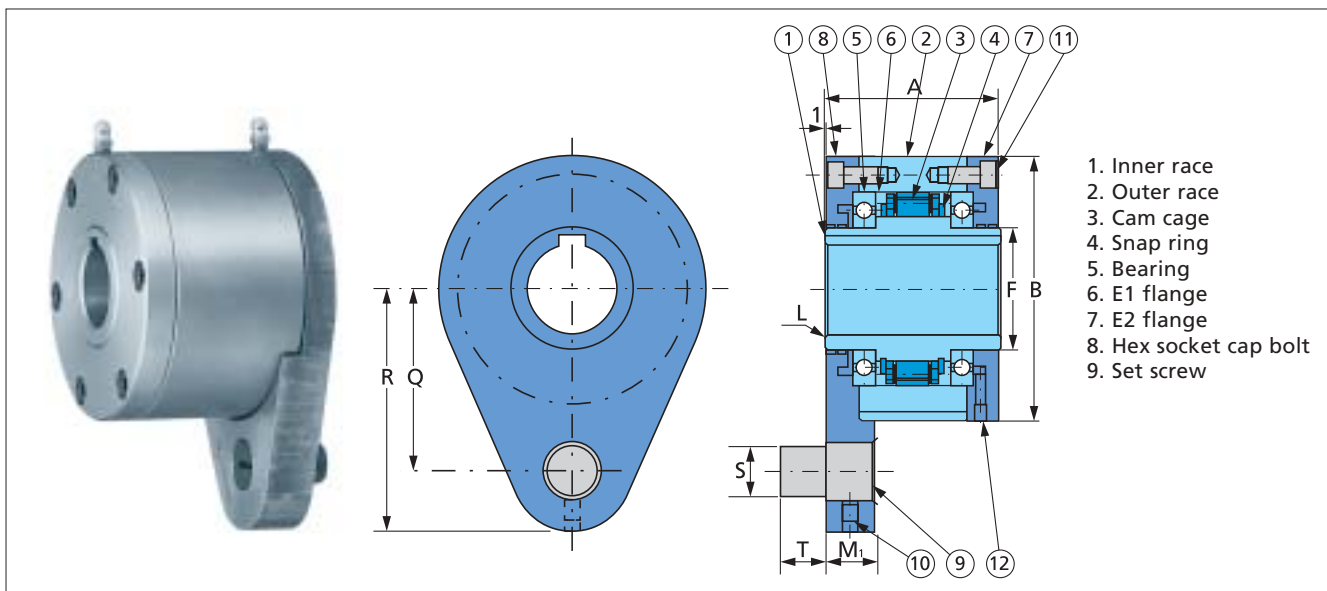

Basic type BREU Cam Clutch provided with an E2 flange and an E3 torque arm. Summary of parts and dimensions. (Referring to table below.)

- dimensions and weight -

Model	Bore size	Keyway	A	B	F	L	M1	Q	R	S	T	Weight
	H7			h7								kg
BREU 30 E2+E3	30	8×3.3	76	100	45	1.0	19	68	92	16	14	4.2
BREU 35 E2+E3	35	10×3.3	79	110	50	1.0	22	76	102	20	18	5.0
BREU 40 E2+E3	40	12×3.3	86	125	55	1.3	22	85	112	20	18	7.0
BREU 45 E2+E3	45	14×3.8	86	130	60	1.3	25	90	120	25	22	7.7
BREU 50 E2+E3	50	14×3.8	94	150	70	1.3	25	102	135	25	22	11.0
BREU 55 E2+E3	55	16×4.3	104	160	75	1.5	30	108	142	32	25	14.0
BREU 60 E2+E3	60	18×4.4	120	170	80	1.5	30	112	145	32	25	17.2
BREU 70 E2+E3	70	20×4.9	134	190	90	1.8	35	135	175	38	30	24.5
BREU 80 E2+E3	80	22×5.4	144	210	105	1.8	35	145	185	38	30	31.9
BREU 90 E2+E3	90	25×5.4	158	230	120	2.0	45	155	205	50	40	41.1
BREU100 E2+E3	100	28×6.4	186	270	140	2.0	45	180	230	50	40	65.0
BREU130 E2+E3	130	32×7.4	212	310	160	2.5	60	205	268	68	55	94.0
BREU150 E2+E3	150	36×8.4	246	400	200	2.5	60	255	325	68	55	190.0

- installation and usage -

1. By installing E2 flange and E3 torque arm in the opposite way, the direction of rotation can be changed.
2. When mounting the clutch onto the shaft, apply pressure to the inner race but never to the outer race. Tap the inner race lightly with a soft hammer moving around the race circumference so the Cam Clutch moves slowly and uniformly onto the end of the shaft.
3. All models are pre-greased.
4. Fix grease nipples to optional parts.
5. The ambient temperature range is -40°C to +40°C.
6. Refer to page 2 for additional installation instructions and to page 10 for information on lubrication and maintenance.

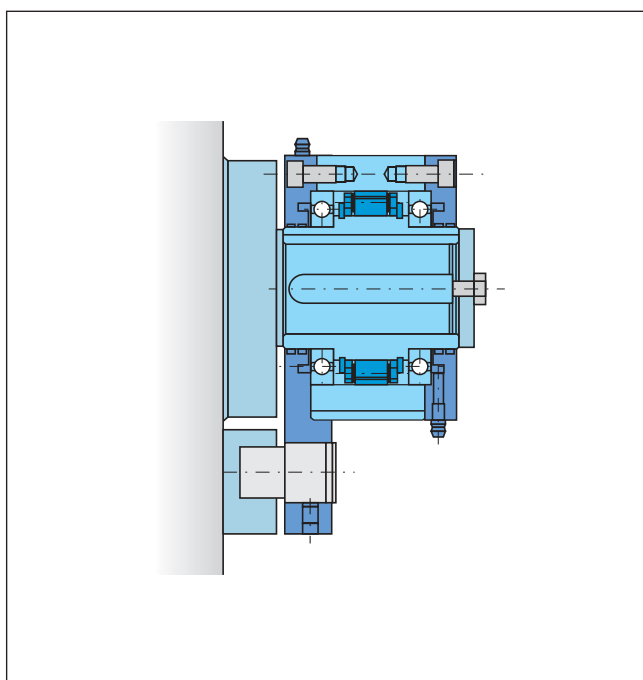

Installation example 3.

NOTE

Too much additional greasing of the bearings will cause malfunction of the Cam Clutch mechanism.

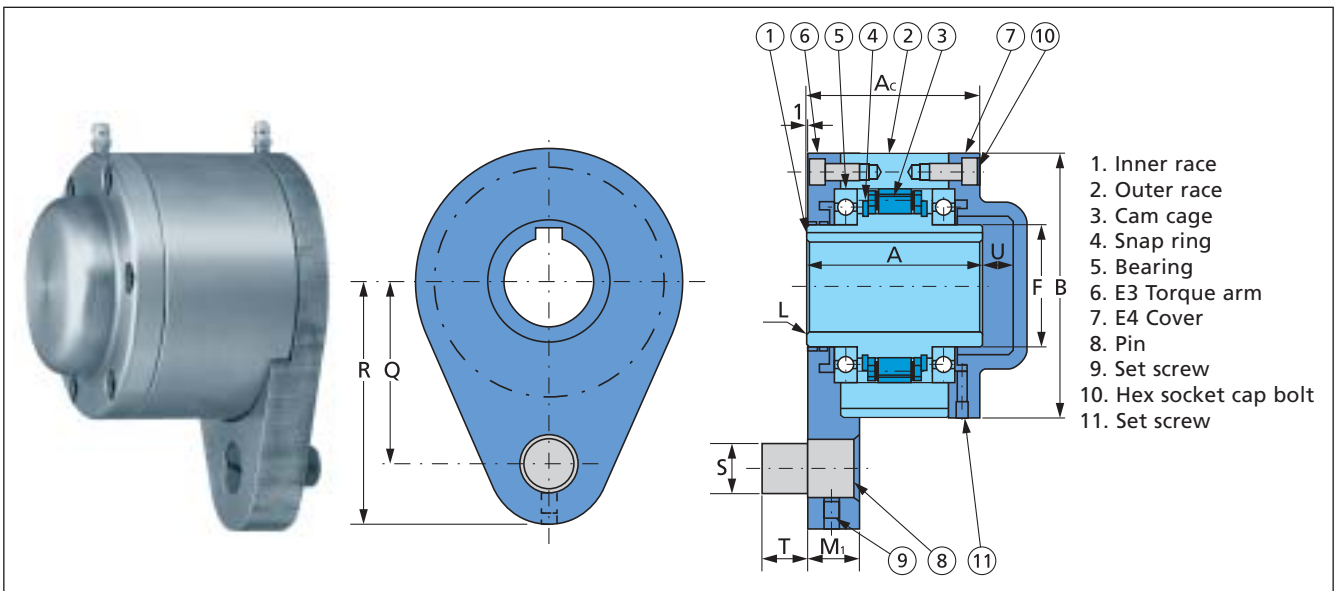

Basic type BREU Cam Clutch provided with an E3 torque arm and an E4 cover. Summary of parts and dimensions. (Referring to table below.)

- dimensions and weight -

Model	Bore size	Keyway	A	AC	B	F	L	M1	Q	R	S	T	U	Weight kg
	H7				h7									
BREU 30 E3+E4	30	8×3.3	76	92.0	100	45	1.0	19	68	92	16	14	10.0	4.5
BREU 35 E3+E4	35	10×3.3	79	97.0	110	50	1.0	22	76	102	20	18	12.0	5.3
BREU 40 E3+E4	40	12×3.3	86	105.0	125	55	1.3	22	85	112	20	18	12.0	7.4
BREU 45 E3+E4	45	14×3.8	86	108.0	130	60	1.3	25	90	120	25	22	15.0	8.1
BREU 50 E3+E4	50	14×3.8	94	113.0	150	70	1.3	25	102	135	25	22	12.0	11.5
BREU 55 E3+E4	55	16×4.3	104	126.0	160	75	1.5	30	108	142	32	25	15.0	15.6
BREU 60 E3+E4	60	18×4.4	120	143.0	170	80	1.5	30	112	145	32	25	15.0	18.0
BREU 70 E3+E4	70	20×4.9	134	164.5	190	90	1.8	35	135	175	38	30	22.5	25.5
BREU 80 E3+E4	80	22×5.4	144	168.0	210	105	1.8	35	145	185	38	30	16.0	32.9
BREU 90 E3+E4	90	25×5.4	158	192.0	230	120	2.0	45	155	205	50	40	27.0	43.4
BREU100 E3+E4	100	28×6.4	186	221.0	270	140	2.0	45	180	230	50	40	28.0	67.0
BREU130 E3+E4	130	32×7.4	212	250.0	310	160	2.5	60	205	268	68	55	30.0	97.0
BREU150 E3+E4	150	36×8.4	246	286.0	400	200	2.5	60	255	325	68	55	32.0	193.0

- installation and usage -

1. By installing the E3 torque arm and the E4 cover in the opposite way, the direction of rotation can be changed.
2. When mounting the clutch onto the shaft, apply pressure to the inner race but never to the outer race. Tap the inner race lightly with a soft hammer moving around the race circumference so the Cam Clutch moves slowly and uniformly onto the end of the shaft.
3. All models are pre-greased.
4. Fix grease nipples to optional parts.
5. The ambient temperature range is -40°C to +40°C.
6. Refer to page 2 for additional installation instructions and to page 10 for information on lubrication and maintenance.

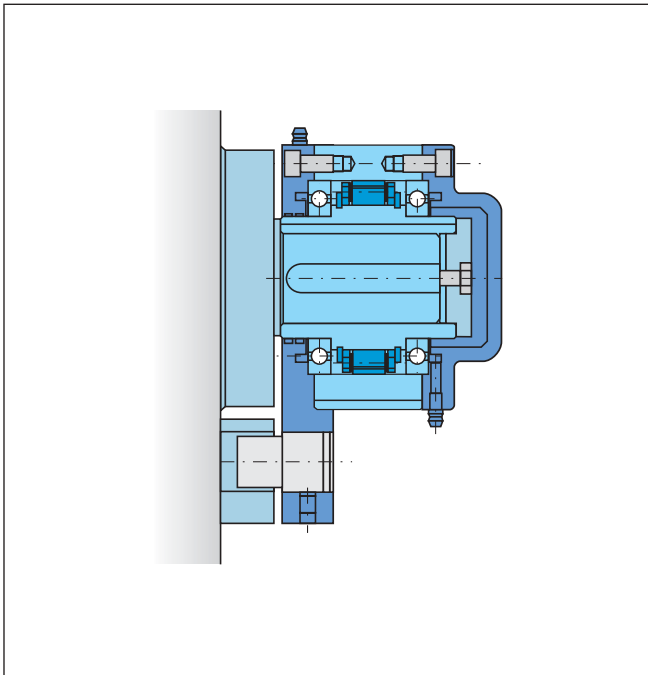

Installation example 4.

NOTE
 Too much additional greasing of the bearings will cause malfunction of the Cam Clutch mechanism.

- Cam Clutches BREU-series with E5 flange on both sides -

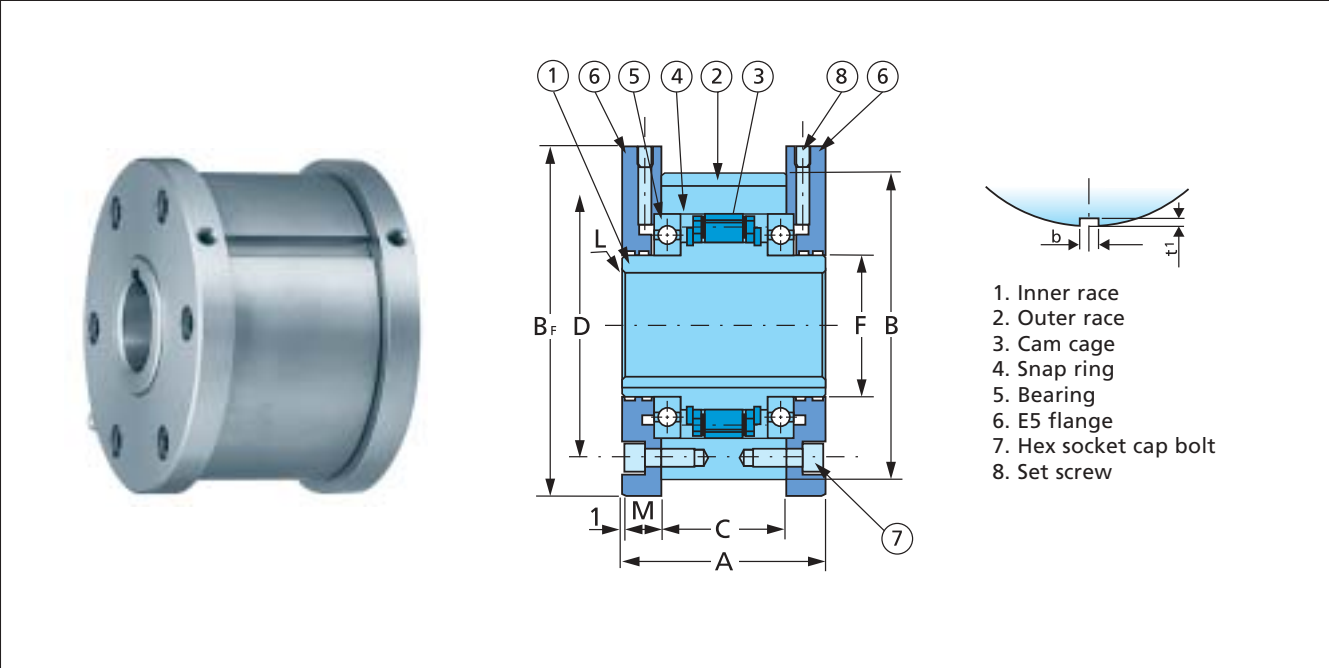

Basic type BREU Cam Clutch provided with an E5 flange on both sides. Summary of parts and dimensions. (Referring to table below.)

- dimensions and weight -

Model	Bore size	Keyway	A	B	B _f	C	D	F	L	M	b	t1	Weight kg
	H7			h7							P10		
BREU 30K E5+E5	30	8×3.3	76	100	109	51	87	45	1.0	11.5	8	4.0	3.9
BREU 35K E5+E5	35	10×3.3	79	110	119	50	96	50	1.0	13.5	10	5.0	4.9
BREU 40K E5+E5	40	12×3.3	86	125	135	53	108	55	1.3	15.5	12	5.0	7.0
BREU 45K E5+E5	45	14×3.8	86	130	140	53	112	60	1.3	15.5	14	5.5	7.4
BREU 50K E5+E5	50	14×3.8	94	150	160	64	132	70	1.3	14.0	14	5.5	10.7
BREU 55K E5+E5	55	16×4.3	104	160	170	66	138	75	1.5	18.0	16	6.0	13.6
BREU 60K E5+E5	60	18×4.4	120	170	182	84	150	80	1.5	17.0	18	7.0	17.3
BREU 70K E5+E5	70	20×4.9	134	190	202	95	165	90	1.8	18.5	20	7.5	23.5
BREU 80K E5+E5	80	22×5.4	144	210	222	100	185	105	1.8	21.0	22	9.0	31.3
BREU 90K E5+E5	90	25×5.4	158	230	242	115	206	120	2.0	20.5	25	9.0	38.4
BREU100K E5+E5	100	28×6.4	186	270	282	124	240	140	2.0	30.0	28	10.0	63.0
BREU130K E5+E5	130	32×7.4	212	310	322	152	278	160	2.5	29.0	32	11.0	88.0
BREU150K E5+E5	150	36×8.4	246	400	412	180	360	200	2.5	32.0	36	12.0	184.0

- installation and usage -

1. By turning the Cam Clutch the opposite way, the direction of rotation can be changed.
2. When mounting the clutch onto the shaft, apply pressure to the inner race but never to the outer race. Tap the inner race lightly with a soft hammer moving around the race circumference so the Cam Clutch moves slowly and uniformly onto the end of the shaft.
3. All models are pre-greased.
4. Fix grease nipples to optional parts.
5. The ambient temperature range is -40°C to +40°C.
6. Refer to page 2 for additional installation instructions and to page 10 for information on lubrication and maintenance.

NOTE
Too much additional greasing of the bearings will cause malfunction of the Cam Clutch mechanism.

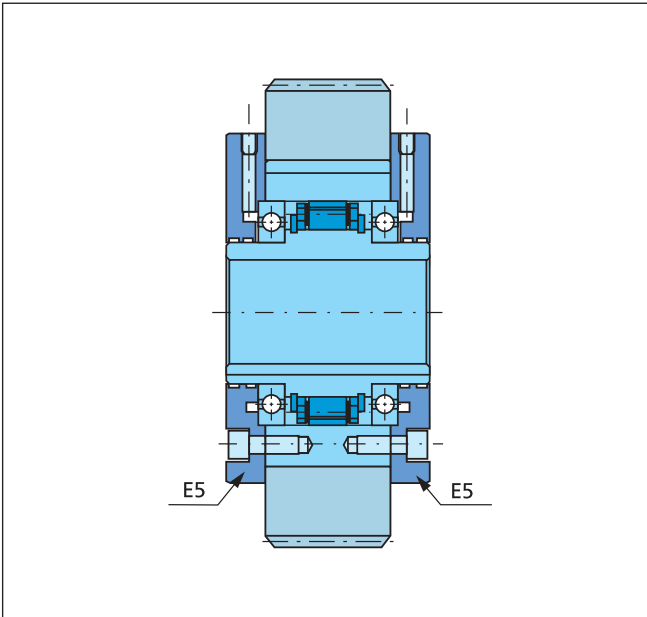

Installation example 5.

- Cam Clutches BREU-series with E2 and E7 flange -

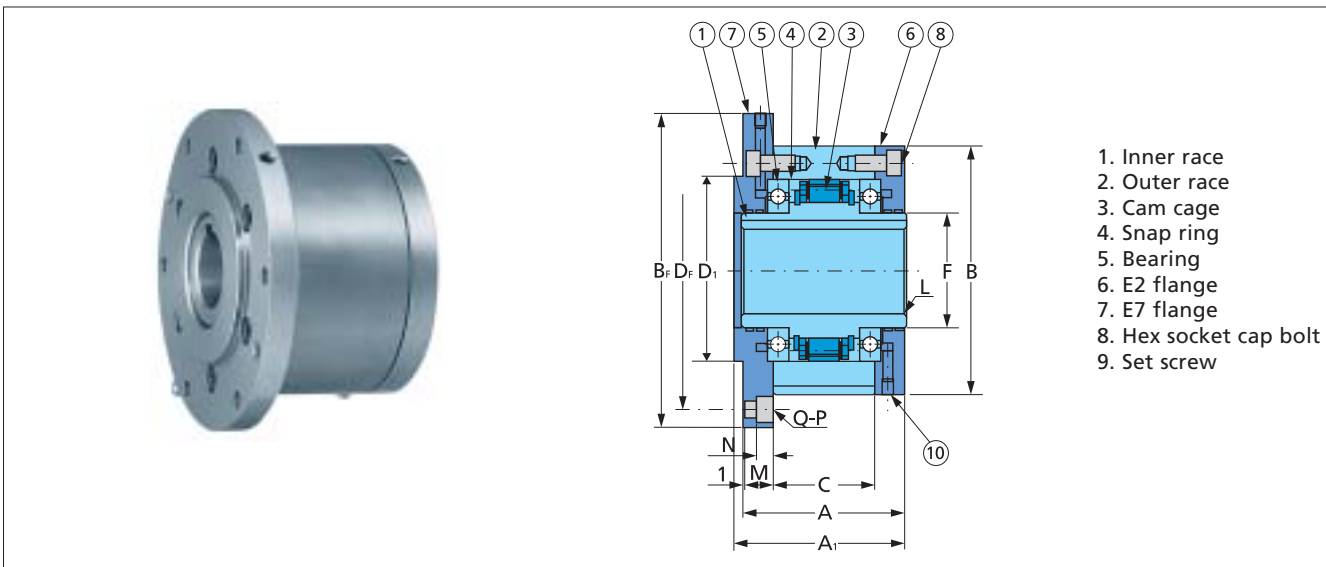

- 1. Inner race
- 2. Outer race
- 3. Cam cage
- 4. Snap ring
- 5. Bearing
- 6. E2 flange
- 7. E7 flange
- 8. Hex socket cap bolt
- 9. Set screw

Basic type BREU Cam Clutch provided with an E7 and an E2 flange. Summary of parts and dimensions. (Referring to table below.)

- dimensions and weight -

Model	Bore size	Keyway	A	A ₁	B	B _F	C	D ₁	DF	F	L	M	N	Q-P	Weight kg
	H7				h7			h7							
BREU 30 E2+E7	30	8×3.3	76	78	100	128	51	75	114	45	1.0	11.5	6.8	6-Ø 6.6	4.2
BREU 35 E2+E7	35	10×3.3	79	81	110	140	50	80	124	50	1.0	13.0	6.8	6-Ø 6.6	5.3
BREU 40 E2+E7	40	12×3.3	86	88	125	160	53	90	142	55	1.3	15.0	9.0	6-Ø 9.0	7.6
BREU 45 E2+E7	45	14×3.8	86	88	130	165	53	95	146	60	1.3	15.0	9.0	8-Ø 9.0	8.0
BREU 50 E2+E7	50	14×3.8	94	96	150	185	64	110	166	70	1.3	13.0	9.0	8-Ø 9.0	11.3
BREU 55 E2+E7	55	16×4.3	104	106	160	204	66	115	182	75	1.5	17.0	11.0	8-Ø 11	14.8
BREU 60 E2+E7	60	18×4.4	120	122	170	214	84	125	192	80	1.5	16.0	11.0	10-Ø 11	18.2
BREU 70 E2+E7	70	20×4.9	134	136	190	234	95	140	212	90	1.8	17.5	11.0	10-Ø 11	24.8
BREU 80 E2+E7	80	22×5.4	144	146	210	254	100	160	232	105	1.8	20.0	11.0	10-Ø 11	32.9
BREU 90 E2+E7	90	25×5.4	158	160	230	278	115	180	254	120	2.0	19.0	13.0	10-Ø 14	40.8
BREU100 E2+E7	100	28×6.4	186	188	270	335	124	210	305	140	2.0	28.0	17.5	10-Ø 18	69.0
BREU130 E2+E7	130	32×7.4	212	214	310	380	152	240	345	160	2.5	27.0	17.5	12-Ø 18	96.0
BREU150 E2+E7	150	36×8.4	246	248	400	485	180	310	445	200	2.5	30.0	21.5	12-Ø 22	198.0

- installation and usage -

1. By installing E2 flange and E7 flange in the opposite way, the direction of rotation can be changed.
2. When mounting the clutch onto the shaft, apply pressure to the inner race but never to the outer race. Tap the inner race lightly with a soft hammer moving around the race circumference so the Cam Clutch moves slowly and uniformly onto the end of the shaft.
3. All models are pre-greased
4. Fix grease nipples to optional parts
5. The ambient temperature range is -40°C to +40°C.
6. Too much overhang load to the F7 flange will cause troublesome operation and damage the Cam Clutch mechanism. In cases where excessive overhang load is applied, Tsubaki recommends an additional bearing to be installed onto the fixed equipment on the correct centerline.
7. Refer to page 2 for additional installation instructions and to page 10 for information on lubrication and maintenance.

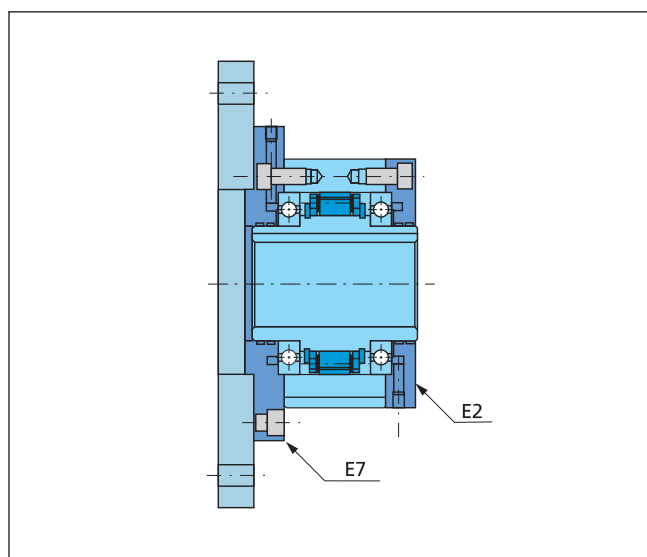

Installation example 6.

NOTE

Too much additional greasing of the bearings will cause malfunction of the Cam Clutch mechanism.

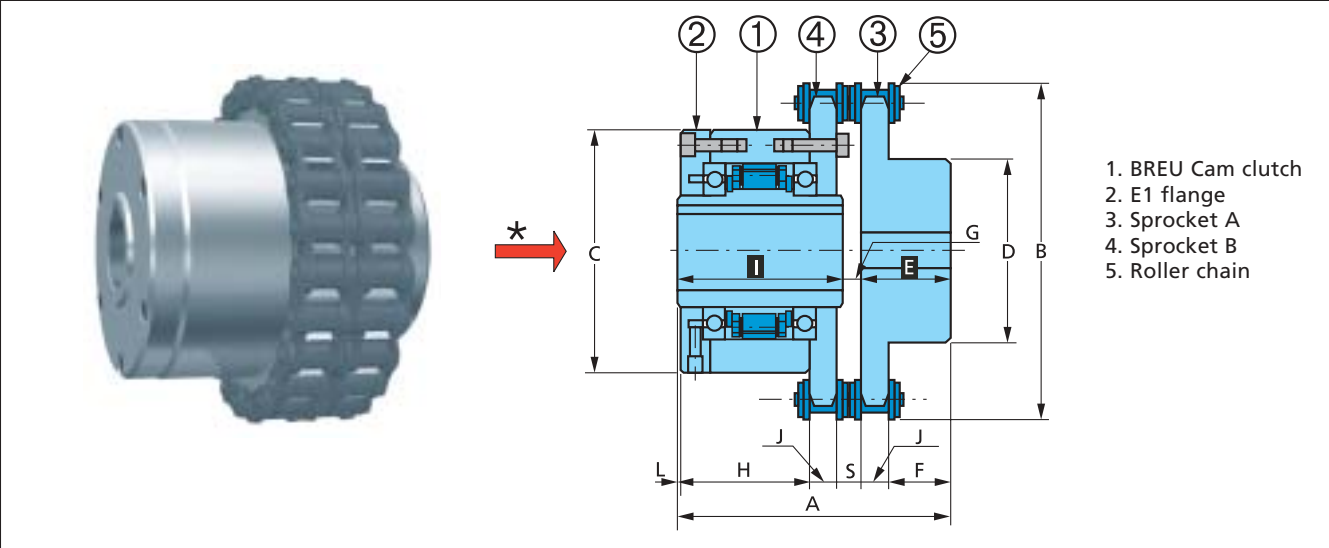

Summary of parts and dimensions (referring to table below).

- dimensions and weights -

Model	Bore size	Keyway	A	B	C	D	E	F	G	H	I	J	L	S	Weight
	H7				h7										kg
BREU 30-C	30	8x3.3	109.9	137	100	73	28	19.3	5.9	62.5	76	8.7	1	9.7	5.9
BREU 35-C	35	10x3.3	127.7	152	110	83	40	28.3	8.7	63.5	79	11.7	1	11.5	8.5
BREU 40-C	40	12x3.3	132.7	164	125	83	40	28.3	6.7	68.5	86	11.7	1	11.5	10.5
BREU 45-C	45	14x3.8	132.7	176	130	83	40	28.3	6.7	68.5	86	11.7	1	11.5	11.2
BREU 50-C	50	14x3.8	142.2	200	150	83	40	28.3	8.2	78.0	94	11.7	1	11.5	15.6
BREU 55-C	55	16x4.3	159.8	219	160	107	45	30.4	10.8	84.0	104	14.6	1	15.2	21.8
BREU 60-C	60	18x4.4	176.8	235	170	107	45	30.4	11.8	101.0	120	14.6	1	15.2	26.4
BREU 70-C	70	20x4.9	189.3	251	190	107	45	30.4	10.3	113.5	134	14.6	1	15.2	33.0
BREU 80-C	80	22x5.4	196.8	267	210	107	45	30.4	7.8	121.0	144	14.6	1	15.2	41.0

Model	Sprocket	Roller chain weight (kg)				Sprocket A type				CP total weight	Basic type	E2 flange	BREU-C
	weight (kg)	1 m (W)	length	total l.	weight	PCD	d	T	weight				weight
BREU 30-C	1.4	2.07	15.875	0.3810	0.788670	12.162	7.5	0.89	0.50272	2.691	2.7	0.473	5.864
BREU 35-C	2.5	3.04	19.05	0.4191	1.274064	13.386	8.0	1.19	0.84466	4.619	3.2	0.686	8.505
BREU 40-C	2.6	3.04	19.05	0.4572	1.389888	14.595	9.0	1.19	0.96807	4.958	4.4	1.076	10.434
BREU 45-C	2.7	3.04	19.05	0.4953	1.505712	15.804	9.5	1.19	1.16975	5.375	4.7	1.107	11.182
BREU 50-C	3.4	3.04	19.05	0.5715	1.737360	18.252	11.0	1.19	1.55561	6.693	7.6	1.268	15.561
BREU 55-C	5.4	5.27	25.40	0.6096	3.212592	19.460	11.5	1.50	2.27795	10.891	8.9	1.995	21.786
BREU 60-C	5.9	5.27	25.40	0.6604	3.480308	21.072	12.5	1.50	2.66005	12.040	12.5	1.829	26.369
BREU 70-C	6.5	5.27	25.40	0.7112	3.748024	22.686	14.0	1.50	2.94544	13.193	17.2	2.606	32.999
BREU 80-C	7.1	5.27	25.40	0.7620	4.015740	24.300	16.0	1.50	3.09182	14.208	22.4	3.752	40.360

- installation and usage -

- BREU-C Series Cam Clutch Couplings are a combination of BREU Cam Clutches equipped with a Tsubaki type Chain Couplings (without covers/casings).
- Firstly mount the Cam Clutch loosely onto the high-speed shaft.
- Accurately align both sprockets by checking with a straight edge on the teeth of both sprockets.
- Specify right hand (RH) or left hand (LH) as inner race overrunning direction from the view of the Cam Clutch side when ordering. See the above drawing (*).
- Use the same lubricant for the coupling chain as for Tsubaki roller chains.
- Ensure that the chain is properly installed. If using a spring type connecting link ensure the closed end of the spring clip is fitted in the same direction as the rotation of the outer race.

- lubrication -

BREU Series Cam Clutches need periodic maintenance and lubrication to both bearings providing the maximum performance throughout the Cam Clutch' service life.

The Cam Mechanism DOES NOT require any maintenance therefore never use an excessive quantity of grease, yet lack of prescribed maintenance and lubrication will shorten the Service Life of the Cam Clutch and may cause unnecessary mechanical damage.

Recommended grease for Cam Clutches of the BREU-series

Oil company	Ambient temperature	
	- 5° C ~ + 40° C	- 40° C ~ + 40° C
Esso	Beacon 2	Beacon 325
Mobil	Mobilux Grease No. 2	Mobil temp SHC 100
Shell	Alvaria Grease No. 2	Alvaria Grease RA
BP	Energrease LS2	Energrease LT2
Total	Multis 2	Aerogrease 22

Note: Do not use grease containing EP additives when selecting any other brand or make.

- maintenance -

BREU series Cam Clutches are pre-greased at the factory and the integrated bearings should be re-greased every three month after installation. Follow the procedures below.

Remove the setscrew at the flange, torque arm, cover or fitted part. Inject equal amounts of grease into both bearings via the grease nipples. Refer to the grease volume table for the correct amount.

Run the Cam Clutch disengaged for 20 to 30 minutes with setscrew removed. Excessive grease in the clutch area will flow out of the tapped holes.

Wipe off excessive grease and re-install the set screw.

Grease volume table

Model	Each bearing (g)	Model	Each bearing (g)
BREU 30	10	BREU 70	50
BREU 35	10	BREU 80	80
BREU 40	15	BREU 90	90
BREU 45	20	BREU100	160
BREU 50	30	BREU130	260
BREU 55	30	BREU150	460
BREU 60	40		

- warning -



Use with care to prevent injury



Comply with the following to avoid serious personal injury

1. Guards must be provided on all power transmission and conveyor applications in accordance with provisions of ANSI/ASME B 15.1 1992 and ANSI/ASME B 20.1 1993 or other applicable standards. When revisions of these standards are published, the updated edition shall apply.
2. Always lock out power switch before installing, removing, lubricating or servicing a system that uses Cam Clutch products.
3. If the Cam Clutch is used for repeated starting and stopping, make sure the strength of the supports for the Cam Clutch are sufficient.
4. The capacity of your Cam Clutch may be effected by the accuracy of its set up, the amount of pressure exerted on it, wear on other parts in your system, or wear life of the Cam Clutch itself. Check the Cam Clutch at regular intervals and observe any necessary safety precautions.
5. When connecting or disconnecting Cam Clutch products, eye protection is required. Wear safety glasses, protective clothing, gloves and safety shoes.

Tsubaki Emerson developed many series of Cam Clutches to meet any industrial demand. Except for the series mentioned in this brochure you may need additional technical solutions to comply with your specific application. The bro-

chures shown below may give you an impression of the vast range of Cam Clutches we can deliver from stock and on customer specifications. Please do not hesitate to contact us for advice or further information.

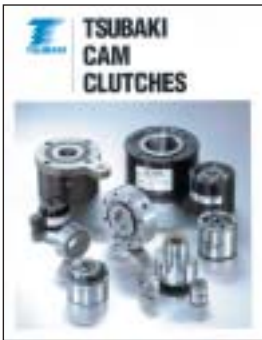

Tsubaki Emerson Cam Clutches are precision devices which lock the inner and outer races through the wedging action of cams to transmit torque in one direction of rotation and overrun in the opposite direction.

These units are often referred to as freewheels, sprag, overrunning, backstop, or one-way clutches, depending upon their application. In this brochure you will find the complete range of Cam Clutches according to Japanese and American standards.

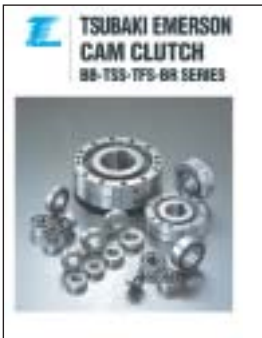

BB (build-in bearing) series Cam Clutches are available with and without keyways on inner race and/or outer race. Moreover the 2GD versions have special lip seals for effective protection against dust.

6200 series ball bearings, having keyway on the inner race as standard.

TSS series are non-bearing supported Cam Clutches and as BB series, dimensionally identical to

TFS series are similar to TSS, however their dimensions are the same as 6300 series bearings.

Both TSS and TFS series do require regular maintenance and lubrication as well as lateral bearing support.

BR series Cam Clutches are designed for backstop and overrunning applications with high speeds, having lift off designed cams ensuring a longer lifetime than any other type of clutch.

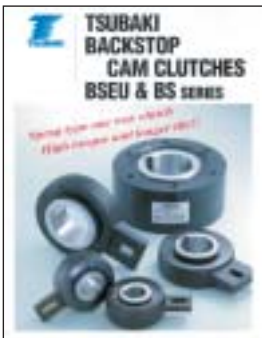

These series of Cam Clutches from Tsubaki Emerson are one-way clutches with the safest rotation prevention qualities available. They are manufactured for installations with low speed shaftrotations of inclined con-

veyors such as bucket and pivot elevators. Compared to other one-way clutches (ratchet or roller ramp clutch) similar in size, overheating during times when the motor is idling is significantly lower. This helps to maintain superb lubrication qualities thereby improving the wear life of the clutch. Extended fatigue life is also obtainable due to the clutch's large torque capacity.

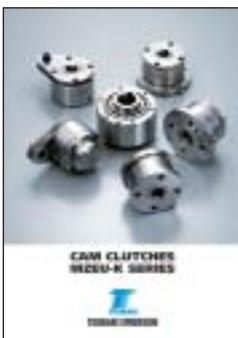

Tsubaki MZEU-K Cam Clutches are sprag type one-way clutches and leader in its class. The one-way clutch was developed originally as a ratchet clutch later to become a roller ramp clutch and finally became Tsubaki's Cam Clutch.

Tsubaki has a vast amount of experience producing this style of clutch and supplies them to many kinds of industry throughout the world.

The Tsubaki Cam Clutch ensures a longer life to the mechanism than any other type of one-way clutch.

MZEU- K series Cam Clutches are the most recent development of one-way clutches, based on historically proven European style clutches.

MZEU-K series Cam Clutches are modular type one way clutches, supplied as basic type clutch with standardized optional parts E1, E2, E5 & E7 flanges, E3 torque arm and E4 cover.

For more information please contact:

TSUBAKIMOTO EUROPE B.V. - Belder 1 - NL 4704 RK Roosendaal - the Netherlands
 Tel. +31 (0)165 59 48 00 - Fax +31 (0)165 54 94 50 - E-mail info@tsubaki.nl - Internet <http://tsubakimoto.com>

