

Positioning system DLSZ 120, 160, 200

Specifications

Belt drive

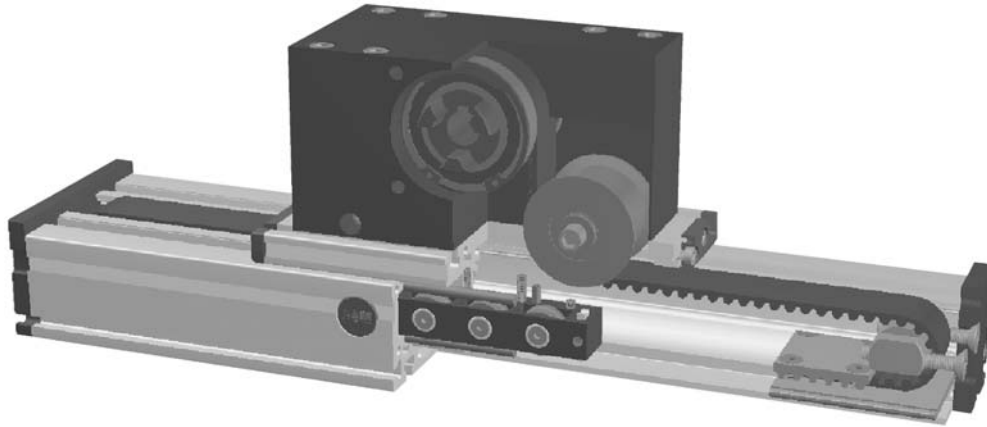

Function:

This linear unit consists of a rectangular aluminium profile with integrated, hardened steel guide rods. The carriage which has linear ball bearings that can be adjusted free of play is driven along the guide rods by a timing belt. Each standard pulley includes a coupling claw on one side and is equipped with maintenance-free ball bearings. Belt tension can be readjusted by a simple screw adjustment device in the carriage. This device can also be used for symmetrical adjustment of two or more linear units running parallel.

Fitting position:

As required. Max. length 6.000 mm without joints.

Carriage mounting:

By T-slots.

Unit mounting:

By T-slots and mounting sets. The linear axis can be combined with any T-slot profile.

Belt performance:

HTD with steel reinforcement, no backlash when changing direction, repeatability $\pm 0,1$ mm.

Carriage support:

In the standard version, the carriage runs on 8 rollers which can be adjusted and serviced at a central servicing position. For longer carriages the number of rollers can be increased.

7.1



Forces and torques

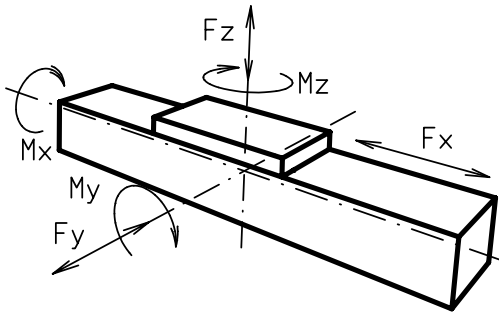

Size	120		160		200	
	static	dynamic	static	dynamic	static	dynamic
Forces/Torques						
F_x (N)	1900	1800	4000	3800	5900	5750
F_y (N)	1100	900	3000	2000	4400	3100
F_z (N)	1250	1000	3500	2800	4900	4400
M_x (Nm)	150	125	400	320	600	510
M_y (Nm)	140	120	360	300	560	480
M_z (Nm)	100	90	180	150	310	275
All forces and torques related to the following:						
existing values $\frac{F_y}{F_{y_{dyn}}} + \frac{F_z}{F_{z_{dyn}}} + \frac{M_x}{M_{x_{dyn}}} + \frac{M_y}{M_{y_{dyn}}} + \frac{M_z}{M_{z_{dyn}}} \leq 1$						
values of table						
No-load torque						
Nm	1,1		1,5		1,8	
Speed						
(m/sec) max	4		6		8	
Tensile force						
permanent (N)	1900		4000		5900	
0,2 sec (N)	2090		4300		6350	
Geometrical moments of inertia of aluminium profile						
I_x mm ⁴	$6,6 \times 10^5$		$2,22 \times 10^6$		$6,38 \times 10^6$	
I_y mm ⁴	$38,6 \times 10^5$		$12,20 \times 10^6$		$33,5 \times 10^6$	
Elastic modulus N/mm ²	70000		70000		70000	

For life-time calculation of rollers use our CD-ROM or homepage!

Formula: DLSZ

Driving torque:

$$M_o = \frac{F \cdot p \cdot S}{2000 \cdot \pi} + M_{leer}$$

$$P_o = \frac{M_o \cdot n}{9550}$$

- F = force (N)
- P = thread pitch (mm)
- S = safety factor 1,2 ... 2
- M_{leer} = no-load torque (Nm)
- n = rpm of screw (min⁻¹)
- M_o = driving torque (Nm)
- P_o = motor power (KW)

$$f = \frac{F \cdot L^3}{E \cdot I \cdot 192}$$

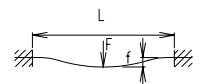

- f = deflection (mm)
- F = load (N)
- L = free length (mm)
- E = elastic modulus 70000 (N/mm²)
- I = second moment of area (mm⁴)

Positioning system DLSZ 120, 160, 200

Dimensions (mm)

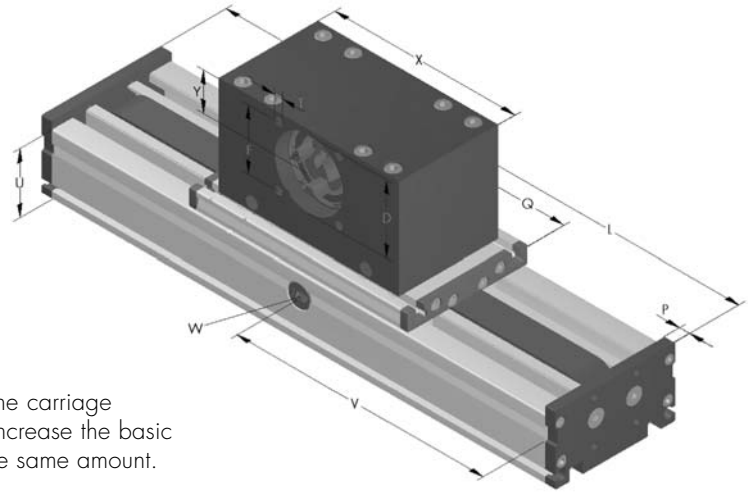
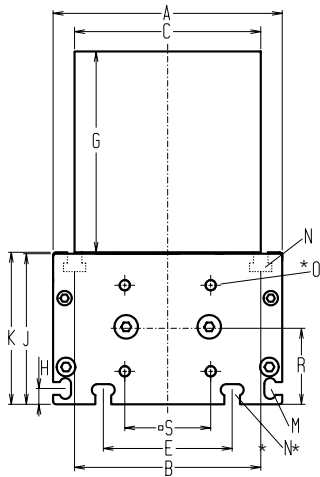

Increasing the carriage length will increase the basic length by the same amount.

*For slide-nuts refer to chapter 2.2 page 2

$V = Q + 100 \text{ mm}$

W = servicing position

Size □	Basic length L	A	B	C	D	E	F	G	H	J	K	M for	N for	O for	P	Q	R	S	T	U	X	Y	Basic weight	Weight per 100 mm
DLSZ 120	230	120	96	100	68	78	60	100	10	78	79	M 5	M 6	M 6	10	200	39	42	M 8	60	180	39	12,0 kg	1,2 kg
DLSZ 160	330	160	130	130	90	90	80	130	11	105	106	M 6	M 8	M 8	12	290	53	60	M 10	80	270	60	27,0 kg	1,8 kg
DLSZ 200	380	200	160	160	110	140	100	145	15	128	129	M 8	M 10	M 10	15	340	69	95	M 10	100	310	62	53,0 kg	2,6 kg

Choice of guide body profile:

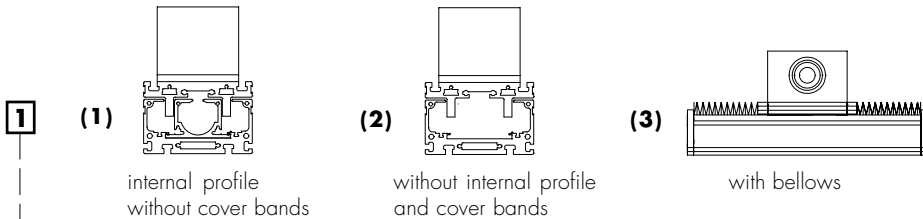

Stainless versions upon request.

Choice of carriages:

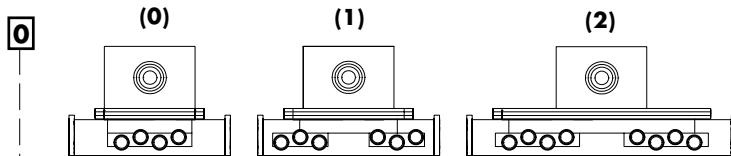

Size	Version 0		Version 1		Version 2	
	Q	L	Q	L	Q	L
120	200	230	>280	>310	>360	>390
160	290	330	>390	>430	>490	>530
200	340	380	>480	>520	>610	>650

Coupling - Selection of shaft mounting:

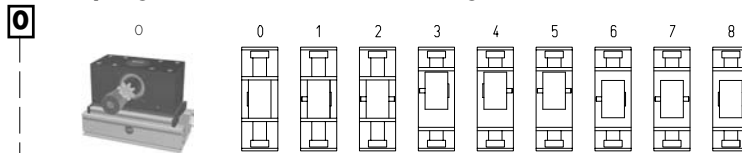

8 is as 0, but with coupling claws on both sides. The standard version is supplied without shaft. A shaft can be retrofitted by inserting in the pulley bore and securing with 2 locking rings or tension sets (size 200).

Belt table

Code No.	Size	Belt	mm/rev.	Number of teeth
0 7	120	8M30	192	24
0 9	160	8M50	256	32
1 0	200	8M70	304	38

Shaft dimensions

Size	Shaft \varnothing h6 x length	Key
120	18 x 45	6x6x40
160	22 x 45	6x6x40
200	30 x 55	8x7x44

Basic length + stroke = total length

DLSZ 120 1 1 0 0 0 7 2 01500
Pos. 1 2 3 4 5 6 7

Inductive proximity switch sets, which can be mounted inside of the square profile, are available as accessories. Coupling and a special plug are mounted from the outside. For additional accessories refer to chapter 2.2 – 4.2.

Sample ordering code:

DLSZ120, body profile with internal profile without cover bands, standard carriage, coupling claws on one side, 1270 mm stroke

