

# Positioning system DLZ 120, 160, 200

Specifications

## Belt drive

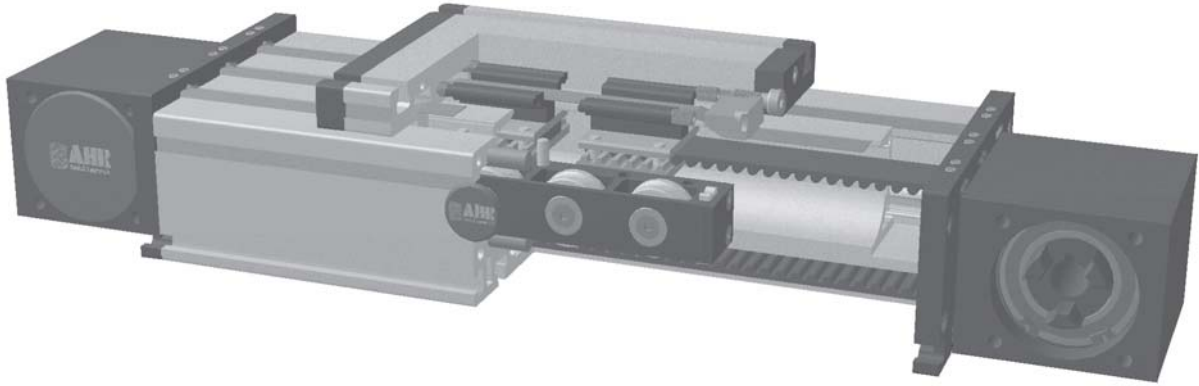

### Function:

This unit consists of a rectangular aluminium profile with 2 integrated roller guides. The carriage is moved by a belt drive. Each standard pulley has got one coupling claw on one side. Belt tension can be readjusted by a simple screw adjustment device in the carriage. This device can also be used for symmetrical adjustment of two or more linear units running parallel. The openings of the guide body are sealed with 3 stainless steel cover bands to protect the guide from splash water and dust. Alternatively, the opening can also be covered with a bellow or can be delivered without cover bands.

### Fitting position:

As required. Max. length 6.000 mm without joints.

### Carriage mounting:

By T-slots.

### Unit mounting:

By T-slots and mounting sets. The linear axis can be combined with any T-slot profile.

### Belt type:

HTD with steel reinforcement, no backlash when changing direction, repeatability ± 0,1 mm.

### Carriage support:

In the standard version, the carriage runs on 8 rollers which can be adjusted and serviced at a central servicing position. For longer carriages the number of rollers can be increased.

7.1



Forces and torques	Size	120		160		200	
	Forces/Torques	static	dynamic	static	dynamic	static	dynamic
$F_x$ (N)		894	800	1900	1800	4000	3800
$F_y$ (N)		1100	900	3000	2000	4400	3100
$F_z$ (N)		1250	1000	3500	2800	4900	4400
$M_x$ (Nm)		150	125	400	320	600	510
$M_y$ (Nm)		140	120	360	300	560	480
$M_z$ (Nm)		100	90	180	150	310	275
<b>All forces and torques related to the following:</b>							
existing values $\frac{F_y}{F_{y_{dyn}}} + \frac{F_z}{F_{z_{dyn}}} + \frac{M_x}{M_{x_{dyn}}} + \frac{M_y}{M_{y_{dyn}}} + \frac{M_z}{M_{z_{dyn}}} \leq 1$							
values of table							
<b>No-load torque</b>							
Nm		3,5		3,8		4,0	
<b>Speed</b>							
(m/sec) max		4		6		8	
<b>Tensile force</b>							
permanent (N)		900		1900		4000	
0,2 sec (N)		1000		2090		4300	
<b>Geometrical moments of inertia of aluminium profile</b>							
$I_x$ mm <sup>4</sup>		6,6x10 <sup>5</sup>		22,2x10 <sup>5</sup>		63,8x10 <sup>5</sup>	
$I_y$ mm <sup>4</sup>		38,6x10 <sup>5</sup>		122,0x10 <sup>5</sup>		335x10 <sup>5</sup>	
Elastic modulus N/mm <sup>2</sup>		70000		70000		70000	

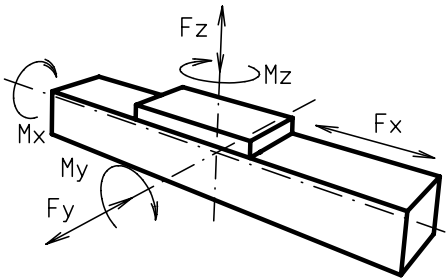

For life-time calculation of rollers use our CD-ROM or homepage!

### Formula: DLZ

Driving torque:

$$M_o = \frac{F \cdot P \cdot S}{2000 \cdot \pi} + M_{leer}$$

$$P_o = \frac{M_o \cdot n}{9550}$$

- F = force (N)
- P = pulley action perimeter (mm)
- S = safety factor 1,2 ... 2
- $M_{leer}$  = no-load torque (Nm)
- n = rpm pulley (min<sup>-1</sup>)
- $M_o$  = driving torque (Nm)
- $P_o$  = motor power (KW)

$$f = \frac{F \cdot L^3}{E \cdot I \cdot 192}$$

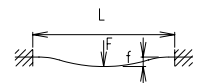

- f = deflection (mm)
- F = load (N)
- L = free length (mm)
- E = elastic modulus 70000 (N/mm<sup>2</sup>)
- I = second moment of area (mm<sup>4</sup>)

# Positioning system DLZ 120, 160, 200

Dimensions (mm)

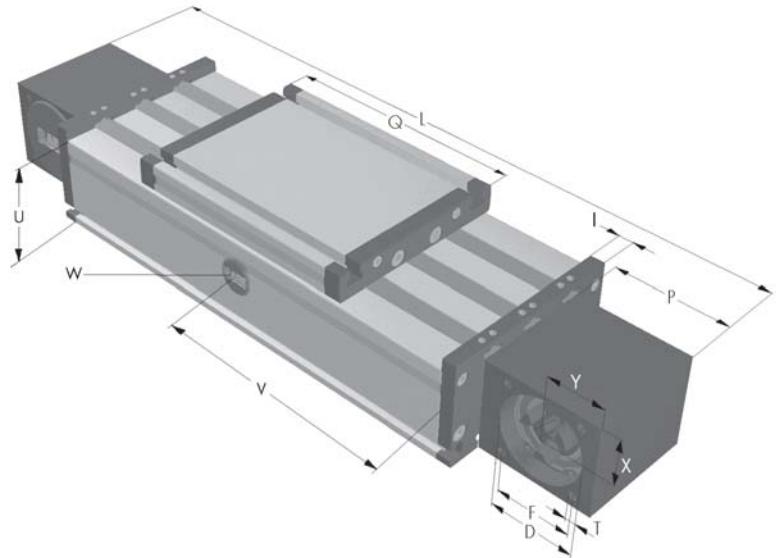
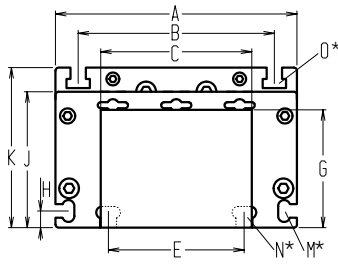

Increasing the carriage length will increase the basic length by the same amount.

\*For slide-nuts refer to chapter 2.2 page 2  $V = Q + 100 \text{ mm}$   $W = \text{servicing position}$

Size	Basic length L	A	B	C	D	E	F	G	H	I	J	K	M for	N for	O for	P	Q	T	U	X	Y	Basic weight	Weight per 100 mm
DLZ 120	330	120	96	80	47	78	42	60	10	10	68	79	M 5	M 6	M 6	70	156	M 6	60	30	35	5,1 Kg	0,85 Kg
DLZ 160	440	160	130	100	68	90	60	78	11	12	90	106	M 6	M 8	M 8	95	200	M 8	80	39	45	13,0 kg	1,69 kg
DLZ 200	530	200	160	130	90	140	80	97	15	15	110	129	M 8	M10	M10	110	270	M10	100	49	50	23,4 kg	2,33 kg

7.1

### Choice of guide body profile:

(0) internal profile with cover bands  
 (1) internal profile without cover bands  
 (2) without internal profile and cover bands  
 (3) with bellows

Stainless versions upon request.

### Choice of carriage:

(0) (2)   
 (3)

Size	Version 0		Version 2		Version 3	
	Q	L	Q	L	Q	L
120	156	330	196	370	>236	>410
160	200	440	250	490	>300	>540
200	270	540	330	600	>410	>680

### Coupling - Selection of shaft mounting:

0 0 1 2 3 4 5 6 7 8 9

9 is as 0, but with coupling claws on both sides.

The standard version is supplied without shaft. A shaft can be retrofitted by inserting in the pulley bore and securing with 2 locking rings or tension sets (size 200).

### Belt table

Code No.	Size	Belt	mm/rev.	Number of teeth
0 4	120	5M25	130	26
0 7	160	8M30	176	22
0 9	160	8M50	176	22
0 9	200	8M50	224	28

### Shaft dimensions

Size	Shaft $\phi$ h6 x length	Key
120	14 x 35	5x5x28
160	18 x 45	6x6x40
160(8M50)	25 x 35	8x8x32
200	22 x 45	6x6x40

Basic length + stroke = total length

DLZ 160 1 0 0 0 0 7 1 01500  
Pos. 1 2 3 4 5 6 7

Inductive proximity switch sets, which can be mounted inside of the square profile, are available as accessories. Coupling and a special plug are mounted from the outside. For additional accessories refer to chapter 2.2 - 4.2.

Sample ordering code:

DLZ160 with internal profile and cover bands, standard carriage, coupling claw on one side, 1060 mm stroke.

