

Positioning system ELT/ELK 30, 40, 60, 80, 80S, 100, 125 Specifications

1.1 Spindle driven with trapezoidal- or ballscrew spindle

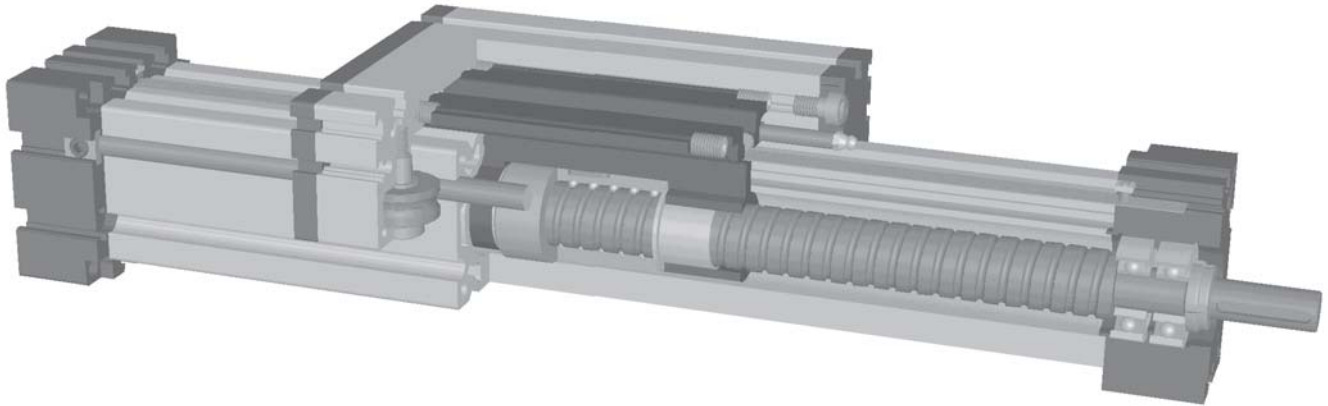

Function:

This linear unit consists of an aluminium hollow section with integral, parallel ground and hardened steel guide rods. The carriage has play-adjustable ball-bearing rollers which engage with the guide rods. The rotating ballscrew causes linear motion of the ballnut, which is connected to the carriage. The slot necessary for this is covered by a stainless steel strip, making the unit dust- and splash-proof. Lateral adjustment of movement for parallel units, or when two carriages are mounted on one unit, is provided by the ballnut mounting.

- Fitting position:** As required, max. length 3.000 mm
- Carriage mounting:** By T-slots and tapped holes
- Unit mounting:** By T-slots and tapped holes in the mounting surfaces.

Forces and torques	Size	EL 30		EL 40		EL 60		EL 80		EL 80S		EL 100		EL 125	
	Forces/Torques	static	dyna.	static	dyna.	static	dyna.	static	dyna.	static	dyna.	static	dyna.	static	dyna.
F_x (N)		750	600	1500	1200	2500	2000	5000	4000	5000	4000	10000	8000	15000	12000
F_y (N)		90	60	1200	700	3000	2000	3000	2000	4600	3600	8000	6500	12000	9000
F_z (N)		90	60	900	650	1700	1100	1700	1100	3000	1800	3600	2200	6000	4500
M_x (Nm)		12	10	25	20	67	43	90	55	170	140	300	230	600	450
M_y (Nm)		12	10	32	18	90	70	110	80	270	230	400	270	750	600
M_z (Nm)		15	12	35	25	120	100	150	120	300	220	750	500	1350	1150

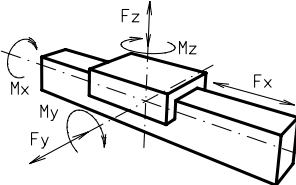

All forces and torques relate to the following:
 existing values $\frac{F_y}{F_{y_{dyn}}} + \frac{F_z}{F_{z_{dyn}}} + \frac{M_x}{M_{x_{dyn}}} + \frac{M_y}{M_{y_{dyn}}} + \frac{M_z}{M_{z_{dyn}}} \leq 1$
 values of table

No-load torque							
Trapezoidal thread	10x3	18x4/18x8	24x5/24x10	28x5/28x10	28x5/28x10	32x6/32x12	40x7/40x14
(Nm)	0,3	0,4/0,5	0,6/0,8	0,8/1,0	0,8/1,0	0,9/1,1	1,2/1,4
Ballscrew	8x2,5	16x5/16x10	25x5/25x10	32x5/32x10	32x5/32x10	32x5/32x10	40x10/40x20
(Nm)	0,15	0,2/0,4	0,4/0,6	0,6/0,8	0,6/0,8	0,7/0,9	1,0/1,2

Geometrical moments of inertia of aluminium profile							
I_x mm ⁴	4,09x10 ⁴	1,32x10 ⁵	6,79x10 ⁵	18,99x10 ⁵	18,99x10 ⁵	44,4x10 ⁵	101,5x10 ⁵
I_y mm ⁴	4,00x10 ⁴	1,34x10 ⁵	6,97x10 ⁵	18,97x10 ⁵	18,97x10 ⁵	44,8x10 ⁵	101,5x10 ⁵
E-Modulus N/mm ²	70000	70000	70000	70000	70000	70000	70000

For life-time calculation of rollers use our CD-ROM or homepage!

Formula: ELT/K

Driving torque:

$$M_o = \frac{F \cdot p \cdot S}{2000 \cdot \pi \cdot \mu} + M_{leer}$$

$$P_o = \frac{M_o \cdot n}{9550}$$

- F = force (N)
- p = thread pitch (mm)
- S_i = safety factor 1,2 ... 2
- M_{leer} = no-load torque (Nm)
- n = rpm of screw (min⁻¹)
- M_o = driving torque (Nm)
- μ = screw efficiency
- P_o = motor power (KW)

Efficiency of lead screws:

All ballscrew	0.900
Tr 10x3	0.375
Tr 18x4	0.399
Tr 18x8	0.565
Tr 24x5	0.384
Tr 24x10	0.550
Tr 28x5	0.349
Tr 28x10	0.513
Tr 32x6	0.360
Tr 32x12	0.524
Tr 40x7	0.344
Tr 40x14	0.509

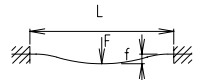
$$f = \frac{F \cdot L^3}{E \cdot I \cdot 192}$$

- f = deflection (mm)
- F = load (N)
- L = free length (mm)
- E = elastic modulus 70000 (N/mm²)
- I = second moment of area (mm⁴)

The diagram for critical speeds of lead screws refer to chapter 5.2 page 3



Positioning system ELT/ELK 30, 40, 60, 80, 80S, 100, 125

Dimensions (mm)

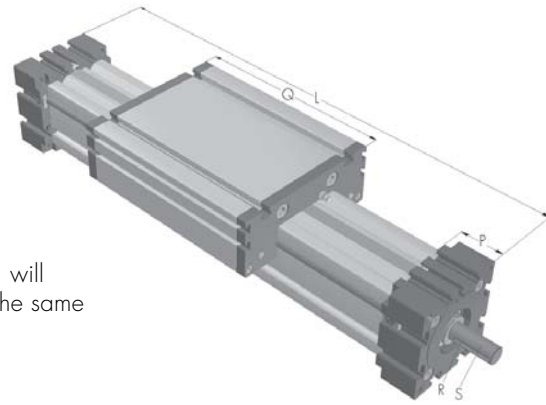
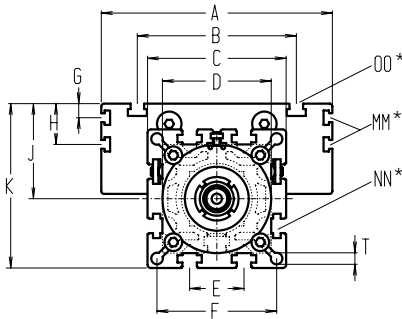

Increasing the carriage length will increase the basic length by the same amount.

*For slide-nuts refer to chapter 2.2 page 2

Size	Basic length L	A	B	C	D	E	F	G	H	J	K	MM for	NN for	OO for	P	Q	R	S ∅ x length	T	Basic weight	Weight per 100 mm
EL 30	120	70	56	42	40x1	13	35	-	-	26	47	-	M 6	M 6	18	82	-	5x15	4,2	0,7 kg	0,16 kg
EL 40	175	100	66	58	48x1	18	47	-	-	35	64	-	M 6	M 6	25	122	3x3x25	10x27	6,5	1,7 kg	0,37 kg
EL 60	245	144	96	82	62x1	30	69	-	-	49	90	-	M 8	M 8	35	168	5x5x28	14x35	8,5	5,1 kg	0,89 kg
EL 80	285	170	117	102	80x1	40	88	10	30	70	121	M 6	M 10	M 10	45	194	6x6x40	18x45	8,5	10,0 kg	1,48 kg
EL 80S	305	190	126	102	80x1	40	88	12,5	30	71	122	M 6	M 10	M 8	45	214	6x6x40	18x45	8,5	11,0 kg	1,48 kg
EL 100	410	230	155	130	110x1	50	112	-	29	89	154	M 10	M 10	M 10	55	300	6x6x40	22x45	10,5	19,0 kg	2,00 kg
EL 125	510	295	200	165	130x1	60	142	-	30	107,5	190	M 10	M 12	M 12	65	365	8x7x50	25x55	13,0	33,0 kg	2,89 kg

Spindle:

T (T) Trapezoidal thread (K) Ballscrew

Selection of screw:

1 (1) right hand (2) left hand (Ballscrew by inquiry)

Choice of guide body profile:

0 (0) Standard (1) stainless guide rod (2) stainless guide rods and screws (3) stainless guide rods, rollers and screws

Choice of carriages:

0 (0)



For standard carriage length see 'Q' in table. Non-standard length on request. The longer the carriage, the greater the load capacity.

(1)



Top and bottom carriages are rigidly joined, enabling higher loads to be applied. This increases the basic length by 12-24 mm. Thickness of jointing plate refer to chapter 1.2 page 6.

Choice of journal:

0 (0) one shaft (locating bearing side) (1) one shaft (non-locating bearing side) (2) shaft on both sides

Selection of screw:

0

Size	Standard trapezoidal thread	Multistart-screw trapezoidal thread	Standard ballscrew	Multistart-screw ballscrew
30	(0) Tr 10x3		(0) Kg 8x2,5	
40	(0) Tr 18x4	(1) Tr 18x8	(0) Kg 16x5	(1) Kg 16x10 (2) Kg 16x16
60	(0) Tr 24x5	(1) Tr 24x10	(0) Kg 25x5	(1) Kg 20x20 (2) Kg 25x10 (3) Kg 20x50
80	(0) Tr 28x5	(1) Tr 28x10	(0) Kg 32x5	(1) Kg 25x25 (2) Kg 32x10
100	(0) Tr 32x6	(1) Tr 32x12	(0) Kg 32x5	(1) Kg 32x10 (2) Kg 32x20 (3) Kg 32x32
125	(0) Tr 40x7	(1) Tr 40x14	(0) Kg 40x10	(1) Kg 40x20 (2) Kg 40x40

Ballscrew pitch accuracy:

0 (0) 0,1 mm / 300 mm (Standard) (1) 0,05 mm / 300 mm (2) 0,025 mm / 300 mm

End play of ball nut:

0 (0) 0,04 mm (Standard), (1)* < 0,02 mm, (2)* 2% apply prestress
* only in combination with pitch accuracy (1) or (2)

Repeatability:

± 0,2 mm Trapezoidal
± 0,025 mm Ballscrew

1500 Basic length + stroke = total length

EL T 40 1 0 0 0 0 0 0 0 1500

Pos. 1 2 3 4 5 6 7

Sample ordering code:

ELT40, trapezoidal right hand thread, standard body profile, top carriage, one shaft (locating bearing side), spindle 18x4, 1325 mm stroke

For combination kits and connecting elements refer to chapter 2.2



Positioning system ELT/ELK 30, 40, 60, 80, 80S, 100, 125 Dimensions (mm)

with trapezoidal thread or ballscrew, right-hand and left-hand thread or divided spindles

1.1

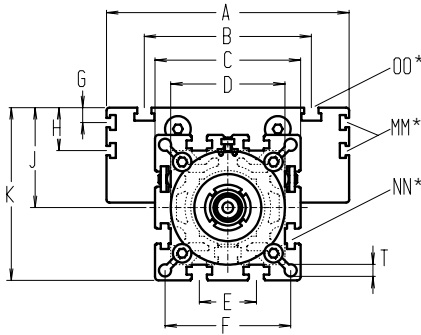

Increasing the carriage length will increase the basic length by the same amount.

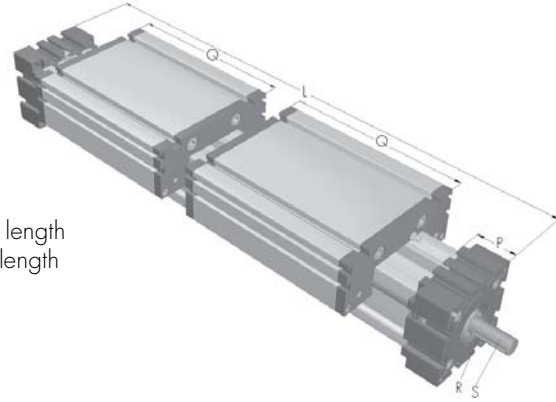

*For slide-nuts refer to chapter 2.2 page 2

Size □	Basic length L	A	B	C	D	E	F	G	H	J	K	MM for	NN for	OO for	P	Q	R	S Ø x length	T	Basic weight	Weight per 100 mm
EL 30	202	70	56	42	40x1	13	35	-	-	26	47	-	M 6	M 6	18	82	-	5 x 15	4,2	1,1 kg	0,16 kg
EL 40	300	100	66	58	48x1	18	47	-	-	35	64	-	M 6	M 6	25	122	3x3x25	10 x 27	6,5	2,5 kg	0,37 kg
EL 60	410	144	96	82	62x1	30	69	-	-	49	90	-	M 8	M 8	35	168	5x5x28	14 x 35	8,5	8,1 kg	0,89 kg
EL 80	480	170	117	102	80x1	40	88	10	30	70	121	M 6	M10	M10	45	194	6x6x40	18 x 45	8,5	15,0 kg	1,48 kg
EL 80S	520	190	126	102	80x1	40	88	12,5	30	71	122	M 6	M10	M 8	45	214	6x6x40	18 x 45	8,5	17,0 kg	1,48 kg
EL 100	720	230	155	130	110x1	50	112	-	29	89	154	M10	M10	M10	55	300	6x6x40	22 x 45	10,5	32,0 kg	2,00 kg
EL 125	880	295	200	165	130x1	60	142	-	30	107,5	190	M10	M12	M12	65	365	8x7x50	25 x 55	13	48,0 kg	2,89 kg

Spindle:

T (T) Trapezoidal thread (K) Ballscrew

Selection of screw:

3 (3) right - left hand (4) divided spindle

Choice of guide body profile:

0 (0) Standard (1) stainless guide rod (2) stainless guide rods and screws (3) stainless guide rods, rollers and screws

Choice of carriages:



For standard carriage length see 'Q' in table. Non-standard length on request. The longer the carriage, the greater the load capacity.



Top and bottom carriages are rigidly joined, enabling higher loads to be applied. This increases the basic length by 24-48 mm. Thickness of jointing plate refer to chapter 1.2 page 6.

Choice of journal:

0 (0) shaft right hand thread (1) shaft left hand thread (2) shaft on both sides

Selection of screw:

Size	Standard trapezoidal thread	Multistart-screw trapezoidal thread	Standard ballscrew	Multistart-screw ballscrew
30	(0) Tr 10x3		(0) Kg 8x2.5*	
40	(0) Tr 18x4	(1) Tr 18x8	(0) Kg 16x5	(1) Kg 16x10* (1) Kg 16x16*
60	(0) Tr 24x5	(1) Tr 24x10	(0) Kg 25x5	(1) Kg 20x20* (2) Kg 25x10*
80	(0) Tr 28x5	(1) Tr 28x10	(0) Kg 32x5	(1) Kg 25x25* (2) Kg 32x10*
100	(0) Tr 32x6	(1) Tr 32x12	(0) Kg 32x5	(1) Kg 32x10* (2) Kg 32x20* (3) Kg 32x32*
125	(0) Tr 40x7	(1) Tr 40x14	(0) Kg 40x10	(1) Kg 40x20* (2) Kg 40x40*

* = only for selection of divided spindle

Ballscrew pitch accuracy:

0 (0) 0,1 mm / 300 mm (Standard) (1) 0,05 mm / 300 mm (2) 0,025 mm / 300 mm

End play of ball nut:

0 (0) 0,04 mm (Standard), **(1)*** < 0,02 mm, **(2)*** 2% apply prestress
* only in combination with **pitch accuracy (1) or (2)**

Repeatability:

± 0,2 mm Trapezoidal
± 0,025 mm Ballscrew

2200 Basic length + stroke = total length

EL T 40 3 0 0 0 0 0 0 0 2200

Pos. 1 2 3 4 5 6 7

For combination kits and connecting elements refer to chapter 2.2

Sample ordering code:

ELT40, trapezoidal right - left hand thread, standard body profile, 2 top carriage, shaft on right hand side, spindle 18x4, 1900 mm stroke

