

Positioning system ELVZ 60, 80, 80S, 100, 125

Specifications

Internal belt drive

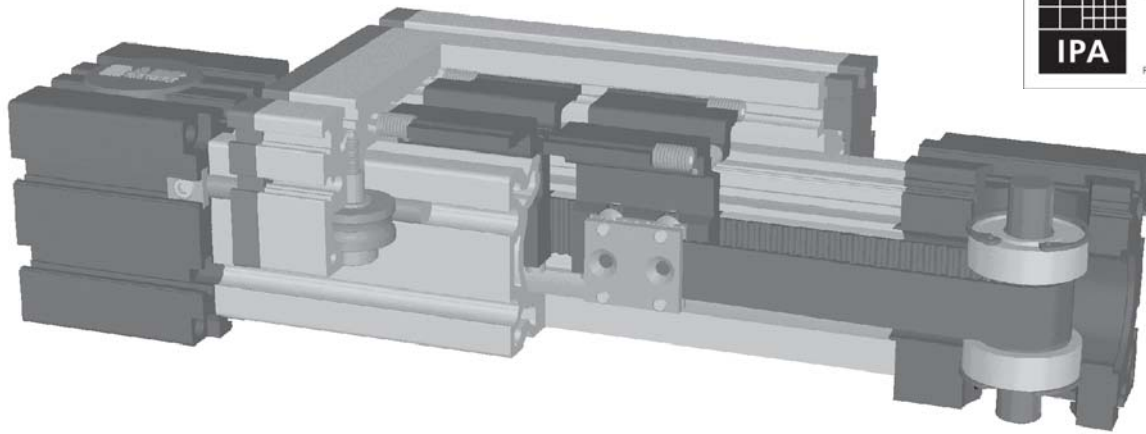

3.1

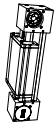

Function:

This linear unit consists of an aluminium square profile with integrated, hardened steel guide rods. The carriage which has internal linear ball bearings that can be adjusted free of play is driven along the guide rods by a toothed belt. Toothed pulley has maintenance-free ball bearings. Belt tension can be readjusted by a simple screw adjustment device in the carriage. This device can also be used for symmetrical adjustment of two or more linear units running parallel.

This linear unit is suitable for application in clean rooms of clean-room classification 1.000 (corresponding to US Fed. Standard 209 E).

Fitting position: As required. Max. length 3.000 mm without joints.

Carriage mounting: By T-slots.

Unit mounting: By tapped holes or tapped holes in the bearing block, mounting sets.

Belt type: HTD with steel reinforcement, no backlash when changing direction, repeatability ± 0,1 mm.

Forces and torques	Size	ELVZ 60		ELVZ 80		ELVZ 80 S		ELVZ 100		ELVZ 125	
	Forces/Torques	static	dynamic	static	dynamic	static	dynamic	static	dynamic	static	dynamic
F_x (N)		700	580	1000	840	1000	840	3100	2600	5000	4950
F_y (N)		3000	2000	3000	2000	4600	3600	8000	6500	12000	9000
F_z (N)		1700	1100	1700	1100	3000	1800	3600	2200	6000	4500
M_x (Nm)		67	43	90	55	170	140	300	230	600	450
M_y (Nm)		90	70	110	80	270	230	400	270	750	600
M_z (Nm)		120	100	150	120	300	220	750	500	1350	1150

All forces and torques relate to the following:						
existing values	F_y	F_z	M_x	M_y	M_z	
values of table	$F_{y_{dyn}}$	$F_{z_{dyn}}$	$M_{x_{dyn}}$	$M_{y_{dyn}}$	$M_{z_{dyn}}$	≤ 1

No-load torque						
Nm		0,5	0,8	1,2	1,2	1,6

Speed						
(m/sec) max		3	4	4	5	6

Tensile force						
permanent (N)		700	1000	1000	3100	5000
0,2 sec (N)		800	1150	1150	3400	5450

Geometrical moments of inertia of aluminium profile						
I_x mm ⁴		6,79x10 ⁵	18,99x10 ⁵	18,99x10 ⁵	44,4x10 ⁵	101,5x10 ⁵
I_y mm ⁴		6,97x10 ⁵	18,97x10 ⁵	18,97x10 ⁵	44,8x10 ⁵	101,5x10 ⁵
E-Modulus N/mm ²		70000	70000	70000	70000	70000

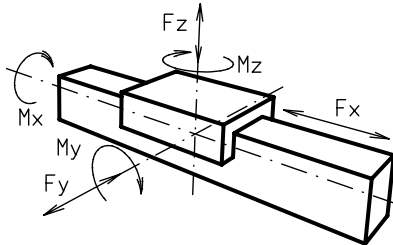

For life-time calculation of rollers use our CD-ROM or homepage!

Formula: ELVZ

Driving torque:

$$M_o = \frac{F \cdot P \cdot S}{2000 \cdot \pi} + M_{leer}$$

$$P_o = \frac{M_o \cdot n}{9550}$$

- F = force (N)
- P = pulley action perimeter (mm)
- S = safety factor 1,2 ... 2
- M_{leer} = no-load torque (Nm)
- n = rpm pulley (min⁻¹)
- M_o = driving torque (Nm)
- P_o = motor power (KW)

$$f = \frac{F \cdot L^3}{E \cdot I \cdot 192}$$

- f = deflection (mm)
- F = load (N)
- L = free length
- E = elastic modulus 70000 (N/mm²)
- I = second moment of area (mm⁴)



Positioning system ELVZ 60, 80, 80S, 100, 125

Dimensions (mm)

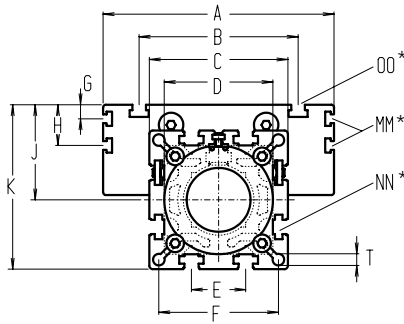

Increasing the carriage length will increase the basic length by the same amount

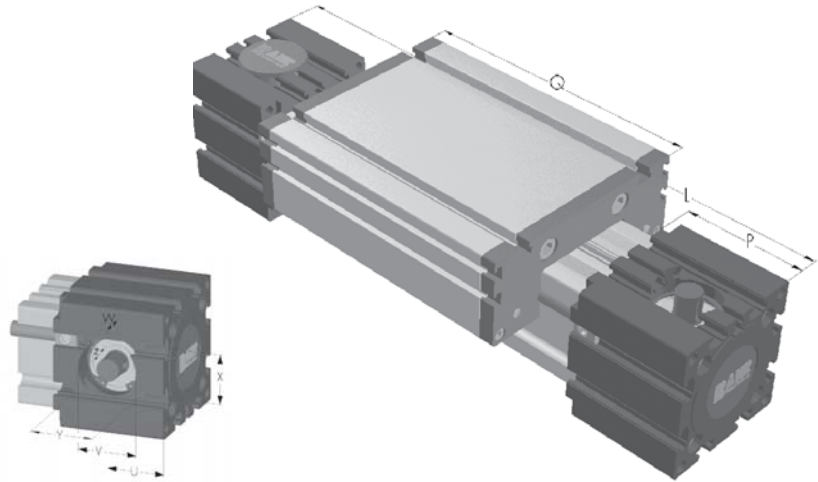

*For slide-nuts refer to chapter 2.2 page 2

Size □	Basic length L	A	B	C	D	E	F	G	H	J	K	MM for	NN for	OO for	P	Q	T	U	V	W	X	Y	Z	Basic weight	Weight per 100 mm
ELVZ 60	290	144	96	82	62x1	30	69	-	-	49	90	-	M 8	M 8	59	168	8,5	23	37	14	30	36	M 6	4,8 kg	0,62 kg
ELVZ 80	375	170	117	102	80x1	40	88	10	30	70	121	M 6	M10	M10	90	194	8,5	38	47	18	40	50	M 8	10,0 kg	1,00 kg
ELVZ 80S	395	190	126	102	80x1	40	88	12,5	30	71	122	M 6	M10	M 8	90	214	8,5	38	47	18	40	50	M 8	11,0 kg	1,00 kg
ELVZ 100	530	230	155	130	110x1	50	112	-	29	89	154	M10	M10	M10	110	300	10,5	45	68	19	50	64	M10	24,0 kg	1,60 kg
ELVZ 125	625	295	200	165	130x2	60	142	-	30	107,5	190	M10	M10	M12	132	365	13	58	90	35	60	85	M10	37,0 kg	2,10 kg

1 (1) Belt connection right

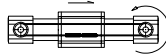

(2) Belt connection left



Choice of guide body profile:

0 (0) Standard **(1)** stainless guide rods **(2)** stainless guide rods and screws **(3)** stainless guide rods, rollers and screws

Choice of carriages:

0 (0)



(1)



For standard carriage length see 'Q' in table. The carriages can be delivered in any non-standard length upon request; the longer the carriage, the greater the load capacity.

Top and bottom carriages are rigidly joined, thus enabling higher loads to be applied. This increases the basic length by 16 - 24 mm. For thickness of jointing plate refer to chapter 1.2 page 6.

Selection of shaft mounting:

0

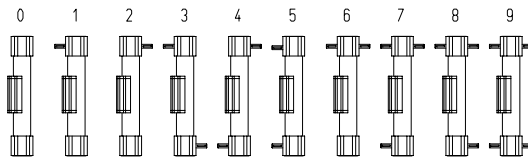

The standard version 0 is supplied with 4 flush mounted shafts.

Belt table

Code No.	Size	Belt	mm/rev.	Number of teeth
0 4	60	5M25	80	16
0 4	80 (S)	5M25	110	22
0 9	100	8M50	144	18
0 9	125	8M50	192	24

Shaft dimensions

Size	Shaft ø h6 x length	Key
60	14 x 35	5x5x28
80 (S)	18 x 45	6x6x40
100	22 x 45	6x6x40
125	30 x 55	8x7x40

Basic length + stroke = total length

ELVZ 60 1 0 0 0 0 4 1 01500
Pos. 1 2 3 4 5 6 7

For combination kits and connecting elements refer to chapter 2.2

Sample ordering code:

ELVZ 60 with belt connection right, standard body profile, standard carriage and 4 flush mounted shafts, 1210 mm stroke



Positioning system ELVZ 60, 80, 80S, 100, 125

Dimensions (mm)

Internal belt drive with two carriages moving in opposite directions

3.1

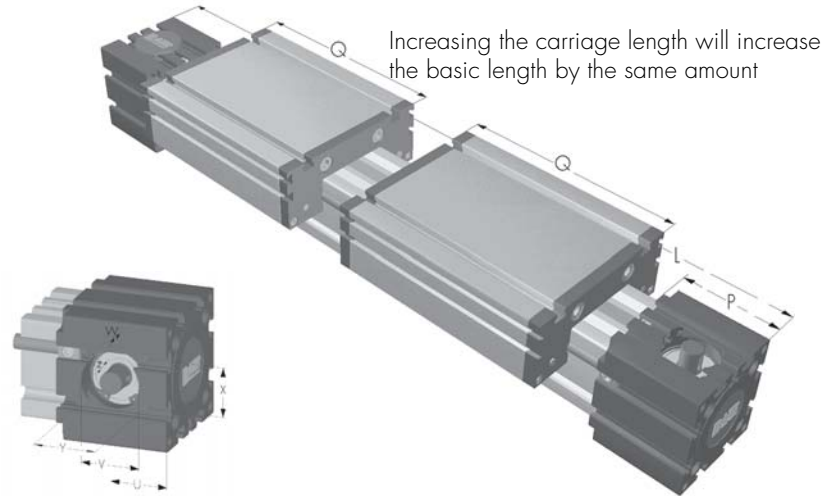
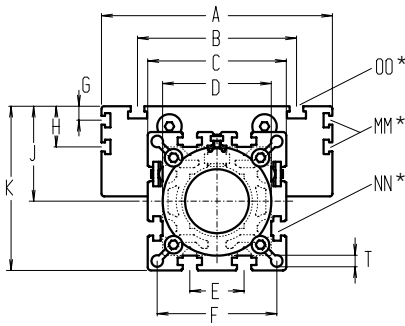
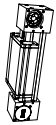

*For slide-nuts refer to chapter 2.2 page 2

Size	Basic length L	A	B	C	D	E	F	G	H	J	K	MM for	NN for	OO for	P	Q	T	U	V	W	X	Y	Z	Basic weight	Weight per 100 mm
ELVZ 60	460	144	96	82	62x1	30	69	-	-	49	90	-	M 8	M 8	59	168	8,5	24	37	14	30	36	M 6	6,5 kg	0,62 kg
ELVZ 80	570	170	117	102	80x1	40	88	10	30	70	121	M 6	M10	M10	90	194	8,5	38	47	18	40	50	M 8	13,0 kg	1,00 kg
ELVZ 80S	610	190	123	102	80x1	40	88	12,5	30	71	122	M 6	M10	M 8	90	214	8,5	38	47	18	40	50	M 8	15,0 kg	1,00 kg
ELVZ 100	830	230	155	130	110x1	50	112	-	29	89	154	M10	M10	M10	110	300	10,5	45	68	19	50	64	M10	31,0 kg	1,60 kg
ELVZ 125	990	295	200	165	130x2	60	142	-	30	107,5	190	M10	M10	M12	132	365	13	58	90	35	60	64	M10	50,5 kg	2,10 kg

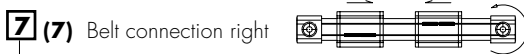

Choice of guide body profile:

(0) Standard (1) stainless guide rods (2) stainless guide rods and screws (3) stainless guide rods, rollers and screws

Choice of carriages:



For standard carriage length see 'Q' in table. The carriages can be delivered in any non-standard length upon request; the longer the carriage, the greater the load capacity.

Top and bottom carriages are rigidly joined, thus enabling higher loads to be applied. This increases the basic length by 32 - 48 mm. For thickness of jointing plate refer to chapter 1.2 page 6.

Selection of shaft mounting:

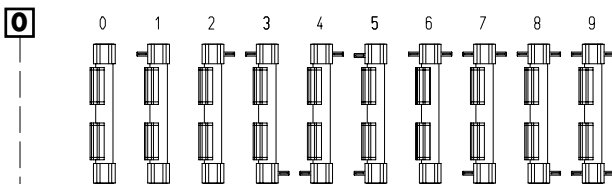

The standard version 0 is supplied with 4 flush mounted shafts.

Belt table

Code No.	Size	Belt	mm/rev.	Number of teeth
0 4	60	5M25	80	16
0 4	80 (S)	5M25	110	22
0 9	100	8M50	144	18
0 9	125	8M50	192	24

Shaft dimensions

Size	Shaft ø h6 x length	Key
60	14 x 35	5x5x28
80 (S)	18 x 45	6x6x40
100	22 x 45	6x6x40
125	30 x 55	8x7x40

Basic length + stroke = total length

ELVZ 60 7 0 0 0 0 4 1 01500
Pos. 1 2 3 4 5 6 7

For combination kits and connecting elements refer to chapter 2.2

Sample ordering code:

ELVZ 60 right-/left-hand with belt connection right, standard body profile, standard carriage and 4 flush mounted shafts, 1040 mm stroke

