

Positioning system ELZ 30, 40, 60, 60S, 80, 80S, 100, 125

Belt drive

Specifications

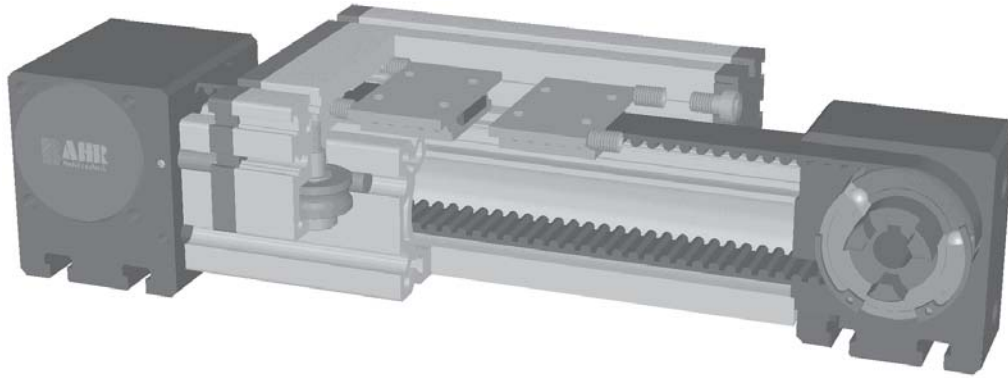

3.1



Function:

This linear unit consists of an aluminium square profile with integrated, hardened steel guide rods. The carriage which has internal linear ball bearings, that can be adjusted free of play is driven along the guide rods by a timing belt. The pulleys have maintenance-free ball bearings. Belt tension can be readjusted by a simple screw adjustment device in the carriage. This device can also be used for symmetrical adjustment of two or more linear units running parallel.

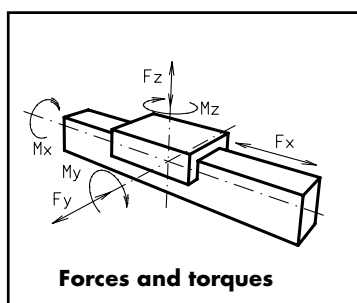

Fitting position: As required. Max. length 6.000 mm without joints.

Carriage mounting: By T-slots.

Unit mounting: By T-slots or tapped holes in the bearing block, mounting sets.

Belt type: HTD with steel reinforcement, no backlash when changing direction, repeatability: ± 0,1 mm.

Size	ELZ 30		ELZ 40		ELZ 60		ELZ 60 S		ELZ 80		ELZ 80 S		ELZ 100		ELZ 125	
	static	dynamic	static	dynamic	static	dynamic	static	dynamic	static	dynamic	static	dynamic	static	dynamic	static	dynamic
F_x (N)	200	180	390	350	894	800	894	800	1900	1800	1900	1800	4000	3800	5900	5750
F_y (N)	90	60	1200	700	3000	2000	4100	3100	3000	2000	4600	3600	8000	6500	12000	9000
F_z (N)	90	60	900	650	1700	1100	2160	1600	1700	1100	3000	1800	3600	2200	6000	4500
M_x (Nm)	10	5	25	20	67	43	88	65	90	55	170	140	300	230	600	450
M_y (Nm)	13	6	32	18	90	70	190	140	110	80	270	230	400	270	750	600
M_z (Nm)	14	7	35	25	120	100	230	170	150	120	300	220	750	500	1350	1150

All forces and torques relate to the following:
 existing values $\frac{F_y}{F_{y_{dyn}}} + \frac{F_z}{F_{z_{dyn}}} + \frac{M_x}{M_{x_{dyn}}} + \frac{M_y}{M_{y_{dyn}}} + \frac{M_z}{M_{z_{dyn}}} \leq 1$
 values of table

No-load torque								
Nm	0,2	0,3	0,6	0,7	0,9	1,2	1,4	1,8
Speed								
(m/sec) max	2	4	5	7	6	8	10	10
Tensile force								
permanent (N)	200	390	900	900	1900	1900	4000	5900
0,2 sec (N)	280	480	1000	1000	2090	2090	4300	6350
Geometrical moments of inertia of aluminium profile								
I_x mm ⁴	4,09x10 ⁴	1,32x10 ⁵	6,79x10 ⁵	6,79x10 ⁵	18,99x10 ⁵	18,99x10 ⁵	44,4x10 ⁵	101,5x10 ⁵
I_y mm ⁴	4,00x10 ⁴	1,34x10 ⁵	6,97x10 ⁵	6,97x10 ⁵	18,97x10 ⁵	18,97x10 ⁵	44,8x10 ⁵	101,5x10 ⁵
E-Modulus N/mm ²	70000	70000	70000	70000	70000	70000	70000	70000

For life-time calculation of rollers use our CD-ROM or homepage!

Formula: ELZ

Driving torque:

$$M_o = \frac{F * P * S}{2000 * \pi} + M_{leer}$$

$$P_o = \frac{M_o * n}{9550}$$

- F = force (N)
- P = pulley action perimeter (mm)
- S = safety factor 1,2 ... 2
- M_{leer} = no-load torque (Nm)
- n = rpm pulley (min⁻¹)
- M_o = driving torque (Nm)
- P_o = motor power (KW)

$$f = \frac{F * L^3}{E * I * 192}$$

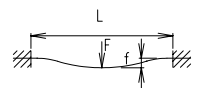

- f = deflection (mm)
- F = load (N)
- L = free length (mm)
- E = elastic modulus 70000 (N/mm²)
- I = second moment of area (mm⁴)



Positioning system ELZ 30, 40, 60, 60S, 80, 80S, 100, 125

Dimensions (mm)

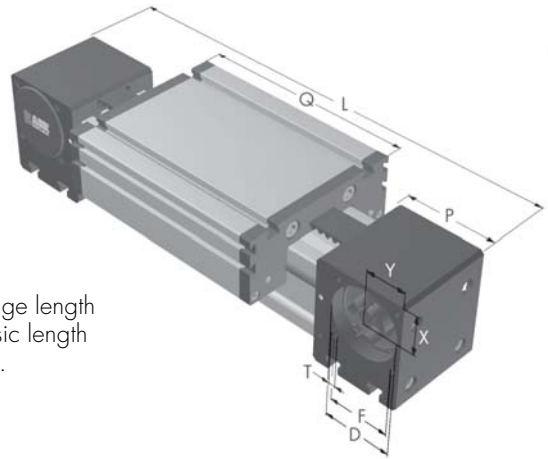
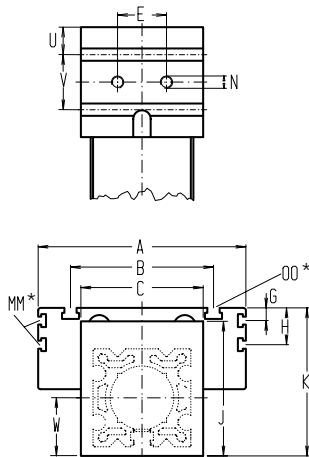

Increasing the carriage length will increase the basic length by the same amount.



*For slide-nuts refer to chapter 2.2 page 2

Size	Basic length L	A	B	C	D	E	F	G	H	J	K	MM for	N	OO for	P	Q	T	U	V	W	X	Y	Basic weight	Weight per 100 mm
ELZ 30	158	70	56	42	28	13	25	-	-	44	47	M 5	M 6	M 6	36	82	M 4	-	-	21	16	16	0,8 kg	0,13 kg
ELZ 40	225	100	66	58	37	18	32	-	-	58	64	M 6	M 6	M 6	49	122	M 5	12,5	24	29	20,5	20,5	1,9 kg	0,24 kg
ELZ 60	290	144	96	80	47	30	42	-	-	82	90	M 8	M 8	M 8	59	168	M 6	15	30	41	27	26	4,8 kg	0,62 kg
ELZ 60 S	314	170	108	80	47	30	42	-	-	82	90	M 8	M 8	M 8	59	194	M 6	15	30	41	27	26	5,8 kg	0,62 kg
ELZ 80	375	170	117	100	68	40	60	10	30	110	121	M 6	M 10	M 10	90	194	M 8	22,5	45	51	39	38	10,0 kg	1,00 kg
ELZ 80 S	395	190	126	100	68	40	60	12,5	30	110	122	M 6	M 10	M 8	90	214	M 8	22,5	45	51	39	38	11,0 kg	1,00 kg
ELZ 100	530	230	155	130	90	50	80	-	29	135	154	M 10	M 12	M 10	110	300	M 10	23	64	65	50	50	24,0 kg	1,60 kg
ELZ 125	625	295	200	160	110	60	100	-	30	167	191	M 10	M 12	M 12	130	365	M 10	38	50	82	60	60	37,0 kg	2,10 kg

Choice of guide body profile:
0 (0) Standard **(1)** stainless guide rods **(2)** stainless guide rods and screws **(3)** stainless guide rods, rollers and screws

Choice of carriages:

0 (0)



For standard carriage length see 'Q' in table. Non-standard length on request. The longer the carriage, the greater the load capacity.

(1)



Top and bottom carriages are rigidly joined, enabling higher loads to be applied. This increases the basic length by 12 - 24 mm. Thickness of jointing plate refer to chapter 1.2 page 6.

Coupling - shaft mounting:

0

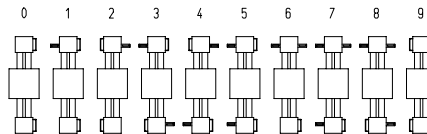

Version 9 is the same as 0, but with double sided coupling claw.

The standard version is supplied without shaft. A shaft can be retrofitted by inserting in the pulley bore and securing with 2 locking rings or tension sets (size 100 and 125).

Belt table

Code No.	Size	Belt	mm/rev.	Number of teeth
0 1	30	3M12	75	25
0 3	40	5M15	100	20
0 4	60 [S]	5M25	130	26
0 7	80 [S]	8M30	192	24
0 9	100	8M50	256	32
1 0	125	8M70	304	38

Shaft dimensions

Size	Shaft $\varnothing h6 \times$ length	Key
30	6 x 15	2x2x12
40	10 x 27	3x3x25
60 [S]	14 x 35	5x5x28
80 [S]	18 x 45	6x6x40
100	22 x 45	6x6x40
125	30 x 55	8x7x40

Basic length + stroke = total length

ELZ 40 1 0 0 0 0 3 1 01500

Pos. 1 2 3 4 5 6 7

Sample ordering code:

ELZ 40 with standard body profile, standard carriage, coupling claw on one side, 1275 mm stroke.



Positioning system ELZ 30, 40, 60, 80, 80S, 100, 125

Dimensions (mm)

Belt drive with two carriages moving in opposite directions

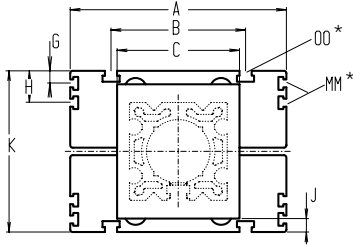
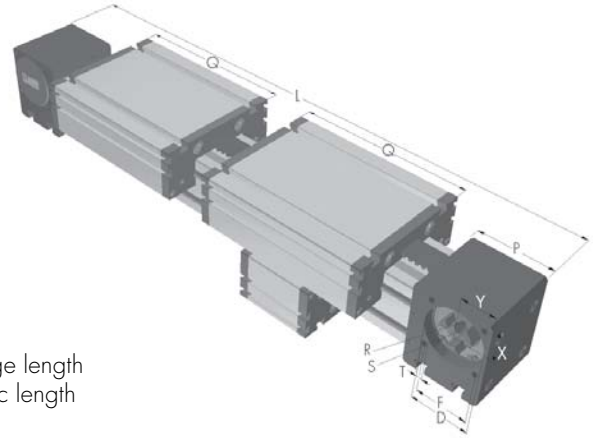
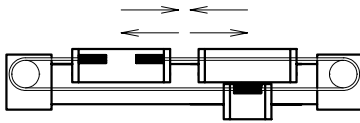

Increasing the carriage length will increase the basic length by the same amount.

*For slide-nuts refer to chapter 2.2 page 2

Size	Basic length L	A	B	C	D	F	G	H	J	K	MM for	OO for	P	Q	T	X	Y	Basic weight	Weight per 100 mm
ELZ 30	250	70	56	42	28	25	-	-	5	52	-	M 6	36	82	M 4	16	16	1,2 kg	0,13 kg
ELZ 40	350	100	66	58	37	32	-	-	6	70	-	M 6	49	122	M 5	20,5	20,5	2,8 kg	0,24 kg
ELZ 60	460	144	96	80	47	42	-	-	8	98	-	M 8	59	168	M 6	27	27	7,4 kg	0,62 kg
ELZ 80	570	170	117	100	68	60	10	30	19	140	M 6	M10	90	194	M 8	39	39	15,0 kg	1,00 kg
ELZ 80S	610	190	126	100	68	60	12,5	30	21	142	M 6	M 8	90	214	M 8	39	39	17,0 kg	1,00 kg
ELZ 100	830	230	155	130	90	80	-	29	24	178	M10	M10	110	300	M10	50	50	34,0 kg	1,60 kg
ELZ 125	990	295	200	160	110	100	-	30	25,5	216	M10	M12	130	365	M10	60	60	53,5 kg	2,10 kg

Choice of guide body profile:

- 0** (0) Standard (1) stainless guide rods (2) stainless guide rods and screws

Choice of carriages:

- 0** (0)



For standard carriage length see 'Q' in table. The carriages can be delivered in any non-standard length upon request; the longer the carriage, the greater the load capacity.



Top and bottom carriages are rigidly joined, thus enabling higher loads to be applied. This increases the basic length by 24 - 48 mm. For thickness of jointing plate refer to chapter 1.2 page 6.

Coupling - shaft mounting:

- 0**

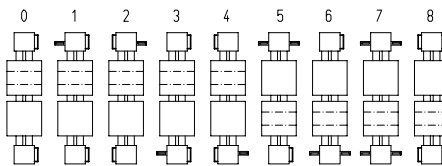

Version 8 is the same as 0, but with double sided coupling claw.

The standard version is supplied without shaft. A shaft can be retrofitted by inserting in the pulley bore and securing with 2 locking rings or tension sets (size 100 and 125).

Belt table

Code No.	Size	Belt	mm/rev.	Number of teeth
0 1	30	3M12	75	25
0 3	40	5M15	100	20
0 4	60 (S)	5M25	130	26
0 7	80 (S)	8M30	192	24
0 9	100	8M50	256	32
1 0	125	8M70	304	38

Shaft dimensions

Size	Shaft ϕ h6 x length	Key
30	6 x 15	2x2x12
40	10 x 27	3x3x25
60 (S)	14 x 35	5x5x28
80 (S)	18 x 45	6x6x40
100	22 x 45	6x6x40
125	30 x 55	8x7x40

Basic length + stroke = total length

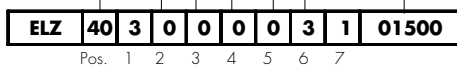

For combination kits and connecting elements refer to chapter 2.2

Sample ordering code:

ELZ 40, right/left hand with standard body profile, standard carriage, coupling claw on one side, 1150 mm stroke.