

# Positioning system ELZG 30, 40, 60, 80, 80S

Dimensions (mm)

## Belt drive

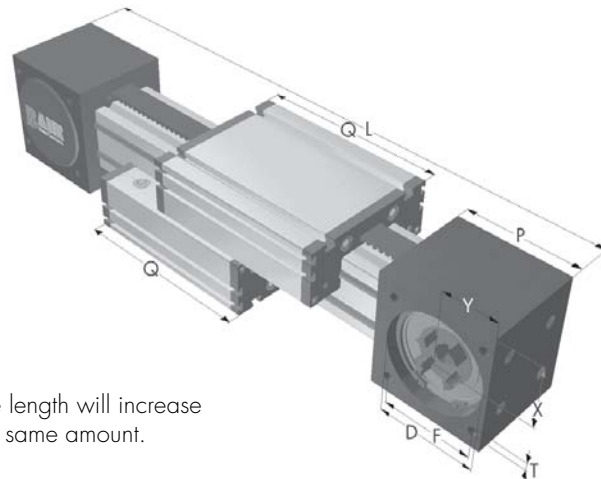
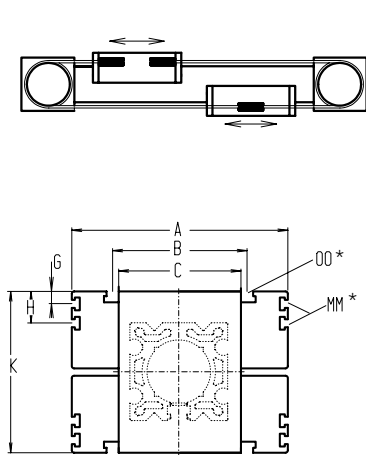

Increasing the carriage length will increase the basic length by the same amount.

3.1



\*For slide-nuts refer to chapter 2.2 page 2

Size	Basic length L	A	B	C	D	F	G	H	K	MM for	OO for	P	Q	T	X	Y	Basic weight	Weight per 100 mm
ELZG 30	195	70	56	48	47	42	-	-	52	-	M 6	55	82	M 6	26	27	1,1 kg	0,13 kg
ELZG 40	265	100	66	60	55	55	-	-	70	-	M 6	70	122	M 6	35	33	4,0 kg	0,29 kg
ELZG 60	365	144	96	88	80	70	-	-	98	-	M 8	95	168	M 8	49	46	10,3 kg	0,65 kg
ELZG 80	460	170	117	118	110	100	10	30	140	M 6	M 10	130	194	M 10	70	60	23,5 kg	1,15 kg
ELZG 80S	480	190	126	118	110	100	12,5	30	142	M 6	M 8	130	214	M 10	70	60	24,5 kg	1,15 kg

### Choice of guide body profile:

- 0** (0) Standard (1) stainless guide rods (2) stainless guide rods and screws (3) stainless guide rods, rollers and screws

### Choice of carriages:



For standard carriage length see 'Q' in table. The carriages can be delivered in any non-standard length upon request; the longer the carriage, the greater the load capacity.

### Coupling - shaft mounting:

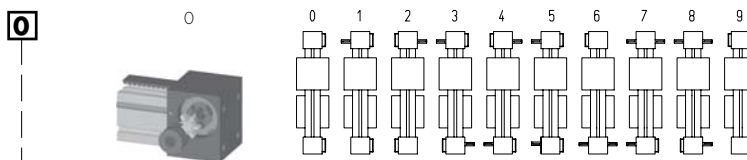

Version 9 is the same as 0, but with double sided coupling claw.

The standard version is supplied without shaft. A shaft can be retrofitted by inserting in the pulley bore and securing with 2 locking rings or tension sets (size 80).

### Belt table

Code No.	Size	Belt	mm/rev.	Number of teeth
0 1	30	3M12	120	40
0 3	40	5M15	160	32
0 4	60	5M25	220	44
0 7	80 [S]	8M30	320	40

### Shaft dimensions

Size	Shaft Ø h6 x length	Key
30	6 x 15	2x2x12
40	14 x 35	5x5x28
60	18 x 45	6x6x40
80 [S]	22 x 45	6x6x40

Basic length + stroke = total length

ELZG	40	1	0	0	0	0	3	1	01500
Pos.	1	2	3	4	5	6	7		

For combination kits and connecting elements refer to chapter 2.2

Sample ordering code:

ELZG 40, standard body profile, standard carriage and coupling claw on one side, 1235 mm stroke.

