

Turning Ideas Into Engineered Solutions

# KAYDON

## RING & SEAL, INC.



**K-CBS Series  
Circumferential Barrier Seals**

Kaydon's high performance circumferential barrier seals back up DGS systems with performance & economy.

**KAYDON RING & SEAL, INC.**

## KAYDON

### K-CBS Circumferential Barrier Seals

## Why Use K-CBS Circumferential Barrier Seals?

First of all, they protect the environment. Injected with air or nitrogen, they provide a safe buffer from both DGS system and process gas. In the face of ever more stringent EPA standards, using barrier seals makes sense because they provide the most conservative leakage rates available today.

Second, they guard against process gas contamination by minimizing oil transfer from the bearing cavity to the DGS system. The K-CBS is especially effective because it is a contact seal. Unlike labyrinth designs, the K-CBS design does not require a small radial clearance between the sealing element and a shaft sleeve. As a result, the migration of oil is effectively halted and your DGS system performs at its optimum.

Third, they provide a secure defense in case of emergency shutdown situations. Proven in the field and exhaustively tested in the lab, when the K-CBS was subjected to a DGS breakdown, all of its seal elements remained intact and outbound compressor gas was effectively contained. You can count on a generous 15-minute window to shut systems down safely.

Best of all, the K-CBS costs far less than a fully redundant DGS add-on system. It fits behind any dry gas seal and its service life is approximately 4 years in normal operation.

Please note: All data, statements and claims contained in this brochure are correct, but are to be considered as general information only. To obtain design and performance particulars for your applications, please contact a Kaydon Ring & Seal Application Engineer.

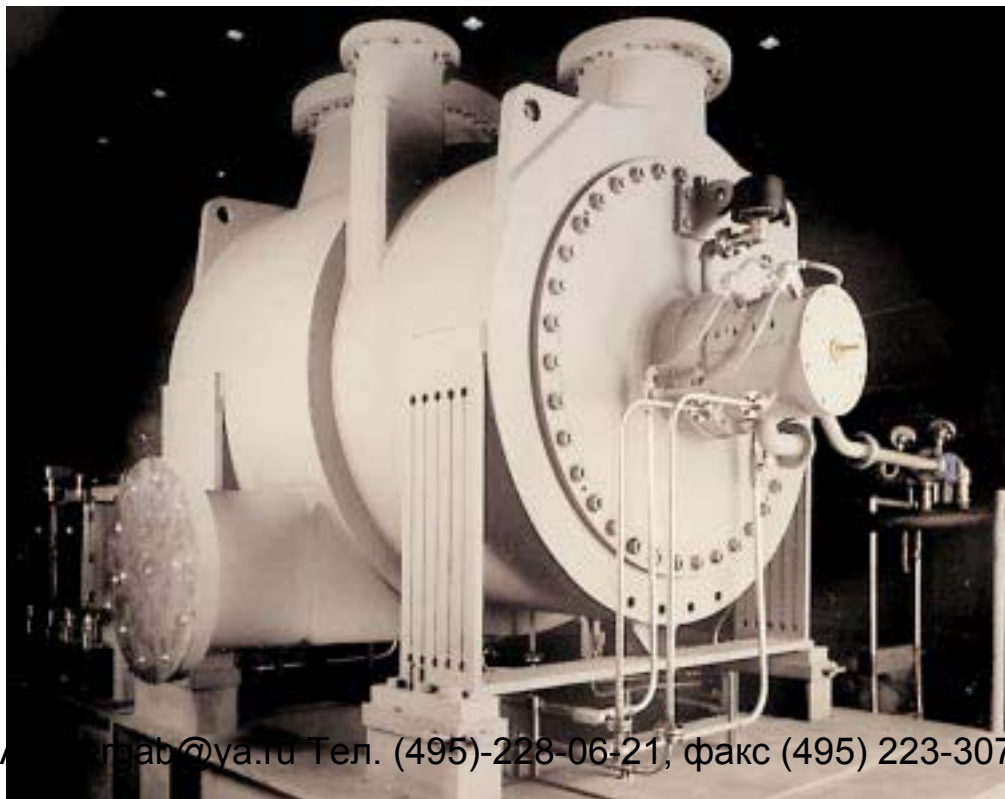

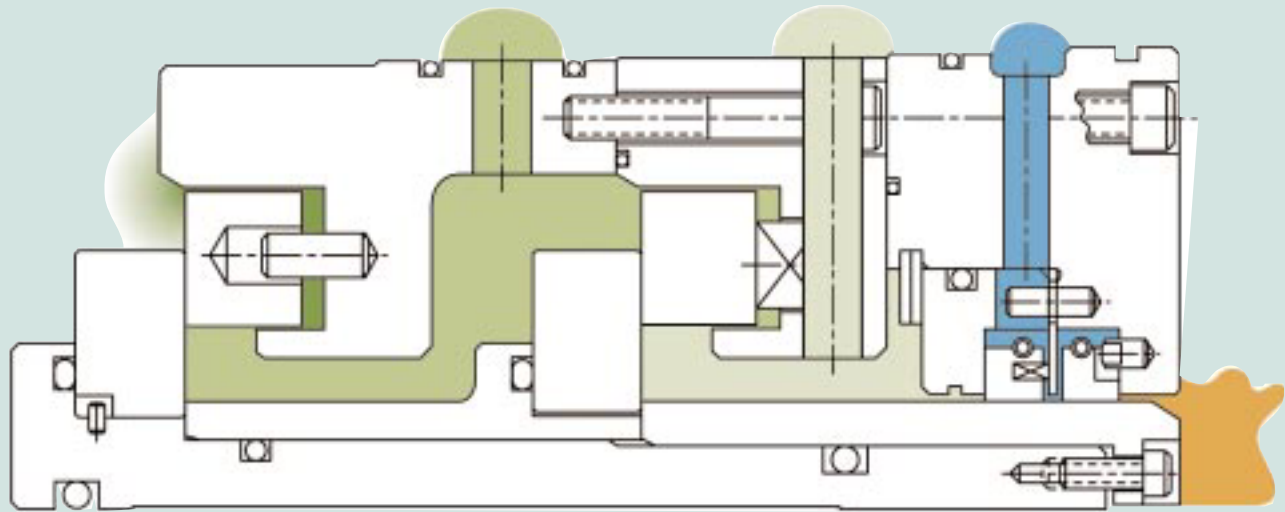

## The K-CBS Performance Is Unmatched In Its Class!

Shown in this illustration with a “generic” DGS, Kaydon’s K-CBS Circumferential Barrier Seal provides positive, contact, sealing interfaces to both DGS system gas and bearing oil. Each of the two circumferential seal rings is segmented with overlapping joints; each has an external garter spring and several internal axial springs; each is “locked” against rotation with specially-designed dowel pins. The nitrogen or air buffer leaks at a controlled, low rate towards the DGS vent and the bearing cavity. During a DGS upset, the bearing side circumferential seal ring takes the full pressure load imposed on it from the DGS. Because this is a contact seal ring, leakage control is excellent, and debris is contained.

These three modes of operation with clearance labyrinth seals are shown below. In each case, gas or oil loss would be far lower with the K-CBS Circumferential Barrier Seal.

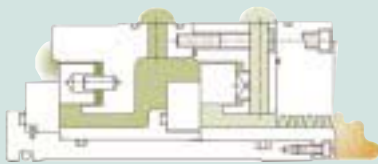

Unbuffered labyrinth or ring seals offer little resistance to DGS vent gas migration to the bearing drain and vent.

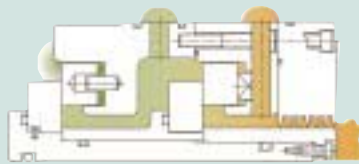

Bearing oil has a clear, open pathway to critical DGS sealing surfaces with an unbuffered laby or seal ring.



During a DGS system upset, debris can pass through a laby or ring clearance seal to the bearing cavity.

## KAYDON

### K-CBS Circumferential Barrier Seals

## Engineered Advantages

The K-CBS series circumferential barrier seal is a lightly loaded contact seal with over 4 years of wear life in many applications. It takes up a minimum amount of space in the compressor. Typically, they are less than 1.50 inches long. Circumferential barrier seals have two carbon seal rings which are spring loaded and have overlapping joints. They contact a hard-faced shaft or sleeve and are buffered with a “safe” gas, such as nitrogen or air, at low pressure (5-15 PSIG). They have leakage rates of about 0.1 SCFM per inch of diameter.

The segmented carbon seal ring used in the K-CBS type is a development of the sealing technology Kaydon uses for high performance main-shaft bearing seals in aircraft turbine engines. With the advent of low-leakage, controlled lift dry gas seals in the late 1970s, the need to have an effective and safe emergency breakdown seal became of prime importance to the industrial compressor industry. Kaydon Ring & Seal responded by modifying aircraft circumferential seals to specifically satisfy industrial customer applications. The K-CBS is specially engineered to provide exceptional performance while accommodating the particular design requirements of industrial compressors.

## Backs Up Any Dry Gas Seal

If you have an application for the K-CBS circumferential barrier seal, do not hesitate to contact us with specific application criteria and configuration questions. Utilizing CAD/CAM links, we ensure a precision fit to each application from our entire stock. Hundreds of our seals have been installed in the field behind the dry gas seals of several manufacturers—including, of course, our own! Seal housing outer diameter and sleeve/shaft profiles can be adapted to any reasonable size configuration. Our current field applications run from 2 to 8.5 inches in diameter, but Kaydon’s standard designs can be economically customized for any compressor which uses a dry gas seal.

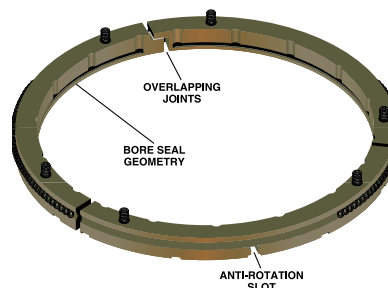
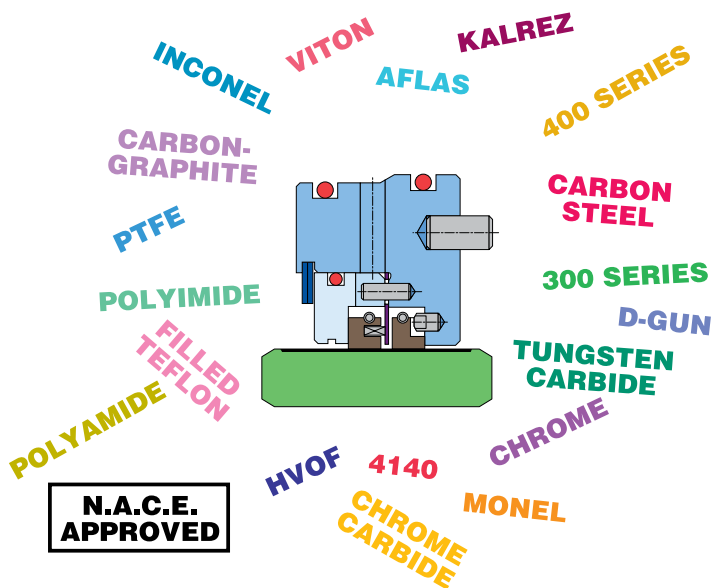

Overlapping joints, specialized bore sealing geometry and other features combine to produce an effective contact seal.

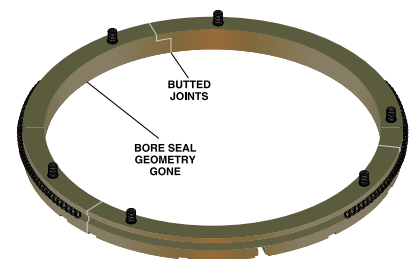

Designed failure mode of K-CBS produces a carbon bushing seal with controlled leakage.

< Wide range of materials available for K-CBS Circumferential Barrier Seals. Typical seal consists of 300 Series housings, pins and retaining rings; high-temperature resistant carbon-graphite seal rings; Viton or equivalent “O”-rings. Sleeves are hard-coated with tungsten carbide or chrome.

## Performance Data

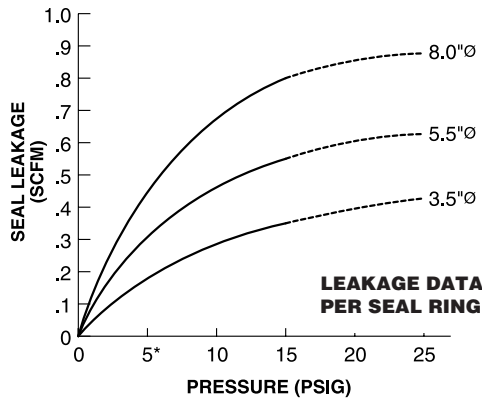

Leakage increases with imposed  $\Delta P$  over the normal operating range of 5-15PSIG. Operation over 15 PSIG is not recommended since wear rates may be higher than expected; nor should the seal be run with lower than about 5 PSIG since oil migration control will be ineffective. At 15 PSIG, demonstrated leakage rate is 0.1 SCFM/inch of sleeve diameter. This factor is 0.084 SCFM/inch at 10 PSIG; 0.055 SCFM /inch at 5 PSIG.

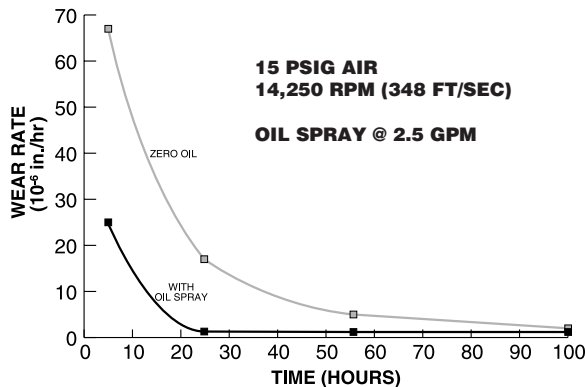

Kaydon's circumferential barrier seal is partially balanced in the radial direction, which minimizes its imposed total load against the rotating sleeve or shaft. As a result, there is a small net inward radial force that contributes to wear of the carbon-graphite in the bore of the seal ring. Our tests demonstrate that the wear rate is highest during the "break-in" cycle of seal operation—a running film is formed between the carbon and hard facing that minimizes subsequent carbon loss. In addition, the presence of a small amount of lubricating fluid, such as from the air/oil mist in a bearing drain chamber, reduces the wear rate significantly. Please note that the "oil spray" indicated on the curve did not migrate past the K-CBS seal into the DGS chamber.

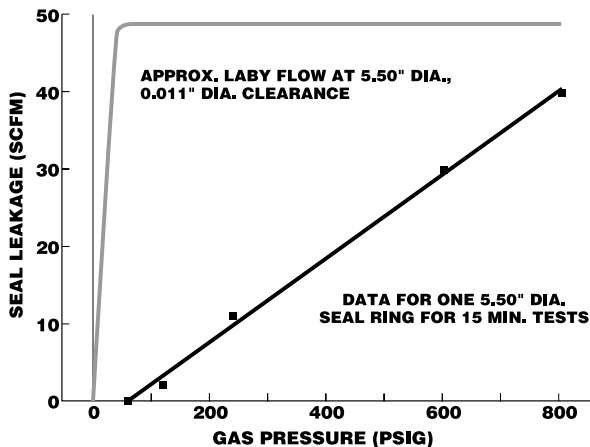

To demonstrate the advantages of the K-CBS Circumferential Barrier Seal in "breakdown" mode, we imposed several high pressures on the seals from the DGS side for approximately 15 minutes each. The results show an almost linear increase in leakage control with pressure. Even at 800 PSIG, the leakage rate through the K-CBS was lower than that of an equivalent-size labyrinth clearance seal. At the pressures over 200 PSIG, there was excessive carbon wear and the sleeve outer diameters were scuffed. However, the seal rigs remained intact—no debris of any material size could have passed through to the bearing cavity. In addition, the K-CBS housings were not damaged during any of our tests. Proper sizing of inboard labyrinths and vent ports will, of course, minimize the imposed  $\Delta P$  on the K-CBS.



## KAYDON

### K-CBS Circumferential Barrier Seals

## Cartridge Configurations

A Sleeve Nominal	D Housing O.D. Min.	G Housing Axial Length	Estimated Nitrogen Leakage 15 PSI ΔP SCFM/Ass'y	Seal Maximum Speed, RPM	K-CBS Series Catalog Number
2.0000	4.075	1.000	0.40	57,300	2200
2.2500	4.330	1.000	0.45	50,900	2225
2.5000	4.585	1.000	0.50	45,800	2250
2.7500	4.840	1.000	0.55	41,700	2275
3.0000	5.165	1.062	0.60	38,200	2300
3.2500	5.420	1.062	0.65	35,300	2325
3.5000	5.745	1.062	0.70	32,700	2350
3.7500	5.930	1.062	0.75	30,600	2375
4.0000	6.245	1.125	0.80	28,600	2400
4.2500	6.500	1.125	0.85	27,000	2425
4.5000	6.750	1.125	0.90	25,500	2450
4.7500	7.005	1.125	0.95	24,100	2475
5.0000	7.275	1.188	1.00	22,900	2500
5.2500	7.525	1.188	1.05	21,800	2525
5.5000	7.785	1.188	1.10	20,800	2450
5.7500	8.035	1.188	1.15	19,900	2575
6.0000	8.485	1.250	1.20	19,100	2600
6.2500	8.735	1.250	1.25	18,300	2625
6.5000	8.995	1.250	1.30	17,600	2650
6.7500	9.245	1.250	1.35	17,000	2675
7.0000	9.505	1.312	1.40	16,400	2700
7.2500	9.755	1.312	1.45	15,800	2725
7.5000	10.015	1.312	1.50	15,300	2750
7.7500	10.265	1.312	1.55	14,800	2775
8.0000	10.525	1.375	1.60	14,300	2800
8.2500	10.775	1.375	1.65	13,900	2825
8.5000	11.035	1.375	1.70	13,500	2850
8.7500	11.285	1.375	1.75	13,100	2875
9.0000	11.545	1.438	1.80	12,700	2900
9.2500	11.795	1.438	1.85	12,400	2925
9.5000	12.055	1.438	1.90	12,100	2950
9.7500	12.305	1.438	1.95	11,800	2975

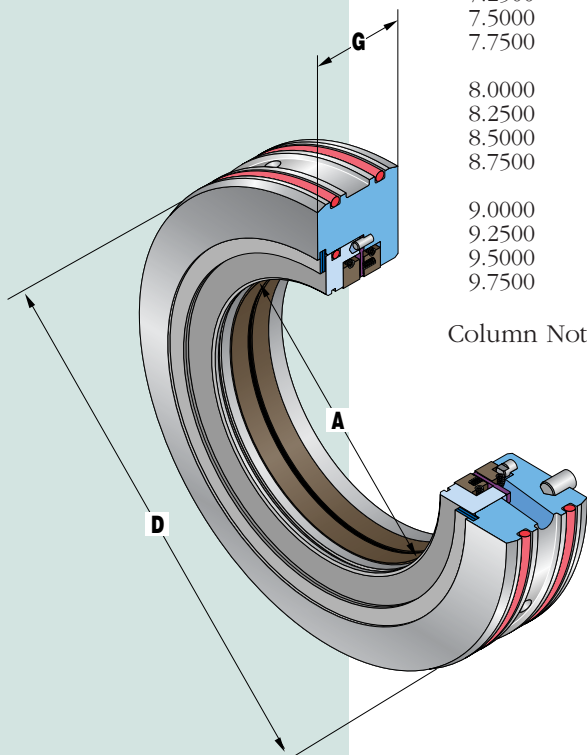

#### Column Notes:

- Dimension A: Listed is the nominal sleeve diameter; required tolerance is +0.0000/-0.0005.
- Dimension D: Listed is the minimum housing O.D. possible with the selected sleeve ("A"); maximum outer diameter may be up to 2.000" larger. Customer is to choose desired housing O.D.
- Dimension G: Listed is the seal cartridge housing axial length.
- Estimated Leakage: Actual leakage will vary with ΔP, from 5 PSID minimum to 15 PSID maximum. Operation outside this pressure range may produce high oil and buffer gas leakage, and may accelerate seal wear.
- Seal Max. Speed: Kaydon's Circumferential Barrier Seal is designed to run at speeds faster than most compressors at the same shaft diameter.
- Kaydon Cat. No.: To provide proper oil exclusion, the Kaydon Circumferential Barrier Seal is directional. For a beam-style compressor, both a CC and CW seal are required. Rotational direction is viewed from the bearing end of the compressor.

Puller holes, pins, or holes on either process or bearing side can be supplied. "O"-rings are 75 Durometer Viton or equivalent unless otherwise requested. 0.103" "O"-rings are used to C/N 2575; 0.139" "O"-rings for larger sizes. Customer's gas supply ports vary from 0.188" to 0.375" diameter. Please see "Engineering Information Sheet" for further details.



## Flange Mount Configurations

A Nominal	D O.D. Min.	G Axial Length	L Thickness	Estimated Leakage 15 PSI ΔP SCFM/Ass'y	Seal Speed, RPM	K-CBS Series Catalog Number
2.0000	3.470	0.875	0.25	0.40	57,300	3200
2.2500	3.725	0.875	0.25	0.45	50,900	3225
2.5000	3.980	0.875	0.25	0.50	45,800	3250
2.7500	4.240	0.875	0.25	0.55	41,700	3275
3.0000	4.565	0.938	0.38	0.60	38,200	3300
3.2500	4.820	0.938	0.38	0.65	35,300	3325
3.5000	5.140	0.938	0.38	0.70	32,700	3350
3.7500	5.330	0.938	0.38	0.75	30,600	3375
4.0000	5.645	1.000	0.50	0.80	28,600	3400
4.2500	5.900	1.000	0.50	0.85	27,000	3425
4.5000	6.150	1.000	0.50	0.90	25,500	3450
4.7500	6.405	1.000	0.50	0.95	24,100	3475
5.0000	6.675	1.062	0.63	1.00	22,900	3500
5.2500	6.925	1.062	0.63	1.05	21,800	3525
5.5000	7.185	1.062	0.63	1.10	20,800	3550
5.7500	7.435	1.062	0.63	1.15	19,900	3575
6.0000	7.820	1.125	0.75	1.20	19,100	3600
6.2500	8.070	1.125	0.75	1.25	18,300	3625
6.5000	8.330	1.125	0.75	1.30	17,600	3650
6.7500	8.580	1.125	0.75	1.35	17,000	3675
7.0000	8.905	1.188	0.88	1.40	16,400	3700
7.2500	9.155	1.188	0.88	1.45	15,800	3725
7.5000	9.415	1.188	0.88	1.50	15,300	3750
7.7500	9.665	1.188	0.88	1.55	14,800	3775
8.0000	9.924	1.250	1.00	1.60	14,300	3800
8.2500	10.175	1.250	1.00	1.65	13,900	3825
8.5000	10.435	1.250	1.00	1.70	13,500	3850
8.7500	10.685	1.250	1.00	1.75	13,100	3875
9.0000	10.945	1.312	1.13	1.80	12,700	3900
9.2500	11.195	1.312	1.13	1.85	12,400	3925
9.5000	11.455	1.312	1.13	1.90	12,100	3950
9.7500	11.705	1.312	1.13	1.95	11,800	3975

### Column Notes:

- Dimension A: Listed is the nominal sleeve diameter; required tolerance is +0.0000/-0.0005.
- Dimension D: Listed is the minimum housing O.D. possible with the selected sleeve ("A"); maximum outer diameter may be up to 2.000" larger. Customer is to choose desired housing O.D.
- Dimension G: Listed is the seal cartridge housing axial length from the flange.
- Dimension L: Flange thickness—mounting hole diameter and patterns may vary with seal size.
- Estimated Leakage: Actual leakage will vary with ΔP, from 5 PSID minimum to 15 PSID maximum. Operation outside this pressure range may produce high oil and buffer gas leakage, and may accelerate seal wear.
- Seal Max. Speed: Kaydon's Circumferential Barrier Seal is designed to run at speeds faster than most compressors at the same shaft diameter.
- Kaydon Cat. No.: To provide proper oil exclusion, the Kaydon Circumferential Barrier Seal is directional. For a beam-style compressor, both a CC and CW seal are required. Rotational direction is viewed from the bearing end of the compressor.

Flange may be on either bearing or process side of seal, with integral jacking holes. "O"-rings are 75 Durometer Viton or equivalent unless otherwise requested. 0.103" "O"-rings are used to C/N 3575; 0.139" "O"-rings for larger sizes. Customer's gas supply ports vary from 0.188" to 0.375" diameter. Please see "Engineering Information Sheet" for further details.

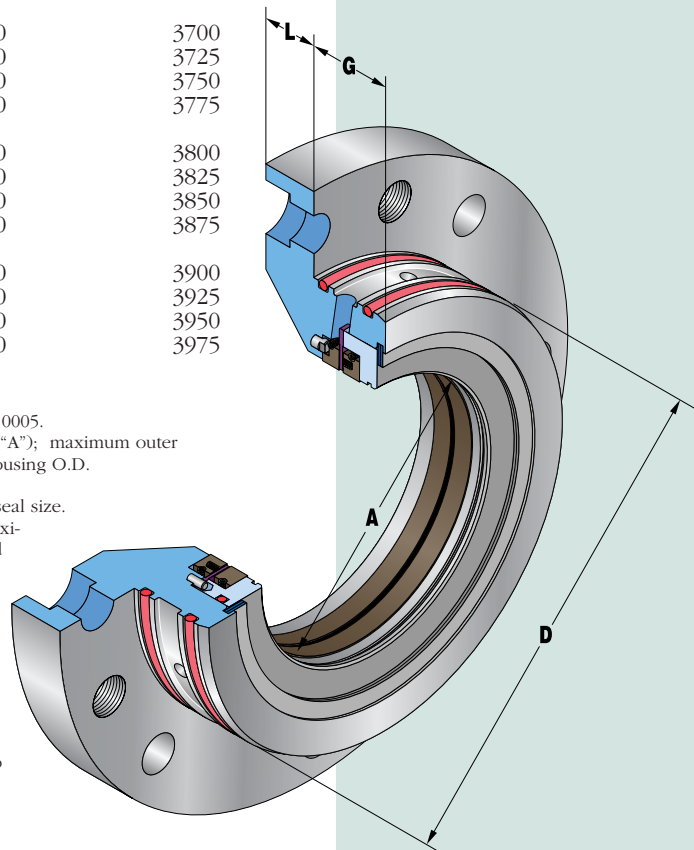

KAYDON

K-DGS Dry Gas Seals



## No Other Performs Better!

DGS Seals are computer designed to optimize dynamic response to axial runout, tilt and misalignment. They provide consistent, reliable performance with sealing and buffer gas flows of only 0.3 to 0.5 SCFM per inch of rotating seal diameter. They can be specified in a wide range of materials for specific corrosion or strength requirements. Standard materials for internal components: silicon carbide shoulders; carbon graphite seal rings; "O"-rings of Viton or Kalrez; stainless steel rotors and housings; NACE-approved throughout.

For more information which addresses your specific application, contact Kaydon today!

Patented tapered lands provide hydrodynamic lift. As RPM increases, so does lift force, providing a stiff gas film to support the loads arising in dynamic tracking or rotor movements.

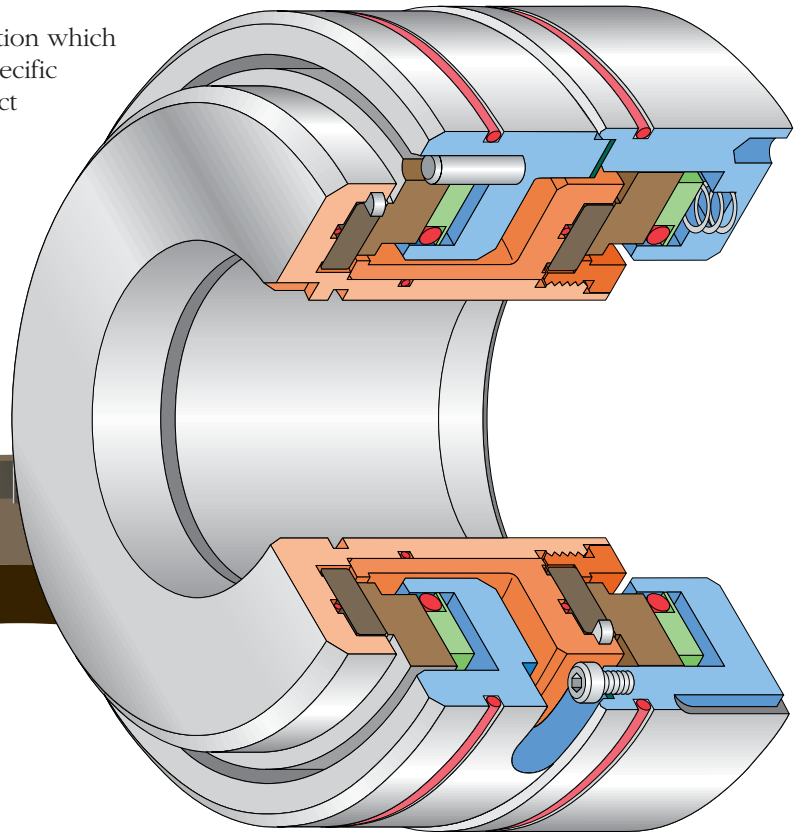

Turning Ideas Into Engineered Solutions

**KAYDON**  
RING & SEAL, INC.

P.O. Box 626, Baltimore, MD 21203 USA

Phone: 410-547-7700 ■ FAX: 410-576-9059

www.kaydoncorp.com ■ E-mail: kaydon@kaydonringandseal.com

8/98-0005868-39393-110011 © Kaydon Ring & Seal 1998. All rights reserved.