

Motors and control units



Accessories

Rotary current techniques 1 - 3

AC worm gear motor

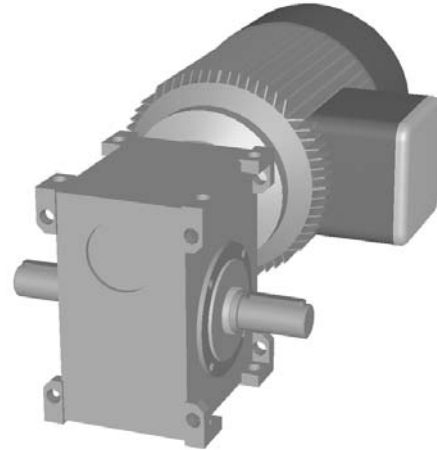
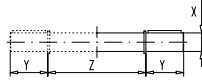
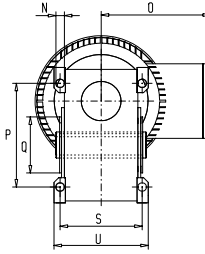
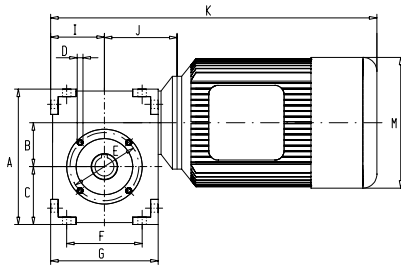

Code-No.	Power	Type	A	B	C	D	E	F	G	I	J	K	M	N	O	P	Q	S	U	X	Y	Z		
E 50040	180 W	MVU 35-63	118	35	52	M 6	55	70	102	51	71	312	124	7	108	85	45	72	84	14	30	90		
E 50041	370 W	MVU 35-71	118	35	52	M 6	55	70	102	51	71	332	139	7	116	85	45	72	84	14	30	90		
E 50042	180 W	MVU 47-63	145	47	62	M 6	73	80	114	57	77	324	124	9	108	110	60	85	100	20	40	104		
E 50043	370 W	MVU 47-71	145	47	62	M 6	73	80	114	57	77	344	139	9	116	110	60	85	100	20	40	104		
E 50044	180 W	MVU 60-71	180	60	75	M 8	85	94	140	70	92	372	139	9	116	134	70	104	120	25	50	128		
E 50045	550 W	MVU 60-80	180	60	75	M 8	85	94	140	70	92	396	157	9	124	134	70	104	120	25	50	128		
E 50046	750 W	MVU 85-80	245	85	105	M10	115	145	202	101	123	458	157	11	124	190	95	120	142	35	65	157		
E 50060	motor brake	up to size 71																						
E 50061	motor brake	up to size 80																						

Voltage/Frequency:
230\400 V/50Hz
System of protection: IP 55
Insulation:
Suitable for frequency converter operation.

Motor protection:
With frequency converter operation, it is recommended to protect the motor by means of temperature probes built into the winding (posistors or thermal switches).
This protection is dependent on the temperature and protects the motors against overheating of the winding both due to overload and due to frequently changing loads or insufficient cooling.

Brakes:
The motors listed are also available with brake. The built-in spring-actuated single-disc brake is a safety brake that brakes by means of spring power when the voltage is disconnected. The DC voltage is generated by a rectifier in the terminal box of the motor. The motor may only be switched on in connection with the brake

Power	rpm	i	M _{permanent}	M _{start}	Type	Weight	Rated current
180 W	20 min ⁻¹	70:1	36 Nm	34 Nm	MVU 47-63	6,8 kg	0,6 A
	28 min ⁻¹	50:1	23 Nm	32 Nm	MVU 35-63	5,7 kg	
	35 min ⁻¹	40:1	24 Nm	27 Nm			
370 W	20 min ⁻¹	70:1	72 Nm	70 Nm	MVU 60-71	11,5 kg	1,2 A
	23 min ⁻¹	60:1	95 Nm	70 Nm			
	28 min ⁻¹	50:1	80 Nm	63 Nm			
	28 min ⁻¹	50:1	52 Nm	63 Nm	MVU 47-71	9,5 kg	
	35 min ⁻¹	40:1	50 Nm	55 Nm			
	47 min ⁻¹	30:1	52 Nm	45 Nm			
	56 min ⁻¹	25:1	45 Nm	42 Nm			
	70 min ⁻¹	20:1	38 Nm	36 Nm			
	93 min ⁻¹	15:1	30 Nm	32 Nm			
	140 min ⁻¹	10:1	20 Nm	25 Nm	MVU 35-71	8,2 kg	
	47 min ⁻¹	30:1	26 Nm	45 Nm			
	56 min ⁻¹	25:1	28 Nm	42 Nm			
70 min ⁻¹	20:1	30 Nm	36 Nm				
93 min ⁻¹	15:1	26 Nm	32 Nm				
140 min ⁻¹	10:1	20 Nm	25 Nm				
750 W	20 min ⁻¹	70:1	116 Nm	140 Nm	MVU 70-80	17,5 kg	2 A
	23 min ⁻¹	60:1	150 Nm	140 Nm			
	28 min ⁻¹	50:1	163 Nm	126 Nm			
	35 min ⁻¹	40:1	110 Nm	110 Nm	MVU 60-80	15 kg	
	47 min ⁻¹	30:1	108 Nm	90 Nm			
	56 min ⁻¹	25:1	95 Nm	84 Nm			
	70 min ⁻¹	20:1	80 Nm	72 Nm			
	93 min ⁻¹	15:1	60 Nm	63 Nm			
140 min ⁻¹	10:1	40 Nm	50 Nm				



3.2

Accessories

Rotary current techniques 2 - 3

Pulse generator

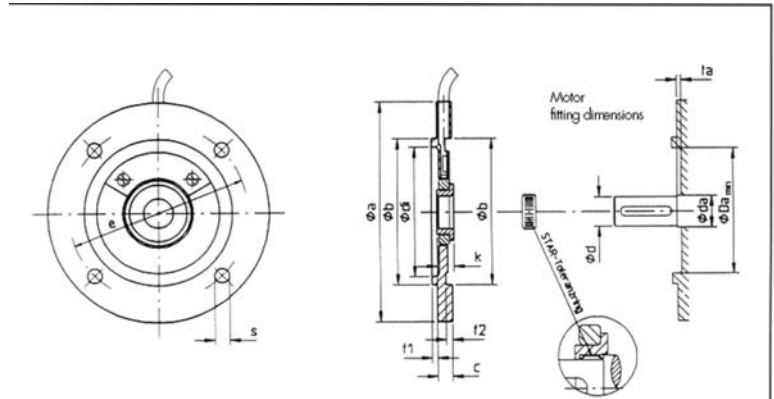
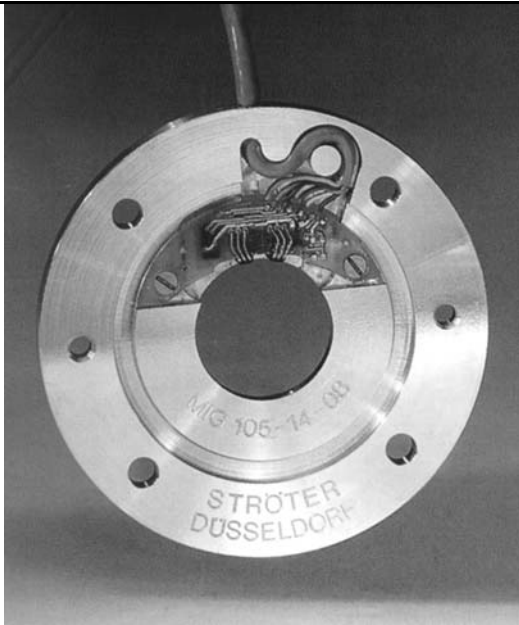

Magnetic Pulse Generator

An "intelligent" intermediate flange has been developed which significantly simplifies the measurement of motor speed, direction of rotation and the connection with higher control systems. What has only been possible by complicated and expensive mounting into driving systems up to now can now be done in an easy and economical way - both in new and existing installations.

The magnetic pulse generator is designed as an intermediate flange which is simply installed between the motor and machine flange. This makes the integration of incremental position encoders into driving systems much easier - whether they are applied as positioning controllers, for speed measurement or e.g. for dosing control or synchronization control.

The advantages of the new magnetic pulse generator are:

1. Compact design: Depending on size the space required by the flange thickness in only 7, 12 or 15 mm.
2. Easy assembly: The flange with its sensors is directly fastened to the motor; the magnet ring is stuck onto the motor shaft.
3. Appropriate for all IEC flange motors, sizes 56 to 225.
4. Suitable for other flange connections as well, e.g. those of D.C. motors, hydraulic motors and compressed-air motors, pumps, etc.
5. No mechanical modifications are required for assembly.
6. A proven and precise measuring principle: two Hall sensors receive the signals for speed & direction of rotation. This ensures a precise measurement with no wearing parts or maintenance required.
7. A reasonably priced solution which is also suitable for economical retrofitting of existing drives.
8. Installation: between motor and machine flange; mechanical protection is thus guaranteed; system of protection IP 67.
9. Universal HTL signal for all usual evaluations (PNP, NPN, PNP-NPN, RS422).
10. The monitoring system can be located at a distance of up to 1.000m from the pulse generator.
11. The number of pulses can be duplicated or quadruplicated by means of a downstream electronic system.
12. SMD-type generator electronics: short-circuit-proof, protected against polarity reversal and provided with overvoltage protection; completely integrated in the flange.

a	b	c	d1	e	f1	f2	k	s
80	50	10	42	65	2.5	3	9	6
90	60	7	52	75	2.5	3	8	7
105	70	7	62	85	2.5	3	8	7
120	80	7	70	100	3	3.5	8	7
140	95	7	85	115	3	3.5	8	9
		10					11	
160	110	7	100	130	3.5	4	8	9
		10					11	
200	130	10	120	165	3.5	4	11	11
250	180	12	170	215	4	5	13	13
300	230	12	220	265	4	5	13	13
350	250	12	240	300	5	6	13	17

d x length	da	ta	Da
∅ 9 x 20	10	1	22
∅ 11 x 23	12	2	52
∅ 9 x 20	10	2	63
∅ 14 x 30	15	2	63
∅ 9 x 20	10	2	63
∅ 11 x 23	12	2	63
∅ 19 x 40	20	2	63
∅ 11 x 23	12	2	85
∅ 14 x 30	15	2	85
∅ 24 x 50	25	3	85
∅ 14 x 30	15	2	90
∅ 19 x 40	20	2	90
∅ 24 x 50	25	3	90
∅ 28 x 60	30	3	90
∅ 19 x 40	20	2	90
∅ 24 x 50	25	3	90
∅ 28 x 60	30	3	90
∅ 28 x 60	30	3	90
∅ 38 x 80	40	3	120
∅ 42 x 110	45	3	120
∅ 48 x 110	50	3	120

Flange	Shaft	deliverable number of pulses ¹																						
		1	2	4	5	6	7	8	9	10	11	12	15	16	20	25	30	40	50	80	100	200		
∅ 80	∅ 9	X		X	X	X	X	X																
∅ 90	∅ 11	X		X	X	X	X	X					X	X		X ²								
∅ 105	∅ 9	X	X	X	X	X	X																	
	∅ 14	X	X	X	X	X	X					X				X				X	X			
∅ 120	∅ 9	X	X	X	X	X	X																	
	∅ 11	X	X	X	X	X	X																	
	∅ 19	X	X	X	X	X	X																	
∅ 140	∅ 11	X	X	X	X	X	X	X	X	X	X	X	X	X	X	X	X	X	X	X	X	X	X	X
	∅ 14	X	X	X	X	X	X	X	X	X	X	X	X	X	X	X	X	X	X	X	X	X	X	X
	∅ 24	X	X	X	X	X	X	X	X	X	X	X	X	X	X	X	X	X	X	X	X	X	X	X
	∅ 14	X	X	X	X	X	X	X	X	X	X	X	X	X	X	X	X	X	X	X	X	X	X	X
∅ 160	∅ 19	X	X	X	X	X	X	X	X	X	X	X	X	X	X	X	X	X	X	X	X	X	X	X
	∅ 24	X	X	X	X	X	X	X	X	X	X	X	X	X	X	X	X	X	X	X	X	X	X	X
	∅ 28	X	X	X	X	X	X	X	X	X	X	X	X	X	X	X	X	X	X	X	X	X	X	X
	∅ 19	X	X	X	X	X	X	X	X	X	X	X	X	X	X	X	X	X	X	X	X	X	X	X
∅ 200	∅ 24	X	X	X	X	X	X	X	X	X	X	X	X	X	X	X	X	X	X	X	X	X	X	X
	∅ 28	X	X	X	X	X	X	X	X	X	X	X	X	X	X	X	X	X	X	X	X	X	X	X
	∅ 28	X	X	X	X	X	X	X	X	X	X	X	X	X	X	X	X	X	X	X	X	X	X	X
∅ 250	∅ 38	X	X	X	X	X	X	X	X	X	X	X	X	X	X	X	X	X	X	X	X	X	X	X
∅ 300	∅ 42	X	X	X	X	X	X	X	X	X	X	X	X	X	X	X	X	X	X	X	X	X	X	X
∅ 350	∅ 48	X	X	X	X	X	X	X	X	X	X	X	X	X	X	X	X	X	X	X	X	X	X	X

¹ Further numbers available ²⁺³ Additional price

Example for an order:

MIG 105 - 14 - 20

Flange diameter _____
 Shaft diameter _____
 Number of pulses _____

Code-No.
E 66020





- Programmable relay and transistor output (NPN)
- Special U/f line for ventilator and pump operation
- Power range: 1.5 kW - 1x230 VAC / 22 kW- 3x400 VAC (on request)
- Integrated software for:
 - automatic PI-control (pressure, temperature, etc.)
 - positioning controllers
 - digital synchronization control
 - torque limiter
- Serial communication with PC or PLC
- Special software for PLC functions by inquiry

Characteristics

- Flexible software of the controller
- Simple operation due to menu-guided digital parameterization
- High starting torque (170%)
- Silent motor running due to high pulse frequency and vector modulation
- IxR compensation (Boost)
- Programmable ratio of voltage and frequency
- DC braking with static torque
- Safety functions against over- and undervoltage, overcurrent, short circuit, temperature rise (converter and motor)
- Optimum design with small assembly dimensions
- Multiple-motor operation possible
- Options:
 - serial interface RS232 / RS485
 - brake chopper and brake resistance
 - external display, etc.

TheSPEED Commander frequency inverters are used for speed regulation in 3 phase AC motors. It is an universal AC motor controller position setting, serial communication, time interval control and load control. These special programs can be set through the Speed Commander display.

- Vector modulation and 16-bit microprocessor
- Display for:
 - frequency, current, intermediate circuit voltage, parameter values, error messages
- Electrically isolated, PLC-compatible inputs for:
 - frequency control point
 - right-handed rotation
 - left-handed rotation
 - STOP (controlled braking)
 - OFF (dead motor binders)
 - STOP (DC brake)

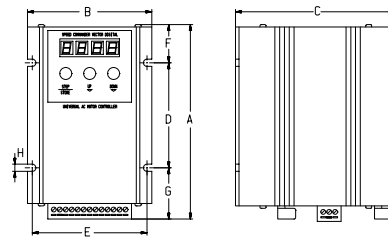

	SC-750	SC-1500
Power supply	1x 230 V ±10% / 50-60 Hz	
Max. motor Power (2- and 4-pole)	0,75 kW	1,5 kW
Output voltage	3x 0-230 V	3x 0-230 V
Output frequency	0-400 Hz	0-400 Hz
Nominal current	3x 4A	3x 7A
Overload capacity	150% für 30 s	150% für 30 s
max. current limit (TRIP)	3x 7,6 A	3x 14 A
Input current	ca. 8 A	ca. 15 A
max. heat loss	50 W	100 W
System of protection	IP 20	IP 20
A	163	298
B	104	104
C	133	133
D	90	140
E	96	96
F	30	86
G	43	72
H	6	6
Code-No.	E 66010	E 66011



Accessories

AC motor
Stepping motor

AC worm gear motor

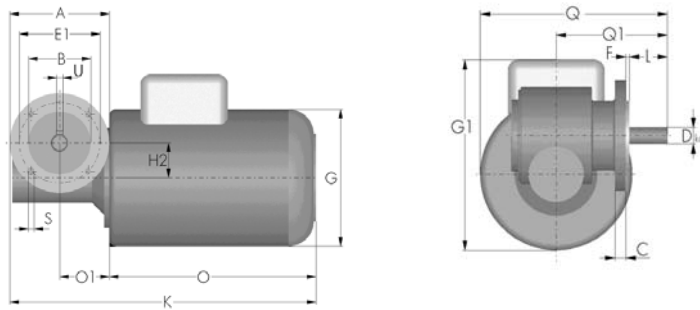

Protection class IP 54, 220/380 V, 50 Hz, from 90 to 1100 W.
Available with electronic disc brake.
Speed 1400 rpm or 2800 rpm.
Reduction gearing options: 5:1, 7:1, 15:1, or 20:1.
Further options on request.

Code-No.	Power	A	B	C	D	E1	F	G	G1	H2	K	L	O	O1	Q	Q1	S	U
E 50001	90 W	140	95	8	18	115	3	112	158	9,6	319	40	168	81	166	116	10,5	6
E 50002	120 W	120	80	8	19	100	3	125	171	40	297	35	187	60	171	102	7	6
E 50003	180 W	120	80	8	19	100	3	125	171	40	297	35	187	60	171	102	7	6
E 50004	250 W	120	80	8	19	100	3	140	184	40	317	60	207	60	184	102	7	6
E 50005	370 W	120	80	8	19	100	3	140	184	40	317	60	207	60	184	102	7	6
E 50006	550 W	160	110	12	30	130	3,5	158	204	65	428	60	233	115	204	154	9	8
E 50007	750 W	160	110	12	30	130	3,5	158	204	65	428	60	233	115	204	154	9	8
E 50008	1100 W	160	110	12	30	130	3,5	178	228	65	469	60	274	115	228	154	9	8
E 50100	motor brake	l = lengthening (O)																

Stepping motor with and without feedback control

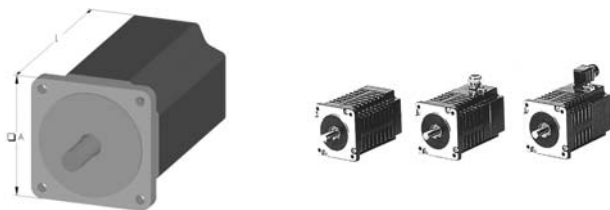

The number of steps of a 3-phase stepping motor can be set to that of a 2-phase stepping motor (200/400 steps per revolution) or 500/1000 steps/revolution. The number of steps per revolution can be multiplied by 10 (to 2000, 4000, 5000 and 10000) using the micro step function.

*Full-step mode with 200 steps per rev.
half step mode with 400 steps per rev.

Code-No.	Type	Nominal voltage	I _w	M ₁ max.	n (M ₁ max.)	□ A	Length	Shaft
3-phase motor								
E 52001	VRDM 368	130 V	2 A	1,5 Nm	300 min ⁻¹	57	116	8 x 21
E 52002	VRDM 368 with brake	130 V	2 A	1,5 Nm	300 min ⁻¹	57	150	8 x 21
E 52003	VRDM 397	130 V	4,4 A	2 Nm	200 min ⁻¹	85	110	12 x 30
E 52004	VRDM 397 with brake	130 V	4,4 A	2 Nm	200 min ⁻¹	85	157	12 x 30
E 52005	VRDM 3910	130 V	5 A	4 Nm	500 min ⁻¹	85	140	12 x 30
E 52006	VRDM 3910 with brake	130 V	5 A	4 Nm	500 min ⁻¹	85	187	12 x 30
E 52007	VRDM 3913	130 V	5 A	6 Nm	150 min ⁻¹	85	170	14 x 30
E 52008	VRDM 3913 with brake	130 V	5 A	6 Nm	150 min ⁻¹	85	217	14 x 30
E 52009	VRDM 31117	325 V	4,1 A	12 Nm	380 min ⁻¹	110	180	19 x 40
E 52010	VRDM 31117 with brake	325 V	4,1 A	12 Nm	380 min ⁻¹	110	233	19 x 40
E 52011	VRDM 31122	325 V	4,75 A	16,5 Nm	250 min ⁻¹	110	228	19 x 40
E 52012	VRDM 31122 with brake	325 V	4,75 A	16,5 Nm	250 min ⁻¹	110	281	19 x 40
2-phase motor *								
E 52030	56 / 2	30/60 V	2 A	0,7 Nm	300 min ⁻¹	56	94	6,35 x 21
E 52031	56 / 2 with brake	30/60 V	2 A	0,7 Nm	300 min ⁻¹	56	134	6,35 x 21
E 52032	87 / 2	60/120 V	5 A	3 Nm	300 min ⁻¹	86	112	10 x 31,5
E 52033	87 / 2 with brake	60/120 V	5 A	3 Nm	300 min ⁻¹	86	157	10 x 31,5
E 52034	87 / 3	60/120 V	5 A	4,5 Nm	300 min ⁻¹	86	144	10 x 31,5
E 52035	87 / 3 with brake	60/120 V	5 A	4,5 Nm	300 min ⁻¹	86	189	10 x 31,5
E 52036	PK 2913	30/60 V	5,6 A	6 Nm	300 min ⁻¹	85	126	14 x 34



3.2



Single-Axis Stepping Motor Controller MPM5111

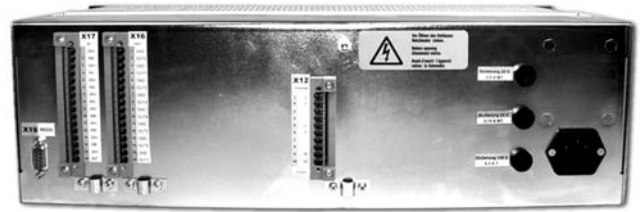

- 19" rack (table top unit)
- from 230 VAC 500 W
- integrated operating terminal with LCD and numeric keypad
- programmable in accordance with ISO standards (DIN 66025)
- suitable for 3-phase stepping motor with max. 130 V/5.5 A
- highest-precision positioning through adjustable microstepping (up to 20,000 steps per revolution)
- optional emergency stop module
- optional automatic holding brake control
- optional additional inputs and outputs (IO-Plus)

Technical Data:

- Power: 500 W
- Height: 133 mm
- Width: 485 mm (19")
- Depth: 275 mm
- Voltage: 230 VAC/50 Hz
- Motor voltage: 130 V
- Motor current: max. 5.5 A (automatic current lowering at standstill)
- Pulse frequency: max. 28,800 Hz
- Digital inputs: 8 for 24 V switching voltage
- Digital outputs: 8 for 24 V switching voltage
- External supply: 24 V/3.2 A (for auxiliary devices such as sensors)
- Temperature range: 0° C to 50° C
- Humidity: max. 85% non-condensing
- Weight: approx. 9 kg
- Class of protection: IP 20 (DIN 40050)
- Display: 2 lines of 16 characters
- Keypad: number keys, 4 function keys, arrow keys

The positioning controller MPM 5111 features these operating modes:

- **Automatic mode:**
 - Start of the specified run-off program
- **Setup mode:**
 - Programming of complex positioning operations for 1 axis (DIN 66025) with G-codes. A list of the available G-codes is found below in the command overview.
 - A program can have a maximum length of 100 lines.
 - Adjustment of parameters
- **Manual operation:**
 - Manual start of reference run
 - Manual operation of axis
 - Setting the 8 digital outputs
 - Status check of 8 digital inputs
- **Online operation (via PC):**
 - Direct execution of G-codes
 - Reading-out and storing of programs

The following parameters can be set by the user:

- Calibration (user units and machine units, 1 - 8,000,000 each)
- Reference run velocity (1 - 28,000 Hz)
- Manual run velocity (1 - 28,000 Hz)
- Positioning velocity (1 - 28,000 Hz)
- Acceleration, deceleration (1-64,000 Hz)
- Direction of reference run (1, -1)
- Reference run offset (-8,000,000 - +8,000,000)
- Number of input for limit switch and reference switch (-1 = not defined, 0-7)
- Number of the inputs for manual control (-1= not defined, 0-7)
- Number of the inputs for start and stop (-1= not defined, 0-7)
- Software limit switch (-8,000,000 - +8,000,000 increments)
- Reverse play compensation (0 - 8,000,000)

Code-No.	Type
E 72017	MPM 5111



Accessories

MCM continuous path controller



Short description:

MCM Servo: motor control module for servo drives 1 to 3 axes

- 3 servo axes or mixed operation with 2 servo axes and one stepping-motor axis
- Path control: 2D and 3D interpolation
- Linear and circle interpolation, tangential control
- Position and speed control
- moments control
- Acceleration only once at the beginning, deceleration only once at the end
- Extremely fine movements of the motors; no bucking, no sputtering
- Continuous passage through any path section without "pause for thought"
- Constant path velocity with all shapes, also with individual calibration of the axes
- In path mode: variable grinding of ramps and contour
- Contouring error monitoring
- Electronic gear
- Analog output proportional to path velocity (application: laser performance control)
- Online operation via serial interface (V.24/RS 232) or (autonomous) offline operation from an EEPROM (subroutine technology)
- Command input, status and position request at any time (internal parallel operation)
- Comfortable PLC connection (inputs/outputs)
- Analog +/- 10V controller outputs and incremental encoder inputs
- 8 electrically isolated and 8 electrically isolated outputs (freely programmable)
- Complete commissioning software for adjusting the machine

Power control:

As combination with each standard servo drive with ± 10V reference!

Code-No.	Type
E 75020	MCM Servocontroller 2 Axes 19" plug-in rack
E 75021	MCM Servocontroller 3 Axes 19" plug-in rack
E75023	MCM Backplane

Accessories:

Code-No.	Type
E 75022	MCM-19" Rack incl. 220 Volt
E 75024	Air-conditioner for all MCM sub-racks
E75025	Stop module incl. 24 Volt replay

Short description:

MCM Step: motor control module for stepping motors 1 to 6 axes

- Independent control of all axes
- Path control: 2D- und 3D- Interpolation
- Linear/circular interpolation and tangential control
- 2D interpolation with independent third axis
- All path movements are calculated point by point
- Extremely fine movements of the motors; no bucking, no sputtering
- Programmable acceleration and braking ramps
- Continuous passage through any path section without "pause for thought"
- Acceleration only once at the beginning, deceleration only once at the end
- Online operation via serial interface (V.24/RS 232) or (autonomous) offline operation from an EEPROM (subroutine technology)
- Command input, status and position request at any time (internal parallel operation)
- Comfortable PLC connection (inputs/outputs)
- Pulse and direction outputs for all power drives
- 8 electrically isolated and 8 electrically isolated outputs (freely programmable)
- Input for incremental encoder with „electrical gear“ (e.g. for thread cutting)
- Freely programmable analog output (e.g. for rpm of spindle)

Code-No.	Type
E 72030	MCM Stepper motor controller 2 axes, 8 inputs ,8 outputs
E 72031	MCM Stepper motor controller 3 axes, 8 inputs ,8 outputs
E 72032	MCM Stepper motor contr. 3 axes, 28 inputs ,28 outputs
E 72033	MCM-Stepper motor contr. 4 axes, 28 inputs,28 outputs
E 62001	2-phase power-control 2,8 A, 70 V
E 62002	2-phase power-control 6 A, 70 V
E 62003	2-phases power-control 12 A, 70 V
E 62010	3-phase power-control 5,5 A, 120 V
E 75026	Sub-rack for MCM Step für E72030
E75027	Sub-rack for MCM Step für E72032



ECOSTEP®: Profibus DP - programmable I/O's - CANopen-networks

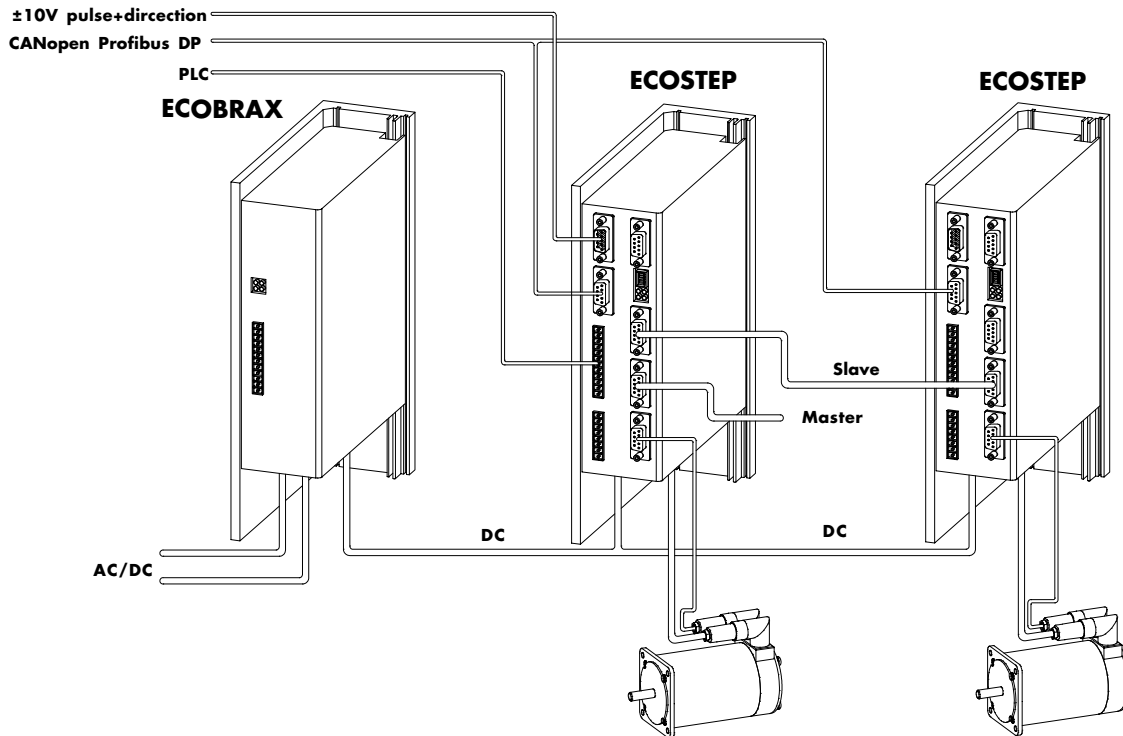

ECOSTEP® is a controller that regulates 2-phase stepping motors in closed current, velocity and position loop. The controller has the following features:

- * ECOSTEP®: 200 UL/CSA certificate
- * ECOSTEP® 100 AJ + PJ: UL/CSA certificate
- * Simultaneous command input through Profibus DP or CAN, RS485 (PPI), RS232, Step & Direction and +/-10 V (13 bit)
- * Overshot-free positioning mode due to adaptable velocity profiles
- * Programmable electronic gear
- * 8 digital inputs provide polling of 256 free connectable sequence tasks within 1 ms
- * 2 free programmable output 24 V x 0.5 A
- * Time variant control of holding brakes
- * 32 bit trouble shooting performance with high safety level
- * Interpolation via CANopen
- * Joystick operation mode via +/-10 V analogous input



Accessories

Servo - steppingmotor techniques 2 - 4

Servo stepping-motor

Size 23

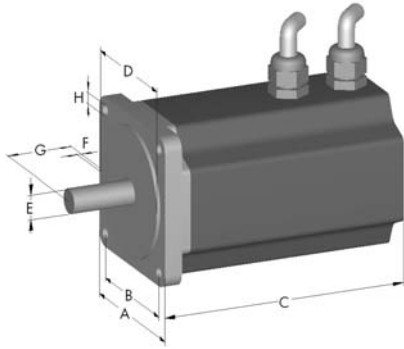

Size 34 - 42

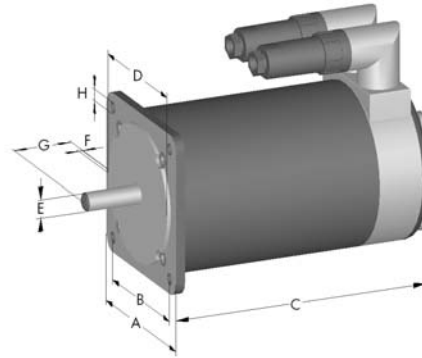

Code-No.	Size	A	B	C	D	E	F	G	H	Static torque (Nm)	Axial load	Moment of inertia	Mass (kg)	intermediate circuit-voltage	
E52	00	23 *	57	47,1	87	38,1	8,0	1,6	20,6	5,0	1,0	80	0,26 kg cm ²	0,8	60 V
E52	01	23 *	57	47,1	109	38,1	8,0	1,6	20,6	5,0	1,8	80	0,46 kg cm ²	1,4	90 V
E52	02	23 *	57	47,1	144	38,1	8,0	1,6	20,6	5,0	2,8	80	0,69 kg cm ²	1,8	150 V
E52	03	34	86	69,6	114	73,0	12,0	1,6	30,5	5,5	3,5	180	1,4 kg cm ²	2,5	170 V
E52	04	34	86	69,6	156	73,0	12,0	1,6	30,5	5,5	6	180	2,7 kg cm ²	3,9	170 V
E52	05	34	86	69,6	195	73,0	12,0	1,6	30,5	5,5	8	180	4,0 kg cm ²	5,7	170 V
E52	06	42	110	88,9	180	55,5	19,0	1,5	55,4	8,3	15	200	11,0 kg cm ²	8,8	170 V

2 without brake

* size 23 is delivered with a 2m open cable end

3 with brake

Connection cable

Code-Nr.	Baugröße	Bezeichnung
E52270	23	Motor plug RSV 1.6 6-pole *
E52271	23	Motor plug RSV 1.6 9-pole **
E52233-03/-05/-10	23	Motor cable extension 3/5/10m
E52234-03/-05/-10	23	Motor/Brake cable extension 3/5/10m
E52235-03/-05/-10	23	Encoder cable extension 3/5/10m
E52229-03/-05/-10	34 -42	Brake cable 3/5/10m
E52230-03/-05/-10	34 -42	Motor cable with plug 3/5/10m
E52231-03/-05/-10	34 -42	Encoder cable with plug 3/5/10m

* for extension of the cable end (motor size 23 without brake)

** for extension of the cable end (motor size 23 with brake)

Technical data Encoder

Selectivity	[Imp/U]	2000
Circuit voltage	U _B [V]	5 (±10%)
Current consumption	I _B [mA]	100
Signal specification	RS422	

Braking data

Size	Braking moment	Additional Motor length
23	1,5 Nm	32 mm
34 - 42	4,5 Nm	46 mm

E52 3 00

Sample ordering code:
Size 23 with brake





ECOSTEP®

A new positioning drive

- exceeds the features of AC servo motors
- considers the cost-effectiveness of stepper motors

ECOSTEP®

The features

- encoder commutated multi-pole synchronous motor
- significantly more favourable relation of torque to construction volume
- ultra-high dynamic brushless drive
- handles high load inertia even without gearbox
- torque range from 1 Nm up to 25 Nm
- motor sizes NEMA 23, 34 and 42
- optional holding brake full digital controlled drive
- positioning resolution up to 8000 PPR

• ECOSTEP 200 a compact sized control unit for flexible system integration

Basic Functions

- digital speed and positioning control providing position, velocity and torque limitation
- monitoring short circuit, voltage, encoder, tracking errors and i²t
- setting parameters by RS232/485 or CAN serial interface
- scalable analog monitors for any actual values
- intelligent control of a holding brake providing automatic voltage reduction
- evaluation of overtravel limit switches and home sensors for different indexation modes
- enabling powerstage and reset of error status by digital inputs
- indication of ready status by digital output

Positioning Control by Fieldbus

- command input by RS232/485 or CAN serial interface fieldbus
- programmable velocity profile

Positioning Control by PLC Interface

- up to 256 motion profiles including storability of position, velocity and acceleration
- selection of the profiles with digital inputs
- configurable feedback by up to 8 digital inputs

Positioning with pulse and direction

- scalable pulse and direction input meeting RS422 standard
- programmable maximum acceleration and velocity

Master/Slave Positioning

- programmable electronic gear and cam discs with master encoder input
- galvanically insulated output of the signals of the motor encoder as master for following drives

Speed Controller with analog command

- scalable speed command by
- analog +/- 10 V input, 10 bit resolution

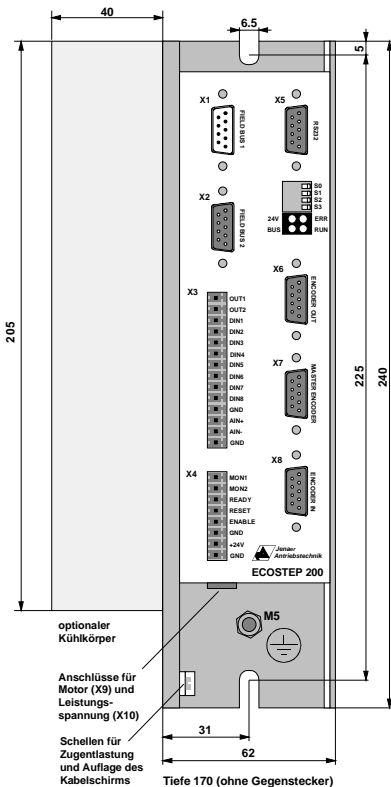

optional dissipator

Connections for motor (X9) and voltage (X10)

Clips for strain relief and support of cable screen

Depth 170 (without plug)



Code-No.	Type	Rated voltage	Current	Selectivity	Dimensions (mm)	Weight	Interface
E 52250	ECO STEP	24-150 VDC	12 A	8000 Increments/revolution	240x62x170	1,8 kg	CAN open RS 232 pulse + direction ± 10 V 8 inputs 2 outputs
E52232	Fieldbus						

Accessories

Servo - steppingmotor techniques 4 - 4



ECOBRAХ

Intelligent rectifier up to 3.1 kVA with braking chopper

- Same dimensions as ECOSTEP0
- Power supply AC 18- 110 V ' 10A/20A 1/3-phase
- Protection until 20A T(inert)
- Braking resistor power 40 W cont./ 650 W peak
- Security: selftunable braking chopper

Why not direct power supply to AC 3x400V ?

That's a question of the driving power in use.

Between 50-700W the combination DC24Vx4A or DC 150Vx8A is more effective and less power consuming for the winding as DC 300V/0,3A or DC 600V/2A.

In addition, the ECOBRAX is very flexible and can be used for all ECOSTEPs. You can keep the ECOBRAX and just use another transformer to supply the best combination of voltage x current.

Code-No.	Type
E 52251	ECOBRAХ 200 - BA
E 52252	ECOBRAХ 200 - AA - 000 for E52261

Transformers for ECOBRAX



Although it is very convenient to use DC24V power supply for the small 23 motors, it is more useful for multi-axis applications to supply the small 23 motors with DC 60V/12A instead of DC 24/30A.

Thus, as soon as 2 or more servomotors are driven by one DC bus, the combination of 1 transformer + 1 ECOBRAX + X ECOSTEPs is more effective and less expensive than cycloconverting at each drive.

Code-No.	Type	Primary winding 50/60Hz	Secondary to ECOBRAX	Rated power	Dimensions mm	Weight
E52260	SV 60/24	230 V _{AC}	60 V _{DC}	300 VA	100x80x21	5 kg
E52261	TE500-42-230	230 V _{AC}	42 V _{AC}	500 VA	228x110x257	16 kg
E52262	TE500-85-230	230 V _{AC}	85 V _{DC}	500 VA	150x180x130	10 kg
E52263	TD1000-85-400	400 V _{AC}	85 V _{AC}	1000 VA		
E52264	TD1500-85-400	400 V _{AC}	85 V _{AC}	1500 VA		

Motor	Number	ECOBRAХ	Transformator
23	1 - 2		SV60/24 (*)
23	3 - 10	200-AA-000	TE500-42-230
34	1 - 2	200-BA-000	TE500-85-230
34	3 - 4	200-BA-000	TD1000-85-400
42	1	200-BA-000	TD500-85-400
42	2 - 3	200-BA-000	TD1000-85-400
34/42	> 4	200-BA-000	TD1500-85-400

(*) In the SV 60/24 transformer the current is rectified. No ECOBRAX is required.



3.2

Accessories

Servo motor 1 - 2

Servomotor

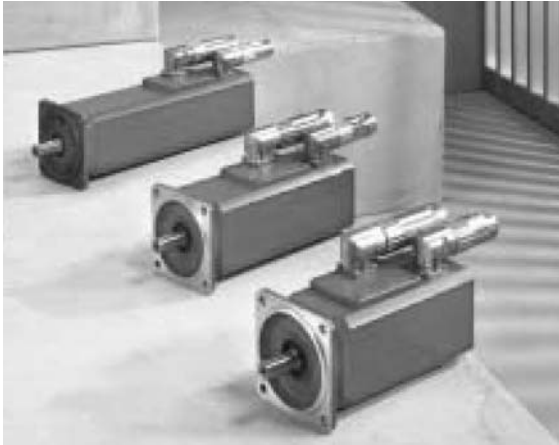

By using high-energy magnetic material NdFeB (size 4x: SmCo) it is possible to design small diameter disc motors. For this reason and due to a carefully optimized technical construction of the rotor, the motors have a low moment of inertia.

The stability of the magnetic material and the design of the magnetic field in the face of demagnetisation allow maximum currents of up to 4 times the rated current.

This results in a high acceleration capacity of the low-inertia three-phase AC servo drives.

Through the excitation of the permanent magnets, no Joule's heat losses occur in the rotor.

With three-phase AC-servomotors, Joule's heat losses occur only in the stator, which can then be directly drawn off via the housing.

These favourable cooling conditions allow high-capacity windings. Since all the Joule's heat losses are drawn off directly via the housing, the motors are designed at low cost with the enclosure type providing protection in accordance with IP 54 (optional: IP 65; size 4x: IP65 standard) and they are thus very resistant to liquids and dirt.

Synchronous servo motors with 400V system voltage, n_N 3000 [min⁻¹]

Code-No.	Motor	M_0	I_0	M_{DYN}	I_{max}	M_{OVR}	I_{OVR}	J_{mot}	J_{bmot}	M_{B1}	M_{B2}	W_{max1}	W_{max2}	
		[Nm]	[A]	[Nm]	[A]	[Nm]	[A]	[10 ⁻⁴ kgm ²]	[Nm]	[Nm]	[kJ]	[kJ]		
E55	50	DFS56M	1	1.65	3.8	6.6	—	—	0.48	0.83	2.5	—	—	—
E55	51	DFS56L	2	2.4	7.6	9.6	—	—	0.83	1.18	2.5	—	—	—
E55	52	DFS56H	4	2.8	15.2	11.2	—	—	1.53	1.88	5	—	—	—
E55	53	CFM71S	5	3.3	16.5	13.2	7.3	4.8	4.89	6.65	10	5	14	20
E55	54	CFM71M	6.5	4.3	21.5	17.2	9.4	6.2	6.27	8.03	14	7	11	18
E55	55	CFM71L	9.5	6.2	31.4	25	13.8	9	9.02	10.8	14	10	11	14
E55	56	CFM90S	11	7.3	39.6	29	16	10.6	17.4	21.2	28	14	10	20
E55	57	CFM90M	14.5	10.1	52.2	40	21	14.6	22.3	26.1	40	20	4.5	15
E55	58	CFM90L	21	14.4	75.6	58	30.5	21	32.1	35.9	40	28	4.5	10
E55	59	CFM112S	23.5	15	82.3	60	34	22	68.4	84	55	28	18	36
E55	60	CFM112M	31	20.5	108.5	82	45	30	88.2	104	90	40	7	32
E55	61	CFM112L	45	30	157.5	120	65	44	128	143	90	55	7	18
E55	62	CFM112H	68	43	238.0	172	95	60	190	209	90	55	7	18

M_0	Stand still torque	Nm	n_N	nominal revolutions (1/min)
I_0	Stand still current	A	M_{B1}	Standard brake torque
M_{DYN}	Dynamic-torque	Nm	M_{B2}	Reduced brake torque
I_{max}	Max. current	A	W_{max1}	Max. possible brake moment during a maintenance interval
M_{OVR}	Max. torque with external cooling	Nm		
I_{OVR}	Max. current with external cooling	A		
J_{mot}	Inertia of masses	10 ⁻⁴ kgm ²	W_{max2}	Max. possible brake moment during a maintenance interval
J_{bmot}	Inertia of masses with brakes	10 ⁻⁴ kgm ²		



3.2

0 0 without brake
1 1 with brake

E55 0 50

Sample order code:
Motor DFS56M, 1,00 Nm for 400 V AC, without brake



Accessories

Servo motor 2 - 2

Motor controller



MOVIDRIVE® MDX61B is the new generation of drive inverters from SEW. The new MOVIDRIVE® drive inverters of the B series convince with more basic functions, extended lower speed range, increased overload capacity and modular unit design.

As a result, AC drives with the latest digital inverter technology can now be used without restrictions in the power range from 0.55 to 132 kW . The integrated control functions and the possibility of expanding the system with technology and communication options is leading to drive systems that are designed for particularly high levels of efficiency in terms of their broad range of applications, project planning, startup and operation.

The Userpanel on the picture above is a option for the servo drive inverters, it belongs not standardly to the product!

Movidrive MDX61B Standardausführung	E55201	E55202	E55203	E55204	
Movidrive MDX61B Technologieausführung	E55301	E55302	E55303	E55304	
Size	Size 0	Size 1	Size 2		
Input					
Supply voltage	V_{mains}	3 x AC 380 V -10% ... 3 x AC 500 V +10%			
Mains frequency	f_{mains}	50 Hz ... 60Hz ±5%			
Rated supply current ¹⁾ (at $V_{mains} = 3 \times AC 400 V$)	I_{mains} 100% 125%	AC 3.6 A AC 4.5 A	AC 6.3 A AC 7.9 A	AC 11.3 A AC 14.1 A	AC 21.6 A AC 27.0 A
Output					
Apparent output power ²⁾ (at $V_{mains} = 3 \times AC 380 V ... 500V$)	P_{rated}	2.8 kVA	4.9 kVA	8.7 kVA	16.8 kVA
Rated output current (at $V_{mains} = 3 \times AC 400 V$)	I_N	AC 4 A	AC 7 A	AC 12.5 A	AC 24 A
Current limitation (Motor and regenerative)	I_{max}	200% i_{Nr} duration depending on capacity utilization		150% i_{Nr} duration depending on capacity utilization	
Internal current limitation		$I_{max} = 0...150\%$ adjustable		$I_{max} = 0...150\%$ adjustable	
Minimum permitted braking resistor value (4Q-operating)	R_{Bwmin}	68 Ohm		47 Ohm	22 Ohm
Output voltage	U_{out}	Max. U_{mains}			
PWM-frequency	f_{PWM}	Adjustable: 4/8/12/16 kHz			
Speed range / resolution	$n_a/\Delta n_c$	-6000 ... 0... +6000 min ⁻¹ / 0.2 min ⁻¹ across the entire range			
General					
Power loss at S_N ²⁾	P_{Vmax}	74 W	130 W	220 W	400 W
Cooling air consumption		9 m ³ /h		80 m ³ /h	
Mass		2.8 kg	3.5 kg	6.6 kg	
Dimensions	WxHxD	95 x 317 x 260 mm		105 x 335 x 294 mm	
Constant load Recomm. motor power	P_{Mot}	1.5 kW	3.0 kW	5.5 kW	11 kW
Variable torque load or constant load without overload Recomm. motor power	P_{Mot}	2.2 kW	4.0 kW	7.5 kW	15 kW
VFC operating mode ($f_{PWM} = 4kHz$) Continuous output current = 125% (at $U_{mains} = 3 \times AC 400 V$)	I_N I_D	AC 5 A	AC 8.8 A	AC 15.6 A	AC 30 A
CFC/Servo operating mode ($f_{PWM} = 8kHz$) Continuous output current = 100%	I_N I_D	AC 4 A	AC 7 A	AC 12.5 A	AC 24 A



3.2

Accessories

Rotary motor

Rotary synchronous motor RSMR-T-24-145x25

Code-No.	Type
E52500	RSMR-T-24-145x25-GS
E52501	RSMR-T-24-145x25-GT

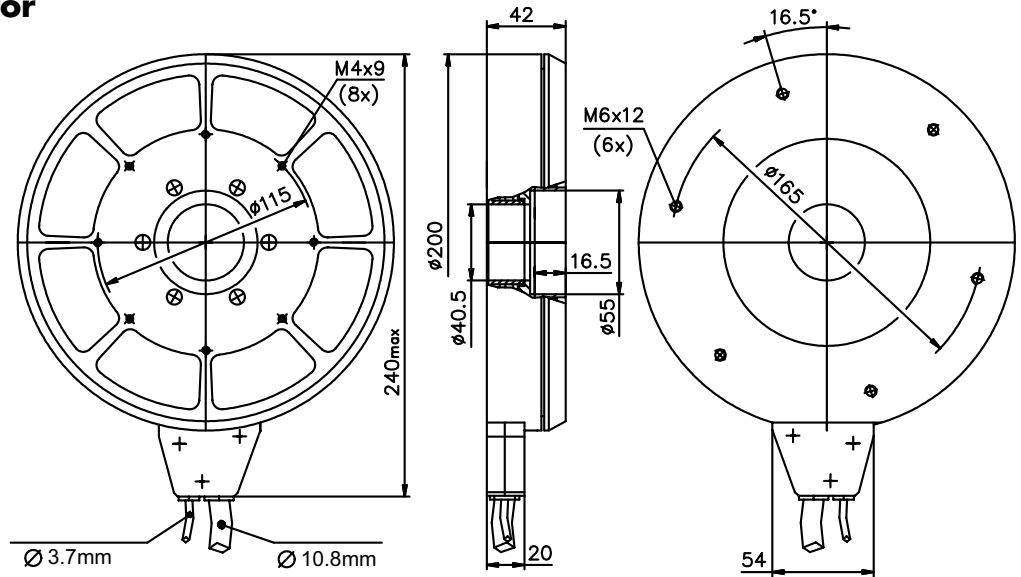

FEATURES:

- Iron-core three-phase rotary synchronous motor with rare-earth magnets for high force density.
- Direct drive (no gear, no backlash), low profile (height 42 mm) with hollow shaft (Ø40 mm).
- Built-in precision ball bearing, sine optical encoder, thermistors for overheating protection.
- High precision, repeatability and resolution, low cogging, smooth movement.
- High motor stiffness and large bandwidth by position regulator with encoder feedback.

APPLICATIONS:

Semiconductor manufacturing, pick and place machines, indexing tables.

CONSTRUCTION:

Motor consist of a fixed lamination stack with windings (stator) and rotated steel ring with glued permanent magnets (rotor). Windings are encapsulated in thermally conductive epoxy. The smoothness of movement is achieved by sinusoidal commutation of motor phases currents.

SPECIFICATION OF RSMR-T-24-145x25-

		GS	GT
Number of poles pairs 2P		17	17
Peak torque Mp (coil at 20°C)	Nm	45	45
Continuous torque Ma (coil at 120°C)	Nm	17	17
Bearing friction torque Mb	Nm	0.2	0.2
Cogging (detent) torque Mc	Nm	0,4	0,4
Peak current at Mp	Arms	14,0	24,2
Continuous current at Ma	Arms	5,1	8,7
Inductance L	mH	15.2	5.1
Resistance R	Ohm	2.9	0.96
Maximum velocity Np at 150 VDC and Mp	Rpm	214	412
Maximum velocity Na at 150 VDC and Ma	Rpm	393	701
Maximum velocity Nb at 150 VDC and Mb	Rpm	514	887
Maximum bearing velocity	Rpm	2000	2000
Rotor moment inertia	Kg·m ²	0.01	0.01
Motor weight	Kg	7	7
Maximal user payload	Kg	25	25
Axial / radial runout	micron	20	20
Number of encoder lines		2048	2048
Position accuracy	arc.sec.	30	30
Repeatability	arc.sec.	2	2
Resolution	arc.sec.	0,5	0,5



3.2

E52500

Sample order code:
RSMR-T24-145x25 GS

3.2 / 14



Accessories

Rotary motor

Rotary synchronous motor RSMR-T-24-237x25

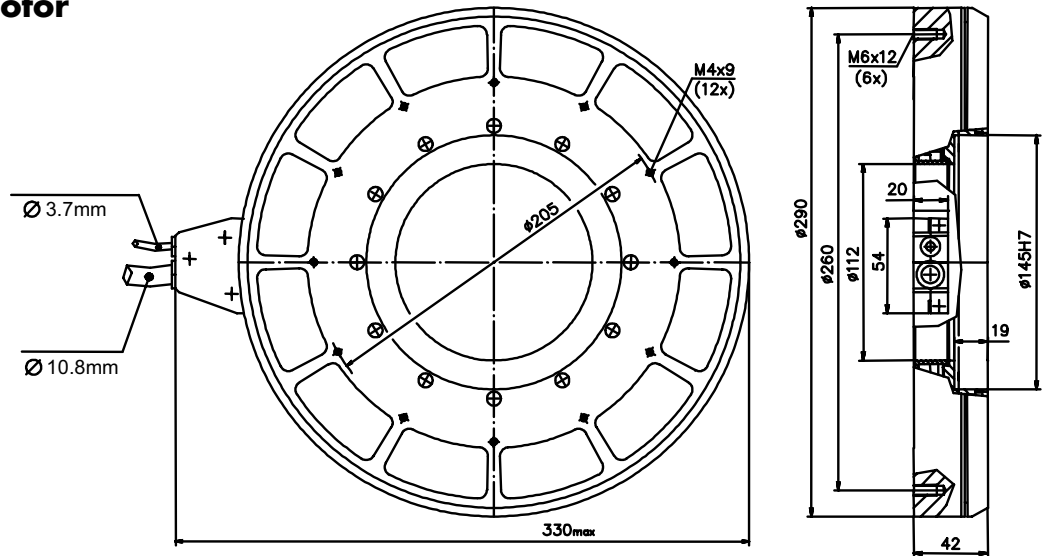

Code-No.	Type
E52502	RSMR-T-24-237x25-GS
E52503	RSMR-T-24-237x25-GT

FEATURES:

- Iron-core three-phase rotary synchronous motor with rare-earth magnets for high force density.
- Direct drive (no gear, no backlash), low profile (height 42 mm) with hollow shaft (Ø112 mm).
- Built-in precision ball bearing, sine optical encoder, thermistors for overheating protection.
- High precision, repeatability and resolution, low cogging, smooth movement.
- High motor stiffness and large bandwidth by position regulator with encoder feedback.

APPLICATIONS:

Semiconductor manufacturing, pick and place machines, indexing tables.

CONSTRUCTION:

Motor consist of a fixed lamination stack with windings (stator) and rotated steel ring with glued permanent magnets (rotor). Windings are encapsulated in thermally conductive epoxy. The smoothness of movement is achieved by sinusoidal commutation of motor phases currents.

SPECIFICATION OF RSMR-T24-237x25-

		GS	GT
Number of poles pairs 2P		31	31
Peak torque M_p (coil at 20°C)	Nm	111	111
Continuous torque M_a (coil at 120°C)	Nm	42	42
Bearing friction torque M_b	Nm	0,3	0,3
Cogging (detent) torque M_c	Nm	0,8	0,8
Peak current at M_p	Arms	14,0	24,2
Continuous current at M_a	Arms	5,1	8,7
Inductance L	mH	22,9	7,6
Resistance R	Ohm	4,3	1,4
Maximum velocity N_p at 310 VDC and M_p	Rpm	180	330
Maximum velocity N_a at 310 VDC and M_a	Rpm	325	565
Maximum velocity N_b at 310 VDC and M_b	Rpm	428	734
Maximum bearing velocity	Rpm	923	923
Rotor moment inertia	Kg·m ²	0,07	0,07
Motor weight	Kg	10	10
Maximal user payload	Kg	65	65
Axial / radial runout	Micron	20	20
Number of encoder lines		5400	5400
Position accuracy	arc.sec.	30	30
Repeatability	arc.sec.	2	2
Resolution	arc.sec.	0,2	0,2

E52502

Sample order code:
RSMR-T24-237x25 GS

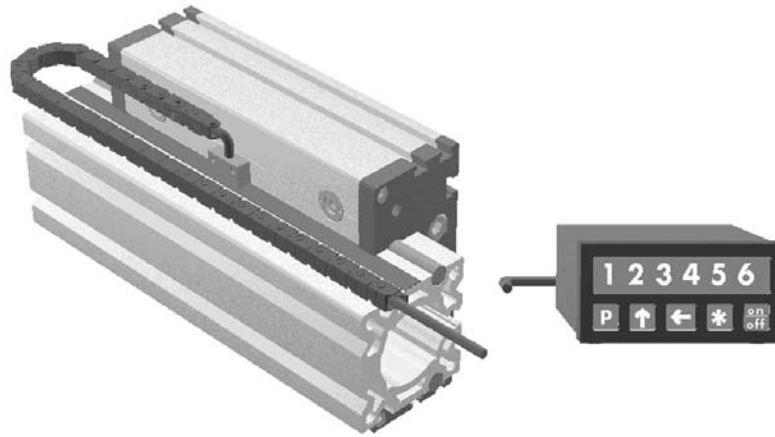

Electronic display MA 502

The incremental electronic display MA01/1 for hodometry and goniometry is one component of the magnetic-tape length measuring system and can only be operated together with a magnetic sensor and the magnetic tape.
The MA01/1 is available as 1-channel (to connect one sensor only) or as 2-channel version:

Features:

- integrated electronical evaluation
- front mounted keyboard with on/off key
- programmable parameters to adjust the MA01/1 to the specific setting of the machine
- "incremental measurement" function
- programmable last value memory
- direct input of reference / offset value
- option: external battery module power supply; automatic control of state of charge (see Accessories/Options)
- well readable LED display
- reference input

Magnetic sensor MS500

Compact magnetic sensor with integrated electronical evaluation and direct rectangular pulse output.
Operation in connection with the magnetic SIKO tape (type MB).

Features:

- integrated electronical evaluation
- maximum resolution 0.05 mm (with quadruplex evaluation)
- accuracy of the magnetic system 0.1 mm
- online connection to other electronic counters (e.g. PLC or SIKO-MA ...)
- low-priced linear measurement
- simple mounting
- output in real time
- simple hodometry and goniometry
- pulse output is compatible to conventional incremental encoders
- suitable for high velocities

	Electronic display MA01/1	Magnetic sensor MSK
Power supply	24 V DC ± 20%; 230 V AC; 115 V AC	Mini-DIN 7-polig
Display range	12-stellige LCD Dotmatrix	-
Output signal	-	-
Output circuit	-	PP (Push-Pull) TTL (RS422)
Velocity	max. 5 m/s	< 10 m/s
Distance sensor/tape	-	0,1 -2,0 mm
System of protection	for complete system: IP 40 flush-type: IP 60	IP 67
Resolution	0,01 / 0,1 / 1 / 10 mm	0,05 mm optional: 0,25 mm (quadruplex evaluation) 0,025 mm
Repeating accuracy	± 1 Digit	-
Accuracy	± (0,05+0,01 × L)mm [L in m]	see following electronic
Code-No.	E 77070	E 77076

Magnetic tape

The magnetic tape consists of a strip polarised at defined intervals, which is firmly connected with a carrier tape. In addition, a magnetically conducting cover strip made of stainless steel is included in the scope of delivery.

- Simple mounting by a double-sided Scotch tape
- High resistance against external influences

Code-No.
E 77077....

