



## **CAM CLUTCHES MZEU-K SERIES**



**TSUBAKI EMERSON**

**- the evolution of Cam Clutches -**

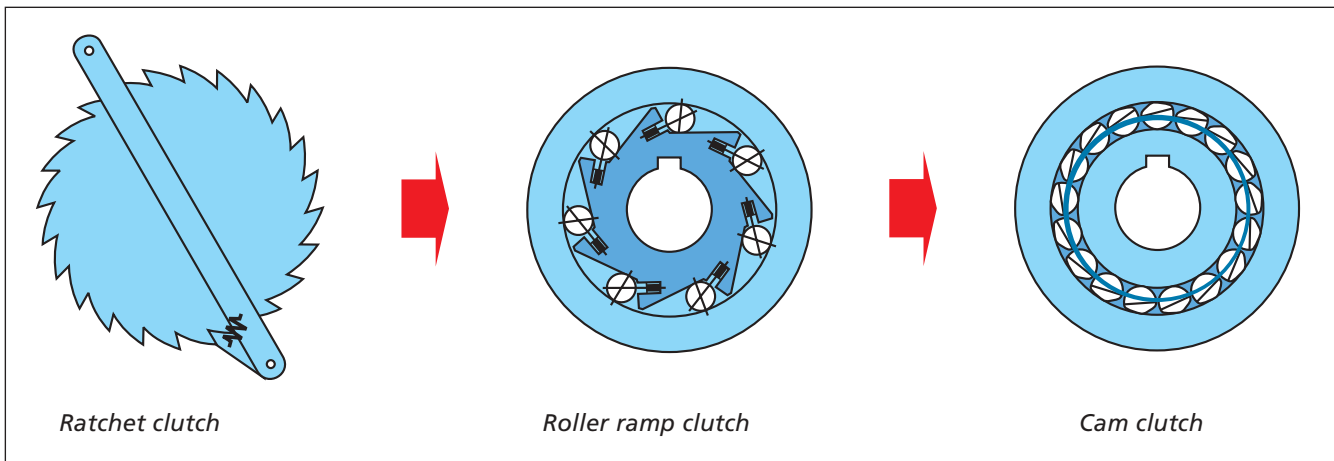

2

Tsubaki MZEU-K Cam Clutches are sprag type one-way clutches and leader in its class. The one-way clutch was originally developed as a ratchet clutch later to become a roller ramp clutch and finally became Tsubaki's Cam Clutch. The Tsubaki Cam Clutch ensures a longer life to the mechanism than any other type of one-way clutch. Tsubaki has a vast amount of

experience producing this style of clutches and supplies them to many kinds of industry throughout the world.

MZEU- K series Cam Clutches are the most recent development of one-way clutches, based on historically proven European style clutches.

**- introduction of our MZEU-K programm**

MZEU-K series Cam Clutches are modular type one way clutches, supplied as a basic type clutch with

standardized optional parts E1, E2, E5 & E7 flanges, E3 torque arm and E4 cover.



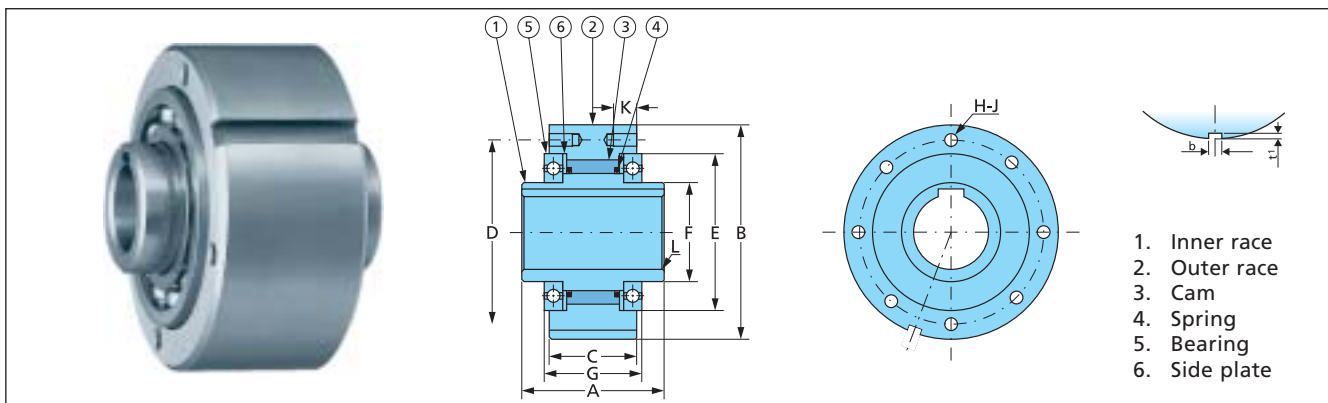

Basic type MZEU-K Cam Clutch. Summary of parts and dimensions (referring to table below).

**- dimensions and capacities -**

Model	Torque capacity	Max. overrunning speed		Drag torque	Bore size	Keyway	A	B	C	D	E	F	G	H-J	K	L	b	t <sub>1</sub>	Weight
	N-m	Inner race	Outer race																
MZEU12K	60	2,000	1,000	0.20	12	4×1.8	42	62	20	51	42	20	27	3-Ø5.5	-	0.8	4	2.5	0.5
MZEU15K	100	1,800	900	0.20	15	5×2.3	52	68	28	56	47	25	32	3-M5	8	0.8	5	3.0	0.8
MZEU20K	245	1,600	700	0.29	20	6×2.8	57	75	34	64	55	30	39	4-M5	8	0.8	6	3.5	1.2
MZEU25K	425	1,600	600	0.33	25	8×3.3	60	90	35	78	68	40	40	4-M6	10	0.8	8	4.0	1.8
MZEU30K	735	1,500	500	0.39	30	8×3.3	68	100	43	87	75	45	48	6-M6	10	1.0	8	4.0	2.6
MZEU35K	1,015	1,400	300	0.49	35	10×3.3	74	110	45	96	80	50	51	6-M6	12	1.0	10	5.0	3.2
MZEU40K	1,350	1,400	300	0.59	40	12×3.3	86	125	53	108	90	55	59	6-M8	14	1.3	12	5.0	4.8
MZEU45K	1,620	1,400	300	0.69	45	14×3.8	86	130	53	112	95	60	59	8-M8	14	1.3	14	5.5	6.2
MZEU50K	2,070	1,300	250	0.79	50	14×3.8	94	150	64	132	110	70	72	8-M8	14	1.3	14	5.5	8.2
MZEU55K	2,400	1,300	250	0.88	55	16×4.3	104	160	66	138	115	75	72	8-M10	16	1.5	16	6.0	9.5
MZEU60K	2,950	1,200	250	0.98	60	18×4.4	114	170	78	150	125	80	89	10-M10	16	1.5	18	7.0	12.3
MZEU70K	4,210	1,100	250	1.27	70	20×4.9	134	190	95	165	140	90	108	10-M10	16	1.8	20	7.5	18.1
MZEU80K	5,170	800	200	1.38	80	22×5.4	144	210	100	185	160	105	108	10-M10	16	1.8	22	9.0	23.1
MZEU 90	12,000	450	150	4.70	90	25×5.4	158	230	115	206	180	120	125	10-M12	20	2.0	25	9.0	28.1
MZEU100	17,600	400	130	5.39	100	28×6.4	182	270	120	240	210	140	131	10-M16	24	2.0	28	10.0	46.3
MZEU130	24,500	320	110	6.76	130	32×7.4	212	310	152	278	240	160	168	12-M16	24	2.5	32	11.0	70.2
MZEU150	33,800	240	80	8.13	150	36×8.4	246	400	180	360	310	200	194	12-M20	32	2.5	36	12.0	146.3

Note: For the dimensions: bore size, B and b we recommend the tolerances H7, h7 and P10 as stated in the table above.

**- installation and usage -**

- The sizes MZEU12-K up to MZEU 80-K are supplied pre-greased ex works and do not need any further lubrication except some light maintenance as shown on page 10, to ensure an appropriate function of the lateral roller bearings.
- The ambient temperature range is -40°C up to +40°C. For higher range temperatures please consult Tsubaki.
- The sizes MZEU90-K up to MZEU 150-K require oil lubrication. Refer to lubrication and maintenance on page 10.
- We recommend a shaft tolerance of h7 with a standard key. Our keyways are standardized according to DIN 6885.1
- We recommend applying tolerance H7 or H8 to re-work sprockets, pulley, gears or other parts to be fitted. Before installation of the clutch, it's recommended to clean both ends of the outer race and contact surface of the flange(s), torque arm, cover or fitted part.
- For the sizes MZEU90-K up to MZEU150-K, apply

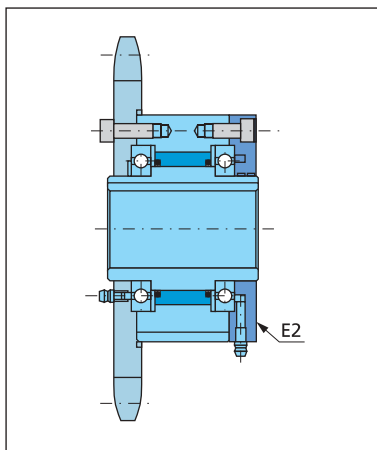

Installation example 1.

- seal adhesive (supplied with each optional part) to prevent oil leakage.
- Before assembly of the optional or fitted part(s) check the rotation direction of the clutch, indicated by an arrow on the inner race side surface. When installing sprocket, gear, pulley or other items to the clutch, always use bolts to assemble them.
- Size and quantity are mentioned under H-J in the above mentioned table.
- By installing any type of optional or fitted part in the opposite way the clutch's direction of rotation can be changed.
- Fix a grease nipple to each optional or fitted part.
- When mounting the clutch onto the shaft, apply pressure to the inner race, but **never** to the outer race.
- For high speed indexing applications (over 50 c/min) strong springs are recommendable and can be supplied accordingly.
- Refer to page 10 for other usage indicators and further advise.

**- Cam Clutches series MZEU-K with E1 and E2 flange -**

4

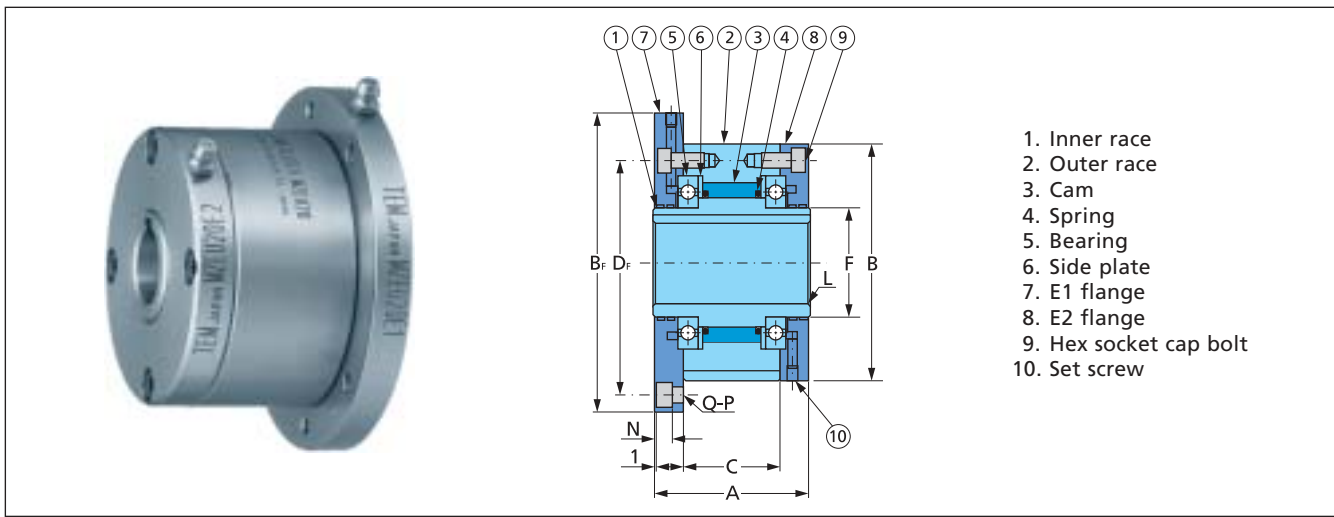

- 1. Inner race
- 2. Outer race
- 3. Cam
- 4. Spring
- 5. Bearing
- 6. Side plate
- 7. E1 flange
- 8. E2 flange
- 9. Hex socket cap bolt
- 10. Set screw

Basic type MZEU-K Cam Clutch provided with E1 and E2 flanges. Summary of parts and dimensions (referring to table below).

**- dimensions and capacities -**

Model	Torque capacity N-m	Max. overrunning speed		Drag torque N-m	Bore size H7	Keyway	A	B	B <sub>f</sub>	C	D <sub>f</sub>	F	L	M	N	O-P	Weight kg
		Inner race r/min	Outer race r/min														
MZEU12K E1+E2	60	2,000	1,000	0.20	12	4×1.8	42	62	85	20	72	20	0.8	10.0	5.7	3-Ø5.5	1.1
MZEU15K E1+E2	100	1,800	900	0.20	15	5×2.3	52	68	92	28	78	25	0.8	11.0	5.7	3-Ø5.5	1.5
MZEU20K E1+E2	245	1,600	700	0.29	20	6×2.8	57	75	98	34	85	30	0.8	10.5	5.7	4-Ø5.5	1.9
MZEU25K E1+E2	425	1,600	600	0.33	25	8×3.3	60	90	118	35	104	40	0.8	11.5	6.8	4-Ø6.6	2.9
MZEU30K E1+E2	735	1,500	500	0.39	30	8×3.3	68	100	128	43	114	45	1.0	11.5	6.8	6-Ø6.6	4.0
MZEU35K E1+E2	1,015	1,400	300	0.49	35	10×3.3	74	110	140	45	124	50	1.0	13.5	6.8	6-Ø6.6	5.2
MZEU40K E1+E2	1,350	1,400	300	0.59	40	12×3.3	86	125	160	53	142	55	1.3	15.5	9.0	6-Ø9.0	7.9
MZEU45K E1+E2	1,620	1,400	300	0.69	45	14×3.8	86	130	165	53	146	60	1.3	15.5	9.0	8-Ø9.0	9.3
MZEU50K E1+E2	2,070	1,300	250	0.79	50	14×3.8	94	150	185	64	166	70	1.3	14.0	9.0	8-Ø9.0	11.7
MZEU55K E1+E2	2,400	1,300	250	0.88	55	16×4.3	104	160	204	66	182	75	1.5	18.0	11.0	8-Ø11	15.3
MZEU60K E1+E2	2,950	1,200	250	0.98	60	18×4.4	114	170	214	78	192	80	1.5	17.0	11.0	10-Ø11	17.7
MZEU70K E1+E2	4,210	1,100	250	1.27	70	20×4.9	134	190	234	95	212	90	1.8	18.5	11.0	10-Ø11	25.5
MZEU80K E1+E2	5,170	800	200	1.38	80	22×5.4	144	210	254	100	232	105	1.8	21.0	11.0	10-Ø11	33.2
MZEU90 E1+E2	12,000	450	150	4.70	90	25×5.4	158	230	278	115	254	120	2.0	20.5	13.0	10-Ø14	38.3
MZEU100 E1+E2	17,600	400	130	5.39	100	28×6.4	182	270	335	120	305	140	2.0	30.0	17.5	10-Ø18	68.8
MZEU130 E1+E2	24,500	320	110	6.76	130	32×7.4	212	310	380	152	345	160	2.5	29.0	17.5	12-Ø18	98.2
MZEU150 E1+E2	33,800	240	80	8.13	150	36×8.4	246	400	485	180	445	200	2.5	32.0	21.5	12-Ø22	198.2

Note: For the dimensions: bore size, B and b we recommend the tolerances H7, h7 and P10 as stated in the table above.

**- installation and usage -**

1. The Cam Clutch is delivered as a combination of a basic type clutch, an E1-flange and an E2 flange, each one packed and supplied as an individual part set. Each flange set comes with a complete flange kit, containing a number of bolts, a grease nipple, a locker set screw and a seal plug.
2. Check the direction of rotation before assembling, then mount both flanges making use of the flange kits.
3. Before mounting the sizes MZEU90 - MZEU150 apply the sealing adhesive, which comes along with the part sets, between body (outer race surface) and the

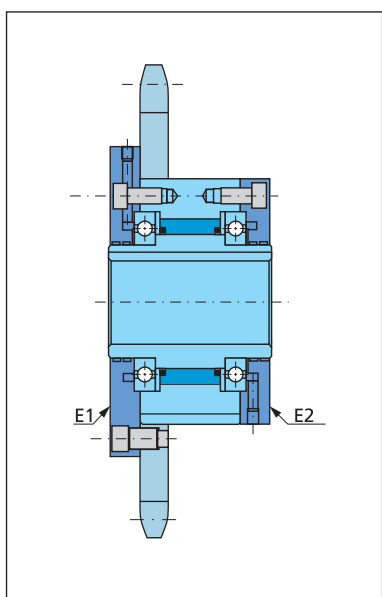

Installation example 2.

- optional part, to prevent leakage of oil during operation.
4. When installing sprocket, gear, pulley or other items to the clutch, always use bolts to assemble them. Size and quantity are mentioned under H-J, page 2. Lengths and shape are determined by the thickness of the fitted part.
5. When installing any type of optional or fitted part in the opposite way the direction of the clutch's rotation can be changed.
6. For high speed indexing applications (over 50 c/min) strong springs are recommended and can be supplied accordingly.
7. Refer to page 10 for other usage indicators and further advise.

**- Cam Clutches series MZEU-K with E2 flange and E3 torque arm**

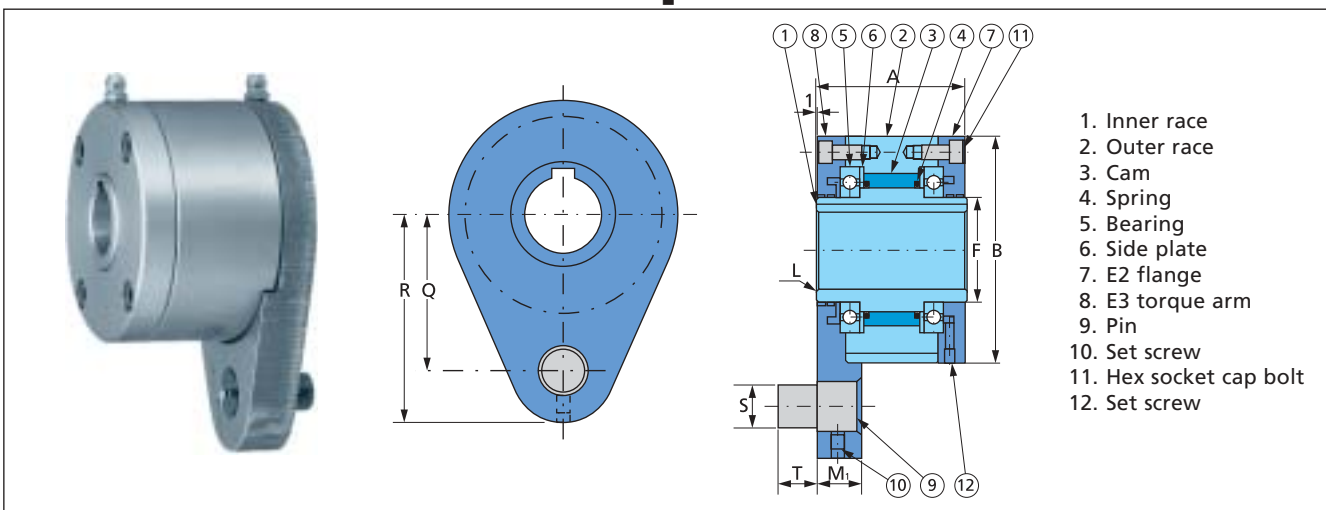

Basic type MZEU-K Cam Clutch provided with E2 flange and E3 torque arm. Summary of parts and dimensions (referring to table below).

**- dimensions and capacities -**

Model	Torque capacity	Max. overrunning speed		Drag torque	Bore size	Keyway	A	B	F	L	M <sub>1</sub>	Q	R	S	T	Weight
		Inner race	Outer race													
		N-m	r/min													
MZEU12K E2+E3	60	2,000	1,000	0.20	12	4×1.8	42	62	20	0.8	13.5	44	59	10	10	1.0
MZEU15K E2+E3	100	1,800	900	0.20	15	5×2.3	52	68	25	0.8	13.5	47	62	10	10	1.4
MZEU20K E2+E3	245	1,600	700	0.29	20	6×2.8	57	75	30	0.8	15.0	54	72	12	11	1.8
MZEU25K E2+E3	425	1,600	600	0.33	25	8×3.3	60	90	40	0.8	19.0	62	84	16	14	2.7
MZEU30K E2+E3	735	1,500	500	0.39	30	8×3.3	68	100	45	1.0	19.0	68	92	16	14	4.1
MZEU35K E2+E3	1,015	1,400	300	0.49	35	10×3.3	74	110	50	1.0	22.0	76	102	20	18	5.1
MZEU40K E2+E3	1,350	1,400	300	0.59	40	12×3.3	86	125	55	1.3	22.0	85	112	20	18	7.4
MZEU45K E2+E3	1,620	1,400	300	0.69	45	14×3.8	86	130	60	1.3	25.0	90	120	25	22	9.1
MZEU50K E2+E3	2,070	1,300	250	0.79	50	14×3.8	94	150	70	1.3	25.0	102	135	25	22	11.6
MZEU55K E2+E3	2,400	1,300	250	0.88	55	16×4.3	104	160	75	1.5	30.0	108	142	32	25	14.6
MZEU60K E2+E3	2,950	1,200	250	0.98	60	18×4.4	114	170	80	1.5	30.0	112	145	32	25	17.0
MZEU70K E2+E3	4,210	1,100	250	1.27	70	20×4.9	134	190	90	1.8	35.0	135	175	38	30	25.4
MZEU80K E2+E3	5,170	800	200	1.38	80	22×5.4	144	210	105	1.8	35.0	145	185	38	30	32.6
MZEU90 E2+E3	12,000	450	150	4.70	90	25×5.4	158	230	120	2.0	45.0	155	205	50	40	38.9
MZEU100 E2+E3	17,600	400	130	5.39	100	28×6.4	182	270	140	2.0	45.0	180	230	50	40	65.2
MZEU130 E2+E3	24,500	320	110	6.76	130	32×7.4	212	310	160	2.5	60.0	205	268	68	55	97.3
MZEU150 E2+E3	33,800	240	80	8.13	150	36×8.4	246	400	200	2.5	60.0	255	325	68	55	191.4

Note: For the dimensions: bore size and B we recommend the tolerances H7 and h7 as stated in the table above.

**- installation and usage -**

1. The Cam Clutch is delivered as a combination of a basic type clutch, an E3 torque arm and an E2 flange, each one packed and supplied as an individual part set. The flange set comes with a complete mounting kit, containing a number of bolts, a grease nipple, a locker set screw and a seal plug. The torque arm comes with an extra pin and set screw. See drawing and table above no. 9 & 10.
2. Check the direction of rotation before assembling, then mount both optional parts making use of the flange kits.

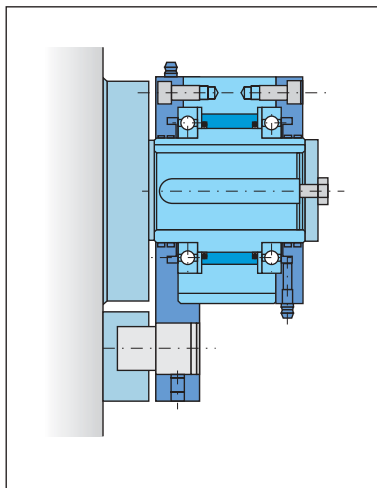

Installation example 3.

3. Before mounting the sizes MZEU90- MZEU150 apply the sealing adhesive, included with the part sets, between body (outer race surface) and the optional part, to prevent leakage of oil during operation.
4. When installing the optional parts in the opposite way the direction of the clutch's rotation can be changed.
5. Refer to page 10 for other usage indicators and further advise.

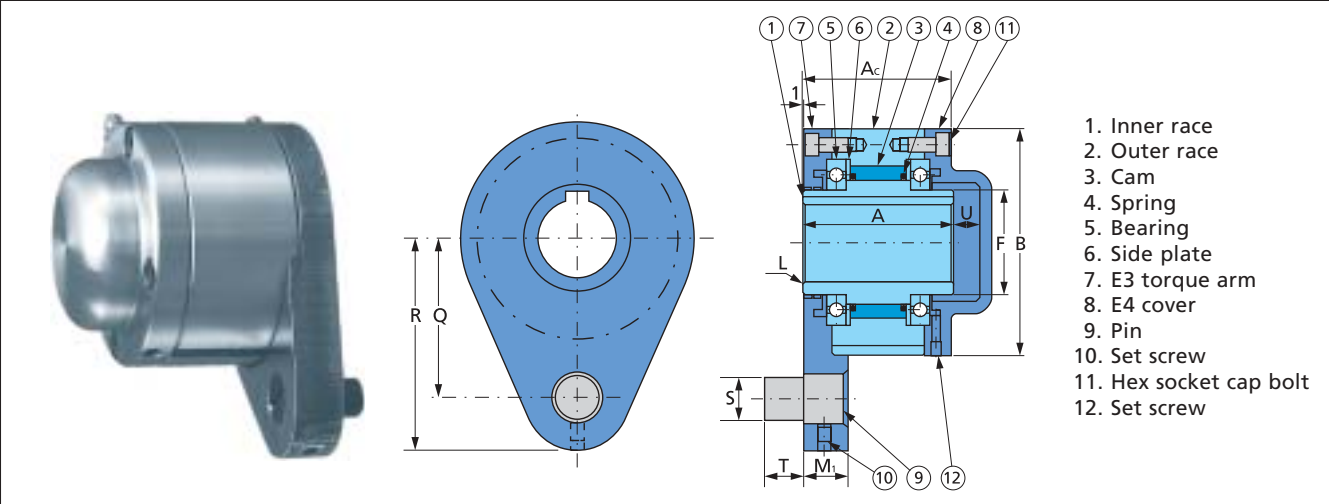

Basic type MZEU-K Cam Clutch provided with E3 torque arm and E4 cover. Summary of parts and dimensions (referring to table below).

**- dimensions and capacities -**

Model	Torque capacity N-m	Max. overrun speed		Drag torque N-m	Bore size H7	Keyway	A	A <sub>c</sub>	B	F	L	M <sub>1</sub>	Q	R	S	T	U	Weight kg
		Inner race	Outer race															
		r/min	r/min															
MZEU12K E3+E4	60	2,000	1,000	0.20	12	4×1.8	42	53	62	20	0.8	13.5	44	59	10	10	6.0	1.0
MZEU15K E3+E4	100	1,800	900	0.20	15	5×2.3	52	68	68	25	0.8	13.5	47	62	10	10	10.0	1.5
MZEU20K E3+E4	245	1,600	700	0.29	20	6×2.8	57	73	75	30	0.8	15.0	54	72	12	11	10.0	2.0
MZEU25K E3+E4	425	1,600	600	0.33	25	8×3.3	60	76	90	40	0.8	19.0	62	84	16	14	10.0	2.9
MZEU30K E3+E4	735	1,500	500	0.39	30	8×3.3	68	84	100	45	1.0	19.0	68	92	16	14	10.0	4.3
MZEU35K E3+E4	1,015	1,400	300	0.49	35	10×3.3	74	92	110	50	1.0	22.0	76	102	20	18	12.0	5.3
MZEU40K E3+E4	1,350	1,400	300	0.59	40	12×3.3	86	105	125	55	1.3	22.0	85	112	20	18	12.0	7.8
MZEU45K E3+E4	1,620	1,400	300	0.69	45	14×3.8	86	108	130	60	1.3	25.0	90	120	25	22	15.0	9.6
MZEU50K E3+E4	2,070	1,300	250	0.79	50	14×3.8	94	113	150	70	1.3	25.0	102	135	25	22	12.0	12.1
MZEU55K E3+E4	2,400	1,300	250	0.88	55	16×4.3	104	126	160	75	1.5	30.0	108	142	32	25	15.0	15.2
MZEU60K E3+E4	2,950	1,200	250	0.98	60	18×4.4	114	137	170	80	1.5	30.0	112	145	32	25	15.0	17.7
MZEU70K E3+E4	4,210	1,100	250	1.27	70	20×4.9	134	164.5	190	90	1.8	35.0	135	175	38	30	22.5	26.5
MZEU80K E3+E4	5,170	800	200	1.38	80	22×5.4	144	168	210	105	1.8	35.0	145	185	38	30	16.0	33.6
MZEU90 E3+E4	12,000	550	150	3.76	90	25×5.4	158	192	230	120	2.0	45.0	155	205	50	40	27.0	39.0
MZEU100 E3+E4	17,600	500	130	4.31	100	28×6.4	182	217	270	140	2.0	45.0	180	230	50	40	28.0	67.4
MZEU130 E3+E4	24,500	400	110	5.39	130	32×7.4	212	250	310	160	2.5	60.0	205	268	68	55	30.0	100.2
MZEU150E3+E4	33,800	300	80	6.47	150	36×8.4	246	286	400	200	2.5	60.0	255	325	68	55	32.0	194.8

Note: For the dimensions: bore size and B we recommend the tolerances H7 and h7 as stated in the table above.

**- installation and usage -**

1. This version of the MZEU-K Cam Clutch comes as a combination of a basic type clutch, an E3 torque arm and an E4 cover, each one packed and supplied as an individual part set.  
Each part set is delivered with a flange kit consisting of bolts, grease nipple, locker set screw and seal plug. The E3 kit comes with an extra pin and set screw. See drawing and table above no. 9 & 10.
2. Check the direction of rotation before assembling, then mount both flanges making use of the flange kit.
3. Before mounting the sizes MZEU90 - MZEU150 apply the sealing adhesive, included with the part sets, between body (outer race surface) and the

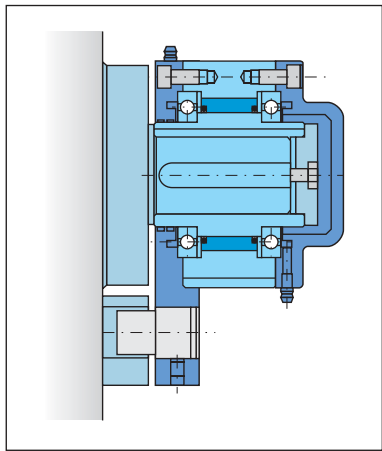

Installation example 4.

- optional part, to prevent leakage of oil during operation.
4. For the sizes MZEU12-K up to MZEU80-K assemble the shaft end plate onto the shaft before closing with the E4 cover. Refer to installation example 4.
5. Before mounting the E4 cover on Model MZEU90 up to MZEU150, packing should be fitted between the end surface of the inner race and the surface of the end plate, using sealing, washer and bolt(s). Refer to installation example 4.
6. When installing the optional parts in the opposite way the direction of the clutch's rotation can be changed.
7. Refer to page 10 for other usage indicators and further advise.

**- Cam Clutches series MZEU-K with E5 flanges on both sides -**

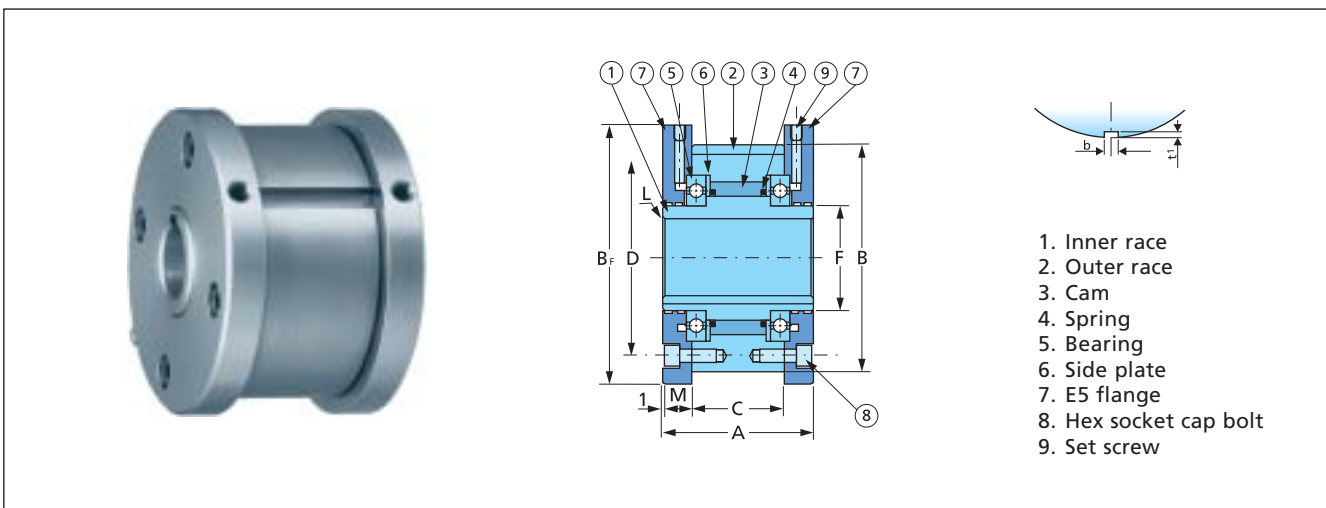

Basic type MZEU-K Cam Clutch provided with E5 flanges on both sides. Summary of parts and dimensions (referring to table below).

**- dimensions and capacities -**

Model	Torque capacity N-m	Max. overrunning speed		Drag torque N-m	Bore size H7	Keyway	A	B	B <sub>f</sub>	C	D	F	L	M	b	t <sub>1</sub>	Weight kg
		Inner race	Outer race														
		r/min	r/min														
MZEU12K E5+E5	60	2,000	1,000	0.20	12	4×1.8	42	62	70	20	51	20	0,8	10,0	4	2.5	0.5
MZEU15K E5+E5	100	1,800	900	0.20	15	5×2.3	52	68	76	28	56	25	0,8	11,0	5	3.0	0.8
MZEU20K E5+E5	245	1,600	700	0.29	20	6×2.8	57	75	84	34	64	30	0,8	10,5	6	3.5	1.2
MZEU25K E5+E5	425	1,600	600	0.33	25	8×3.3	60	90	99	35	78	40	0,8	11,5	8	4.0	1.8
MZEU30K E5+E5	735	1,500	500	0.39	30	8×3.3	68	100	109	43	87	45	1,0	11,5	8	4.0	2.6
MZEU35K E5+E5	1,015	1,400	300	0.49	35	10×3.3	74	110	119	45	96	50	1,0	13,5	10	5.0	3.2
MZEU40K E5+E5	1,350	1,400	300	0.59	40	12×3.3	86	125	135	53	108	55	1,3	15,5	12	5.0	4.8
MZEU45K E5+E5	1,620	1,400	300	0.69	45	14×3.8	86	130	140	53	112	60	1,3	15,5	14	5.5	6.2
MZEU50K E5+E5	2,070	1,300	250	0.79	50	14×3.8	94	150	160	64	132	70	1,3	14,0	14	5.5	8.2
MZEU55K E5+E5	2,400	1,300	250	0.88	55	16×4.3	104	160	170	66	138	75	1,5	18,0	16	6.0	9.5
MZEU60K E5+E5	2,950	1,200	250	0.98	60	18×4.4	114	170	182	78	150	80	1,5	17,0	18	7.0	12.3
MZEU70K E5+E5	4,210	1,100	250	1.27	70	20×4.9	134	190	202	95	165	90	1,8	18,5	20	7.5	18.1
MZEU80K E5+E5	5,170	800	200	1.38	80	22×5.4	144	210	222	100	185	105	1,8	21,0	22	9.0	23.1
MZEU90K E5+E5	12,000	450	150	4.70	90	25×5.4	158	230	242	115	206	120	2,0	20,5	25	9.0	28.1
MZEU100K E5+E5	17,600	400	130	5.39	100	28×6.4	182	270	282	120	240	140	2,0	30,0	28	10.0	46.3
MZEU130K E5+E5	24,500	320	110	6.76	130	32×7.4	212	310	322	152	278	160	2,5	29,0	32	11.0	70.2
MZEU150K E5+E5	33,800	240	80	8.13	150	36×8.4	246	400	412	180	360	200	2,5	32,0	36	12.0	146.3

Note: For the dimensions: bore size, B and b we recommend the tolerances H7, h7 and P10 as stated in the table above.

**- installation and usage -**

1. This version of the MZEU-K Cam Clutch comes as a combination of a basic type clutch, and two E5 flanges, each one packed and supplied as an individual part set. Each part set comes with a complete flange kit, containing a number of bolts, a grease nipple, a locker set screw and a seal plug.
2. Check the direction of rotation before assembling, then mount both flanges making use of the flange kit.
3. Before mounting the sizes MZEU90- MZEU150 apply the sealing adhesive, which comes along with the part sets, between body (outer race surface) and the

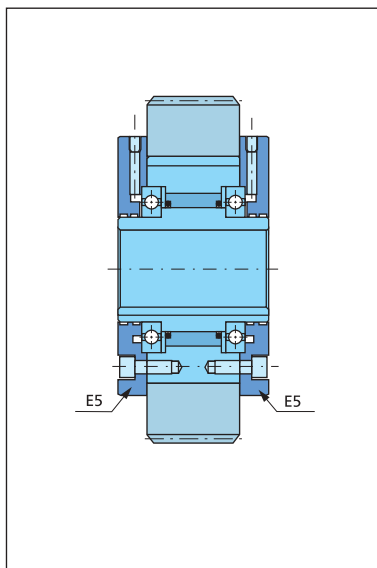

Installation example 5.

- optional part, to prevent leakage of oil during operation.
4. Insert the Cam Clutch into the appropriate unit (gear, sprocket, pulley etc.). We recommend a tolerance of H7 for the bore size. Fix the key and close the unit with the second E5 flange, making use of the flange kit.
5. MZEU-K clutches with E5 and E5 flanges can be used in both rotation directions.
6. For high speed indexing applications (over 50 c/min) strong springs are recommended and can be supplied accordingly.
7. Refer to page 10 for other usage indicators and further advise.

**- Cam Clutches series MZEU-K with E7 and E2 flange -**

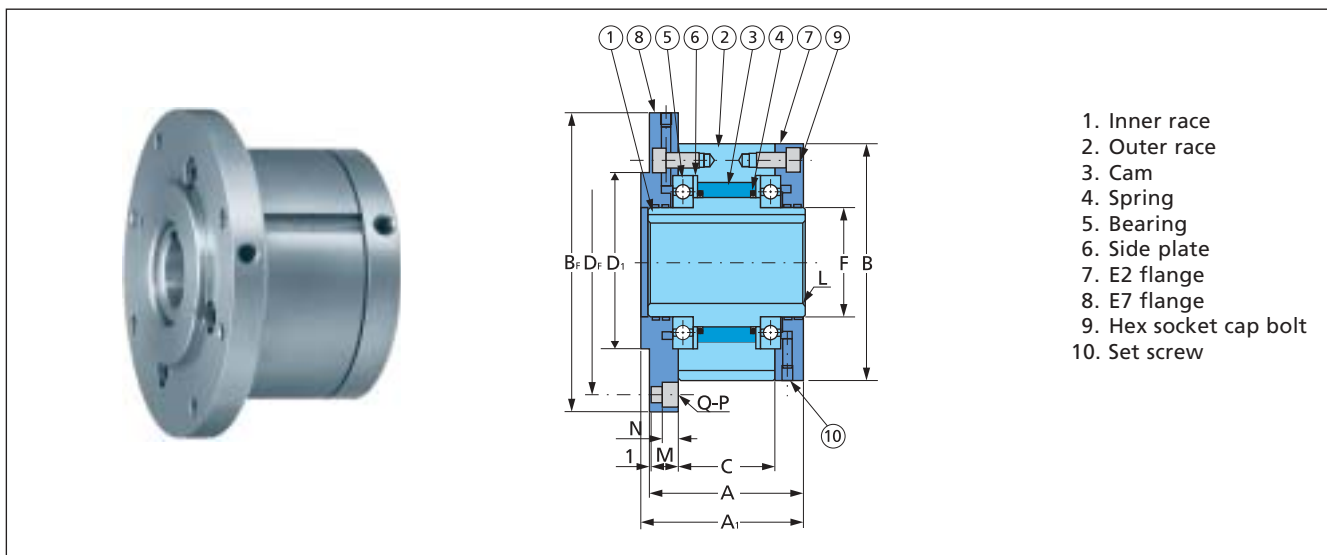

- 1. Inner race
- 2. Outer race
- 3. Cam
- 4. Spring
- 5. Bearing
- 6. Side plate
- 7. E2 flange
- 8. E7 flange
- 9. Hex socket cap bolt
- 10. Set screw

Basic type MZEU-K Cam Clutch provided with an E7 and an E2 flange. Summary of parts and dimensions (referring to table below).

**- dimensions and capacities -**

Model	Torque capacity N-m	Max. overrunning speed		Drag torque N-m	Bore size H7	Keyway	A	A <sub>1</sub>	B	B <sub>f</sub>	C	D <sub>1</sub>		D <sub>f</sub>	F	L	M	N	Q-P	Weight kg
		Inner race r/min	Outer race r/min									h7	h7							
MZEU12K E2+E7	60	2,000	1,000	0.20	12	4x1.8	42	44	62	85	20	42	72	20	0.8	10,0	5.7	3-Ø5.5	0,5	
MZEU15K E2+E7	100	1,800	900	0.20	15	5x2.3	52	54	68	92	28	47	78	25	0.8	11,0	5.7	3-Ø5.5	0,8	
MZEU20K E2+E7	245	1,600	700	0.29	20	6x2.8	57	59	75	98	34	55	85	30	0.8	10,5	5.7	4-Ø5.5	1,2	
MZEU25K E2+E7	425	1,600	600	0.33	25	8x3.3	60	62	90	118	35	68	104	40	0.8	11,5	6.8	4-Ø6.6	1,8	
MZEU30K E2+E7	735	1,500	500	0.39	30	8x3.3	68	70	100	128	43	75	114	45	1.0	11,5	6.8	6-Ø6.6	2,6	
MZEU35K E2+E7	1,015	1,400	300	0.49	35	10x3.3	74	76	110	140	45	80	124	50	1.0	13,0	6.8	6-Ø6.6	3,2	
MZEU40K E2+E7	1,350	1,400	300	0.59	40	12x3.3	86	88	125	160	53	90	142	55	1.3	15,0	9.0	6-Ø9.0	4,8	
MZEU45K E2+E7	1,620	1,400	300	0.69	45	14x3.8	86	88	130	165	53	95	146	60	1.3	15,0	9.0	8-Ø9.0	6,2	
MZEU50K E2+E7	2,070	1,300	250	0.79	50	14x3.8	94	96	150	185	64	110	166	70	1.3	13,0	9.0	8-Ø9.0	8,2	
MZEU55K E2+E7	2,400	1,300	250	0.88	55	16x4.3	104	106	160	204	66	115	182	75	1.5	17,0	11.0	8-Ø11	9,5	
MZEU60K E2+E7	2,950	1,200	250	0.98	60	18x4.4	114	116	170	214	78	125	192	80	1.5	16,0	11.0	10-Ø11	12,3	
MZEU70K E2+E7	4,210	1,100	250	1.27	70	20x4.9	134	136	190	234	95	140	212	90	1.8	17,5	11.0	10-Ø11	18,1	
MZEU80K E2+E7	5,170	800	200	1.38	80	22x5.4	144	146	210	254	100	160	232	105	1.8	20,0	11.0	10-Ø11	23,1	
MZEU 90 E2+E7	12,000	450	150	4.70	90	25x5.4	158	160	230	278	115	180	254	120	2.0	19,0	13.0	10-Ø14	28,1	
MZEU100 E2+E7	17,600	400	130	5.39	100	28x6.4	182	184	270	335	120	210	305	140	2.0	28,0	17.5	10-Ø18	46,3	
MZEU130 E2+E7	24,500	320	110	6.76	130	32x7.4	212	214	310	380	152	240	345	160	2.5	27,0	17.5	12-Ø18	70,2	
MZEU150 E2+E7	33,800	240	80	8.13	150	36x8.4	246	248	400	485	180	310	445	200	2.5	30,0	21.5	12-Ø22	146,3	

Note: For the dimensions: bore size, B and D<sub>1</sub> we recommend the tolerances H7 and h7 as stated in the table above.

**- installation and usage -**

1. This version of the MZEU-K Cam Clutch comes as a combination of a basic type clutch, an E7 and an E2 flange, each one packed and supplied as an individual part set.
2. Each flange set come with a complete mounting kit, containing a number of bolts, a grease nipple, a locker set screw and a seal plug.
3. Check the direction of rotation before assembling, then mount both flanges making use of the flange kit.
4. Before mounting the sizes MZEU90- MZEU150 apply the sealing adhesive, which comes along with the part sets, between body (outer race surface) and the optional part, to prevent leakage of oil during operation.

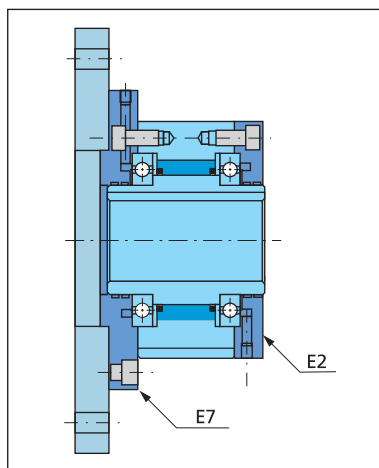

Installation example 6.

5. Always use bolts for installing a sprocket, a gear, pulley or other options to the clutch. Size and quantity of the bolts needed are mentioned under H-J on page 3. Length and shape of the bolts is determined by the thickness of the fitted part.
6. When installing any type of optional or fitted part in the opposite way the direction of the clutch's rotation can be changed.
7. For high speed indexing applications (over 50 c/min) strong springs are recommended and can be supplied accordingly.

8. Refer to page 10 for other usage indicators and further advise.



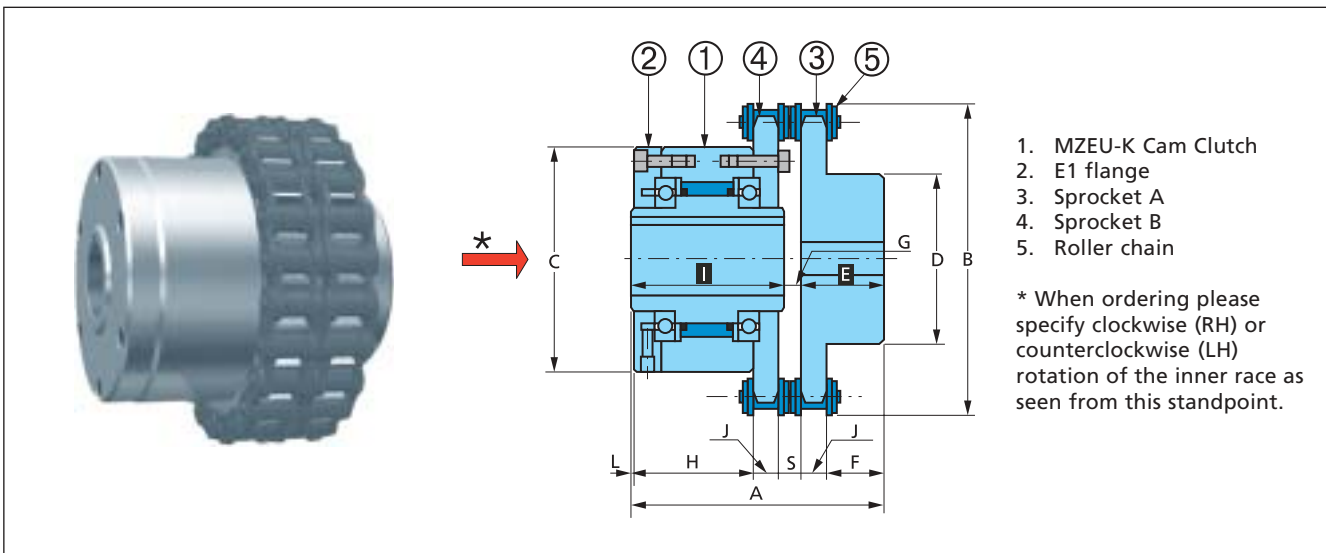

Summary of parts and dimensions (referring to table below).

**- dimensions and capacities -**

Model	Torque capacity N-m	Max. overrunning speed		Drag torque N-m	Clutch side		Coupling side		A	B	C	D	E	F	G	H	I	J	L	S
		Inner race r/min	Outer race r/min		Stock bore size H7	Keyway	Bore dia. range													
							min.	max.												
MZEU12K-C TK	60	2,000	1,000	0.20	12	4 x 1.8	14	45	70.6	93	62	67	25	17.8	3.6	30.0	42	7.2	1	7.4
MZEU15K-C TK	100	1,800	900	0.20	15	5 x 2.3	14	50	79.6	101	68	75	25	17.8	2.6	39.0	52	7.2	1	7.4
MZEU20K-C TK	245	1,600	700	0.29	20	6 x 2.8	14	42	85.1	109	75	63	25	17.8	3.1	44.5	57	7.2	1	7.4
MZEU25K-C TK	425	1,600	600	0.33	25	8 x 3.3	18	47	93.9	127	90	73	28	19.3	5.9	46.5	60	8.7	1	9.7
MZEU30K-C TK	735	1,500	500	0.39	30	8 x 3.3	18	47	101.9	137	100	73	28	19.3	5.9	54.5	68	8.7	1	9.7
MZEU35K-C TK	1,015	1,400	300	0.49	35	10 x 3.3	18	55	122.7	152	110	83	40	28.3	8.7	58.5	74	11.7	1	11.5
MZEU40K-C TK	1,350	1,400	300	0.59	40	12 x 3.3	20	55	132.7	164	125	83	40	28.3	6.7	68.5	86	11.7	1	11.5
MZEU45K-C TK	1,620	1,400	300	0.69	45	14 x 3.8	20	55	132.7	176	130	83	40	28.3	6.7	68.5	86	11.7	1	11.5
MZEU50K-C TK	2,070	1,300	250	0.79	50	14 x 3.8	20	55	142.2	200	150	83	40	28.3	8.2	78.0	94	11.7	1	11.5
MZEU55K-C TK	2,400	1,300	250	0.88	55	16 x 4.3	30	75	159.8	219	160	107	45	30.4	10.8	84.0	104	14.6	1	15.2
MZEU60K-C TK	2,950	1,200	250	0.98	60	18 x 4.4	30	75	170.8	235	170	107	45	30.4	11.8	95.0	114	14.6	1	15.2
MZEU70K-C TK	4,210	1,100	250	1.27	70	20 x 4.9	30	75	189.3	251	190	107	45	30.4	10.3	113.5	134	14.6	1	15.2
MZEU80K-C TK	5,170	800	200	1.38	80	22 x 5.4	30	75	196.8	267	210	107	45	30.4	7.8	121.0	144	14.6	1	15.2

Note: For the dimensions: stock bore size and C we recommend the tolerances H7 and h7 as stated in the table above.



MZEU-K-C series Cam Clutch couplings are combinations of standard MZEU-K Cam Clutches and CR type chain couplings.

**- installation and usage -**

1. Mount the Cam Clutch part loosely onto the high-speed shaft.
2. Accurately align both sprockets by checking with a straight edge on the teeth of both sprockets.
3. Check whether the clearance (S) between both sprockets is correct, then wrap the chain around the sprockets and close it properly with the connecting link.
4. Ensure that the closed side of the spring clip is situated in the same direction as the rotation of the outer race.

**- lubrication and maintenance -**

The basic models MZEU12K to MZEU80K are pre-greased and require no further lubrication. However, the lateral bearings need to be greased periodically. See the tables below for the recommended grease and frequency.

For higher range temperatures please consult Tsubaki. The basic models MZEU90 to MZEU150 and optional parts such as flanges, torque arm or cover need to be lubricated with oil at scheduled maintenance. See the tables below for the recommended oil and frequency.

The operational temperature range is -40°C to +40°C.

**Recommended grease for Cam Clutches MZEU12K to MZEU80K**

Oil company	Ambient temperature	
	- 5° C ~ + 40° C	- 40° C ~ + 40° C
Esso	Beacon 2	Beacon 325
Mobil	Mobilux Grease No. 2	Mobil temp SHC 100
Shell	Alvaria Grease No. 2	Alvaria Grease RA
BP	Energrease LS2	Energrease LT2
Total	Multis 2	Aerogrease 22

Note: Do not use grease containing EP additives when selecting any other brand or make.

**Recommended oil for Cam Clutches MZEU90 to MZEU150**

Oil company	Ambient temperature	
	- 10° C ~ + 30° C	+ 30° C ~ + 50° C
Esso	Telesso 32, Essolub D-3 10W, ATF Devon	Essolub D-3 30
Mobil	ATF 220, Delvac 1310, DTE Oil light	Delvac 1330
Shell	Dexron II, Rimula CT Oil 10W	Rimulla CT oil 20W/20, 30
	Shell Clavus Oil 17, Rotella S Oil 10W	Rotella S Oil 20W/20, 30
BP	BP Energol THB32	-
Gulf	Harmony 32, Veritas SD10	Veritas SD30

Note: Do not use oil containing EP additives when selecting any other brand or make.

**- instructions for lubrication of MZEU90 to MZEU150 -**

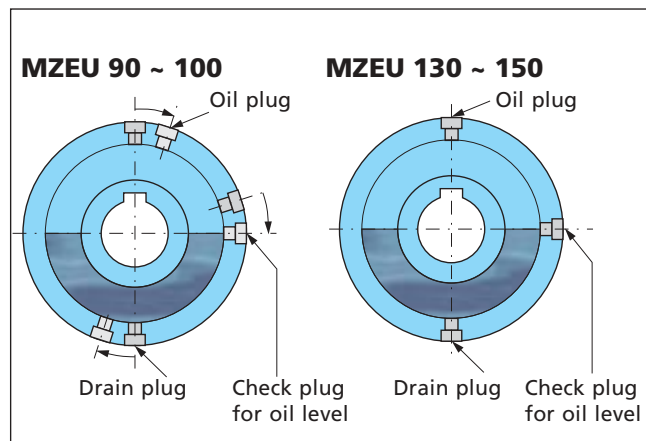
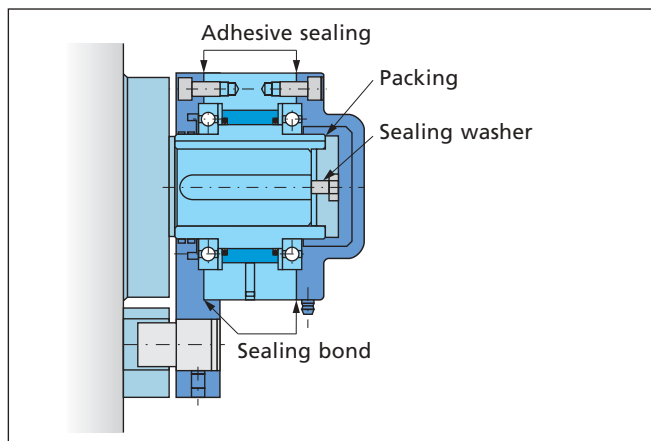

1. Apply a suitable amount of oil before use.
2. As a general rule, the amount of lubricant should be level with the center of the shaft for overrunning or backstopping.
3. The E2 flange has three plugs. The E4 cover has a large plug for adding oil and two small plugs for checking and draining.

4. Place the plugs, so that one is at the top and one is at the bottom. The center one should be level with the center of the shaft.
5. Pour oil into the clutch until it overflows from check plug. After a few minutes, pour in more oil and check that it overflows again.

**- maintenance -**

Model	Lubricant	Maintenance
MZEU 12 ~ MZEU 80	Grease	Every 3 months by the grease nipple on the flange, the torque arm and/or cover.
MZEU 90 ~ MZEU 150	Oil	Replace the oil 10 hours after the first installation. Then refresh the oil every 3 months. For dirty environments we recommend refreshment every month.

Tsubaki Emerson Cam Clutches can be used in numerous applications. At the last page of this booklet you will find a general view of the various series of Cam Clutches Tsubaki Emerson can provide from

stock. And if not at hand in the warehouses, your specific Cam Clutch can be made according to your specifications.



- warning -



**Use with care to prevent injury**

**Comply with the following to avoid serious personal injury**

1. Guards must be provided on all power transmission and conveyor applications in accordance with provisions of ANSI/ASME B 15.1 1992 and ANSI/ASME B 20.1 1993 or other applicable standards. When revisions of these standards are published, the updated edition shall apply.
2. Always lock out power switch before installing, removing, lubricating or servicing a system that uses Cam Clutch products.
3. If the Cam Clutch is used for repeated starting and stopping, make sure the strength of the supports for the Cam Clutch are sufficient.
4. The capacity of your Cam Clutch may be effected by the accuracy of its set up, the amount of pressure exerted on it, wear on other parts in your system, or wear life of the Cam Clutch itself. Check the Cam Clutch at regular intervals and observe any necessary safety precautions.
5. When connecting or disconnecting Cam Clutch products, eye protection is required. Wear safety glasses, protective clothing, gloves and safety shoes.

## - more Cam Clutches from Tsubaki Emerson -

Tsubaki Emerson developed many series of Cam Clutches to meet any industrial demand. Except for the series mentioned in this brochure you may need additional technical solutions to comply with your specific application. The bro-

chures shown below may give you an impression of the vast range of Cam Clutches we can deliver from stock and on customer specifications. Please do not hesitate to contact us for advice or further information.

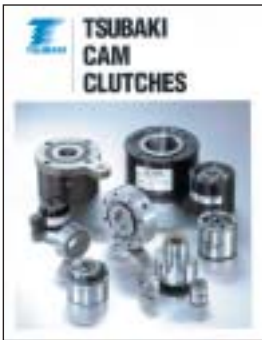

Tsubaki Emerson Cam Clutches are precision devices which lock the inner and outer races through the wedging action of cams to transmit torque in one direction of rotation and overrun in the opposite direction.

These units are often referred to as freewheels, sprag, overrunning, backstop, or one-way clutches, depending upon their application. In this brochure you will find the complete range of Cam Clutches according to Japanese and American standards.

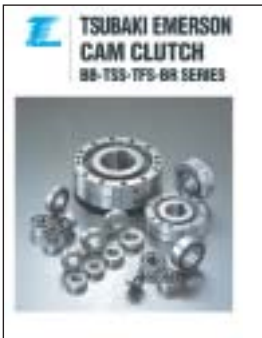

BB (build-in bearing) series Cam Clutches are available with and without keyways on inner race and/or outer race. Moreover the 2GD versions have special lip seals for effective protection against dust.

6200 series ball bearings, having keyway on the inner race as standard.

TFS series are similar to TSS, however their dimensions are the same as 6300 series bearings.

TSS series are non-bearing supported Cam Clutches and as BB series, dimensionally identical to

Both TSS and TFS series do require regular maintenance and lubrication as well as lateral bearing support.

BR series Cam Clutches are designed for backstop and overrunning applications with high speeds, having lift off designed cams ensuring a longer lifetime than any other type of clutch.

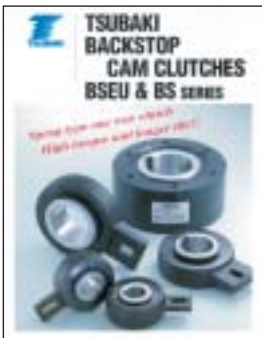

These series of Cam Clutches from Tsubaki Emerson are one-way clutches with the safest rotation prevention qualities available. They are manufactured for installations with low speed shaft rotations of inclined con-

veyors such as bucket and pivot elevators. Compared to other one-way clutches (ratchet or roller ramp clutch) similar in size, overheating during times when the motor is idling is significantly lower. This helps to maintain superb lubrication qualities thereby improving the wear life of the clutch. Extended fatigue life is also obtainable due to the clutch's large torque capacity.

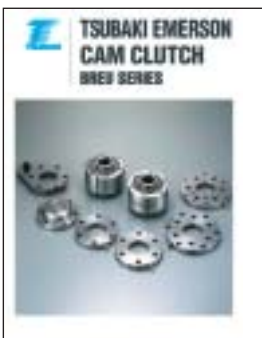

Cams of BREU series Cam Clutches are designed for a lift-off function, which results in a contactless overrunning stage between inner and outer races. This is due to the centrifugal force of the cam's shape in com-

ination with a special cam cage and a minimum speed applied. They are used for backstop and overrunning applications at higher speeds than conventional clutches can absorb. The clutch's features and design ensure a maintenance free operation and considerable extended lifespan in comparison to any other type of clutch available in the market.

For more information please contact:

TSUBAKIMOTO EUROPE B.V. - Belder 1 - NL 4704 RK Roosendaal - the Netherlands  
Tel. +31 (0)165 59 48 00 - Fax +31 (0)165 54 94 50 - E-mail info@tsubaki.nl - Internet <http://tsubakimoto.com>

