

www.bergab.ru Берг АБ bergab@ya.ru Тел. (495)-228-06-21, факс (495) 223-3071

COMPACT AND BACKLASH FREE.

single-position
multi-position
load holding
full disengagement

TORQUE LIMITERS

SERIES SK | 0.1 – 2,800 Nm



NEW TORQUE RANGES

R+W[®]
COUPLING TECHNOLOGY

THE ULTIMATE COUPLING FROM 0.1 – 2,800 Nm

www.bergab.ru Берг АБ bergab@ya.ru Тел. (495)-228-06-21, факс (495) 223-3071

www.rwcouplings.com



SK SERIES

PATENTED BACKLASH-FREE TORQUE LIMITERS FROM R+W

Reliable Torque Overload Protection

The trend in industry is to design and incorporate more automation into production processes. Machines are becoming more accurate, requiring a higher degree of precision. They are becoming faster, using servo and DC drive technology, and they are more rigid to withstand the dynamic loads necessary to increase capacity and productivity.

Torque overloads caused by material jams, operator error, or a whole host of unforeseen reasons pose a significant threat to machine downtime.

Machine downtime in an automated production environment is very costly. Broken components, expensive technicians, and long lead times for custom components can make the difference between operating profitably or not. Torque overload couplings are an inexpensive insurance against downtime.

This catalog contains many different torque overload coupling designs. They all incorporate the patented R+W design principle. The couplings are all torsionally rigid with absolute zero backlash.

The use of a patented R+W Torque Limiter will isolate the driving from the driven elements within a matter of milliseconds, once the torque reaches a preset overload value. Incorporating **R+W Torque limiting couplings** into modern machine design will help insure high productivity and higher profits.



Areas of application

- Machine tools
- CNC machining centers
- Woodworking machines
- Automation equipment
- Textile machinery
- Industrial robots
- Sheet metal processing machines
- Printing + Converting machinery
- Servo + DC motor drives

Features

- Precise overload protection
- Absolutely backlash-free and torsionally rigid (R+W patented principle)
- Compact, simple design
- Disengagement detection is achieved through indexing ring movement
- Low residual friction following disengagement
- Low moment of inertia
- Disengagement within msec

Table of contents

Coupling designs	Page 3
Overview of possible function systems	Page 4/5
Torque limiter model SK 1 / SKP Single-position, multi-position, load holding, full disengagement versions	Page 6/7
Torque limiter model SK 2 Single-position, multi-position, load holding, full disengagement versions	Page 8
Torque limiter model SK 3 Single-position, multi-position, load holding, full disengagement versions	Page 9
Torque limiter model SK 5 Single-position, multi-position, load holding, full disengagement versions	Page 10/11
Accessories	Page 12
General function	Page 13/14
Assembly and disassembly	Page 15
Important additional information	Page 16
Selection	Page 17/18
Important additional information	Page 19
Product range	Page 20

MODELS

FEATURES

POSSIBLE APPLICATIONS

SK 1 / SKP



With conical clamp or clamping hub

- Integral bearings for timing belt pulley or sprocket gear
- Compact, simple design
- Adjustable settings

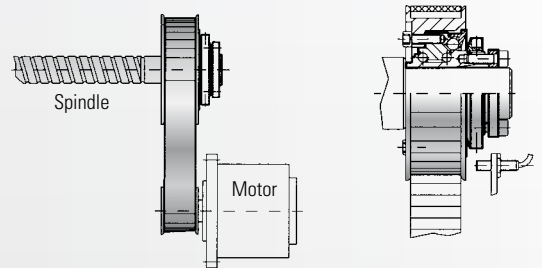

SK 2



With clamping hub for direct drives

- Easy assembly
- Low moment of inertia
- Small installation space
- Compensates for shaft misalignment
- Adjustable settings

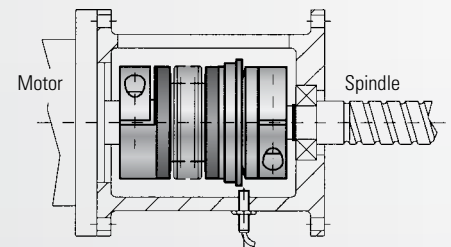

SK 3



With conical clamp connection for direct drives

- High clamping forces
- High degree of operational dependability
- Compensates for shaft misalignment
- Adjustable settings

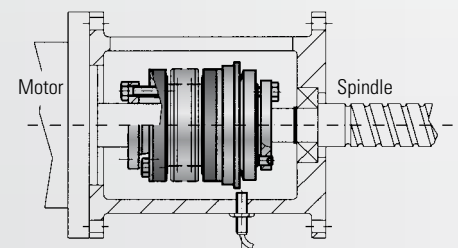

SK 5



With clamping hub, press-fit version for direct drives

- Easy mounting and dismounting
- Electrically and thermally insulated
- Compensates for shaft misalignment
- Adjustable settings

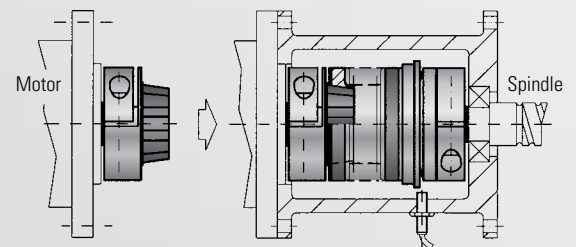

ES 2



With clamping hub, press-fit version for direct drives

- Easy assembly
- Dampens vibrations
- Compensates for shaft misalignment
- Adjustable settings

(see separate catalog)

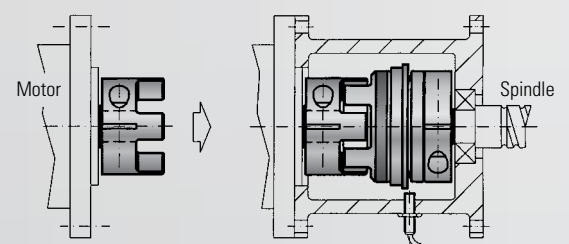



OVERVIEW

PATENTED BACKLASH-FREE TORQUE LIMITERS FROM R+W

Single-position re-engagement

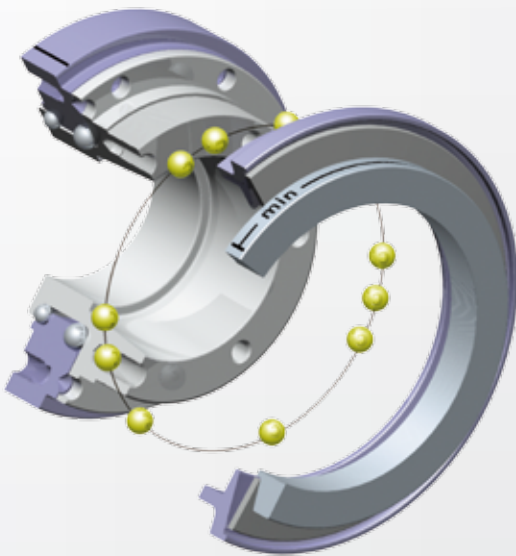

Standard version

- After the overload has been removed, the coupling will reengage precisely 360° from the original disengagement position.
- Signal at overload
- Suitable for use, in machine tools, packing machines and automation systems and other applications requiring precise timing.



Every model in this catalog is available in all 4 versions.

R+W TORQUE

Load holding Version

- Torque measurement coupling
- In the event of a torque overload, the drive and driven elements are not separated and are only allowed limited rotation.
- Guaranteed to hold the load and signal an overload.
- Automatic engagement after the torque level has dropped.
- Signal at overload to detect with mechanical switch or proximity sensor.
- Suitable for use, on presses, load lifting equipment or on any applications where the drive and driven elements cannot be separated.

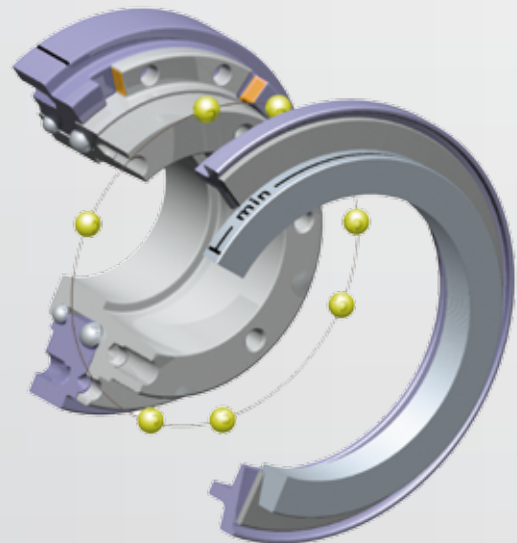

POSSIBLE FUNCTION SYSTEMS

Multi-position coupling

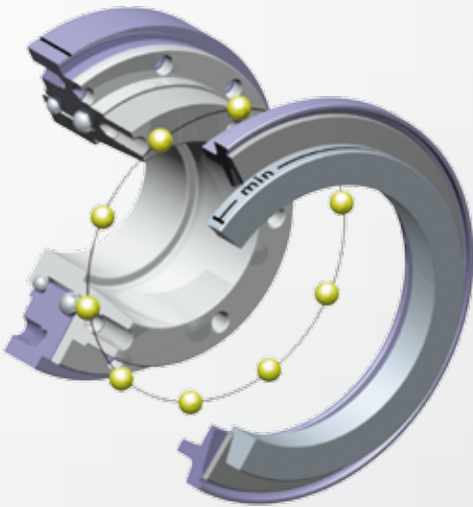

- Coupling re-engages at multiple set angular intervals.
- Immediate availability of the machine as soon as the overload has been removed.
- Signal at overload with mechanical switch or proximity sensor
- Standard engagement every 60°
- Engagement after 30, 45, 90 and 120 degrees optional

E LIMITERS

Full disengagement

Indication:
Coupling can be
disengaged
manually.
Please contact
R+W.

- Permanent separation of drive and driven face in the event of a torque overload.
- Signal at overload with mechanical switch or proximity sensor
- No residual friction
- Rotating elements slow down freely
- Coupling can be re-engaged manually (Engagement every 60°); other engagements optional
- For use in high dynamic applications

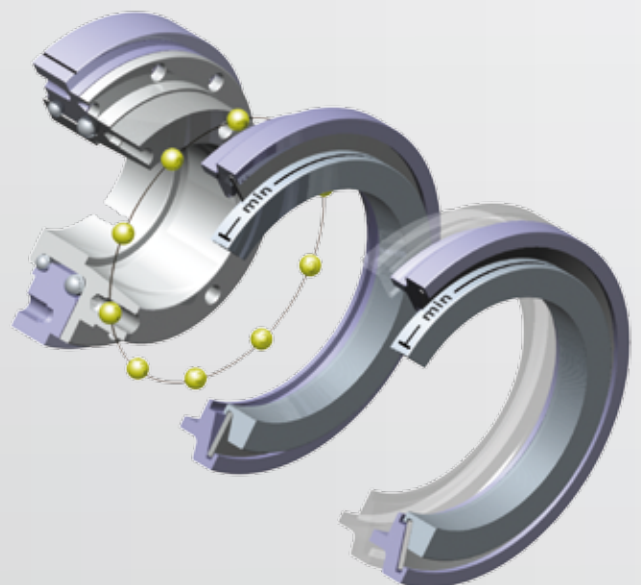



single position
multi-position
load holding
full disengagement



Model SK1

MODEL SK1/SKP

BACKLASH FREE TORQUE LIMITER

with conical clamp connection

Miniature Design Series 1.5 - 10

SK 1 with clamping hub

SKP with a pure key connection

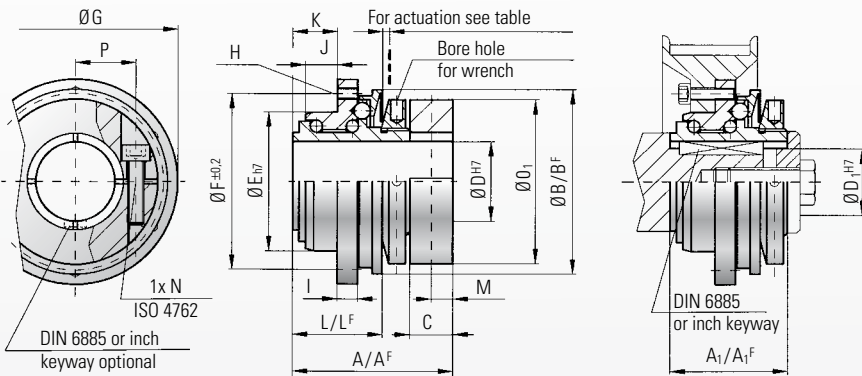

Material

High-strength steel

Design

Model SK1 from 1.5-10 Nm with clamping hub
Model SK1 from 15-2,800 Nm with conical clamp
Optional clamping hub available upon request

Model SKP with pure keyway connection

Temperature range:

-30° C to +120° C
Temperature peaks up to + 150° C

Backlash:

Absolutely backlash-free as a result of the frictional clamp connection and the patented R+W principle

Service life:

These couplings are maintenance-free and have extreme service life as long as all the performance units are not exceeded.

Optional sealed version for wash down and foodservice application. See page 16

Design Series 15-2,500

SK 1 with conical clamp

SKP with a pure key connection

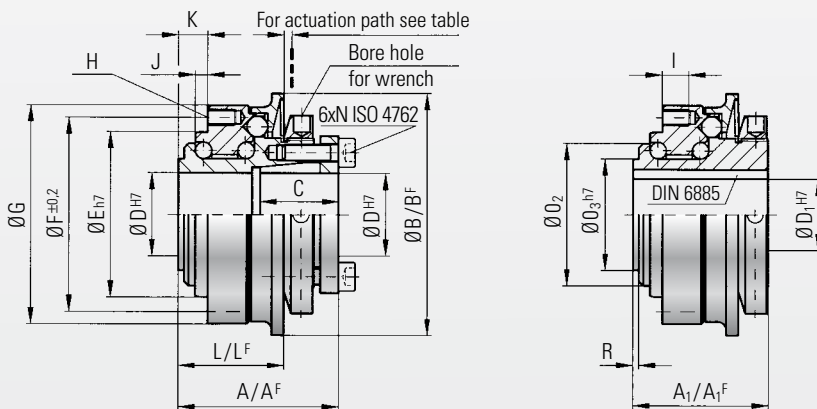

Ordering specifications

SK1 / 10 / W / 14 / 4 / 2-6 / xx

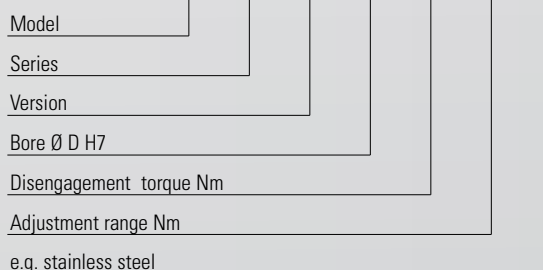

Possible versions

- W = Single-position engagement
- D = Multi-position engagement
- G = Load holding
- F = Full disengagement

For the maximum permissible radial load capacity for all SK 1 / SKP models, see installation instructions on page 14



single position
multi-position
load holding
full disengagement



Model SKP

with pure keyway connection

Model SK 1/SKP		Miniature Design													
		Series													
		1.5	2	4.5	10	15	30	60	150	200	300	500	800	1500	2500
Adjustment range possible from - to (approx. values) (Nm)	T_{KN}	0.1-1 or 0.3-2	0.2-1.5 or 0.5-2.2 or 1.5-3.5	1-3 or 2-4.5 or 3-7	2-6 or 4-12 or 7-18	5-15 or 12-25 or 20-40 or 35-70	5-20 or 10-30 or 20-60 or 50-100	10-30 or 25-80 or 50-115	20-70 or 45-150 or 80-225	30-90 or 60-200 or 140-280 or 250-400	100-200 or 150-240 or 220-440	80-200 or 200-350 or 320-650	400-650 or 500-800 or 650-950	600-800 or 700-1200 or 1000-1800	1500-2000 or 2000-2500 or 2300-2800
Adjustment range possible from - to (approx. values) (full disengagement) (Nm)	T_{KN}^F	0.3-0.8 or 0.6-1.3	0.5-2	2.5-4.5	2-5 or 4-10 or 8-15	7-15	8-20 or 16-30	10-30 or 20-40 or 30-60	20-60 or 40-80 or 80-150	80-140 or 130-200	120-180 or 130-300	50-150 or 100-300 or 250-500	200-400 or 450-850	1000-1250 or 1250-1500	1400-2200 or 1800-2700
Overall length (mm)	A	23	28	32	39	40	50	54	58	63	70	84	95	109	146
Overall length (full disengagement) (mm)	A^F	23	28	32	39	40	50	54	58	66	73	88	95	117	152
Overall length A1 (mm)	A_1	15.5	20	22	28	34	43	46	48.5	54	57	71.5	80	93	135
Overall length A1 (full disengagement) (mm)	A_1^F	15.5	20	22	28	34	43	46	48.5	57	60	75	91	110	141
Actuation ring Ø (mm)	B	23	29	35	45	55	65	73	92	99	120	135	152	174	242
Actuation ring Ø (full disengagement) (mm)	B^F	24	32	42	51.5	62	70	83	98	117	132	155	177	187	258
Clamping fit length (mm)	C	7	8	11	11	19	22	27.5	32	32	41	41	49	61	80
Inner diameter from Ø bis Ø H7 (mm)	D	4-8	4-12	5-14	6-20	8-22	12-22	12-29	15-37	20-44	25-56	25-56	30-60	35-70	50-100
Inner diameter max. Ø H7 (mm)	D_1	8	10	12	16	19	25.4	30	38	44	50	58	60	73	95
Centering diameter h7 (mm)	E	14	22	25	34	40	47	55	68	75	82	90	100	125	168
Hole circle diameter ± 0.2 (mm)	F	22	28	35	43	47	54	63	78	85	98	110	120	148	202
Flange diameter -0.2 (mm)	G	26	32	40	50	53	63	72	87	98	112	128	140	165	240
Thread	H	4xM2	4xM2.5	6xM2.5	6xM3	6xM4	6xM5	6xM5	6xM6	6xM6	6xM8	6xM8	6xM10	6xM12	6xM16
Thread length (mm)	I	3	4	4	5	6	8	9	10	10	10	12	15	16	24
Centering length -0.2 (mm)	J	2.5	3.5	5	8	3	5	5	5	5	6	9	10	13.5	20
Distance (mm)	K	5	6	8	11	8	11	11	12	12	15	21	19	25	34
Distance (mm)	L	11	15	17	22	27	35	37	39	44	47	59	67	82	108
Distance (mm)	L^F	11.5	16	18	23	27	37	39	41.5	47	51.5	62	75	91	120
Distance (mm)	M	2.5	5	4	5										
Screw ISO 4762	N	M2.5	M3	M4	M4	M4	M5	M5	M6	M6	M8	M8	M10	M12	M16
Tightening torque in (Nm)		1	2	4	4.5	4	4	7	12	14	18	25	36	70	120
Outside diameter clamp ring (mm)	O_1	20	25	32	40										
Diameter (mm)	O_2	13	18	21	30	35	42	49	62	67	75	84	91	112	154
Diameter h7 (mm)	O_3	11	14	17	24	27	32	39	50	55	65	72	75	92	128
Distance between centers (mm)	P	6.5	8	10	15										
Distance (mm)	R	1	1.3	1.5	1.5	2.5	2.5	2.5	2.5	3	3	4	4	4.5	6
Moment of inertia (10^{-3} kgm ²)	J_{ges}	0.01	0.02	0.05	0.07	0.15	0.25	0.50	1.60	2.70	5.20	8.60	20	31.5	210
Approx. weight (kg)		0.03	0.065	0.12	0.22	0.4	0.7	1.0	1.3	2.0	3.0	4.0	5.5	10	28
Actuation path (mm)		0.7	0.8	0.8	1.2	1.5	1.5	1.7	1.9	2.2	2.2	2.2	2.2	3.0	3.0

A^F, B^F, L^F = Full disengagement version



single position
multi-position
load holding
full disengagement



with clamping hub

MODEL SK2

BACKLASH FREE TORQUE LIMITER

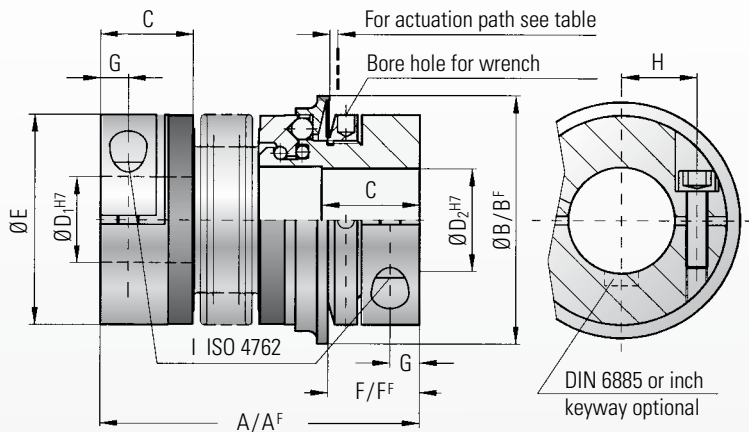

Optional sealed version for wash down and food service application. See page 16.

Material:

Bellows made of highly elastic stainless steel
Safety section: High strength hardened steel
Hub material: up to series 80 aluminium from series 150 steel

Design:

With a single radial clamping screw per hub

Temperature range:

-30° C to +120° C

Backlash:

Absolutely backlash free as a result of the frictional clamp connection and the patented R+W principle

Service life:

These coupling are maintenance free and have extreme service life as long as the performance limits are not exceeded.

Fit tolerance:

Tolerance between hub and shaft 0.01-0.05 mm

Ordering specifications:

see page 11

Model SK 2		Series																										
		1.5	2		4.5		10		15		30		60		80		150		200		300		500		800		1500	
Adjustment range possible from - to (approx. values) (Nm)	T _{KN}	0.1-0.6 0.4-1 0.8-1.5	0.2-1.5 or 0.5-2		1-3 or 3-6		2-6 or 4-12		5-20		10-25 or 20-40		10-30 or 25-80		20-70 or 30-90		40-160		30-90 60-160 150-240 200-320		80-200 200-350 300-500		400-650 500-800 650-850		650-800 700-1200 1000-1800			
Adjustment range possible from - to (approx. values) (full disengagement) (Nm)	T _{KN}	0.3-0.8 or 0.6-1.3	0.5-2		2.5-4.5		2.5 or 5-10		7-15		8-20 or 16-30		20-40 or 30-60		20-60 or 40-80		80-150		80-140 or 130-200		120-180 or 180-300		60-150 or 250-500		200-400 or 450-800		1000-1250 or 1250-1500	
Overall length (mm)	A	42	46	51	57	65	65	74	75	82	87	95	102	112	115	127	116	128	128	140	139	153	163	177	190	223		
Overall length, (full disengagement) (mm)	A ^F	42	46	51	57	65	65	74	75	82	87	95	102	112	117	129	118	130	131	143	142	156	167	181	201	232		
Actuation ring Ø (mm)	B	23	29		35		45		55		65		73		92		92		99		120		135		152		174	
Actuation ring Ø (full disengagement) (mm)	B ^F	24	32		42		51.5		62		70		83		98		98		117		132		155		177		187	
Fit length (mm)	C	11	13		16		16		22		27		31		35		35		40		42		51		48		67	
Inner diameter from Ø to Ø H7 (mm)	D ₁ /D ₂	3-8	4-12		5-14		6-20		10-26		12-30		15-32		19-42		19-42		24-45		30-60		35-60		40-75		50-80	
Outer diameter of coupling (mm)	E	19	25		32		40		49		55		66		81		81		90		110		123		134		157	
Distance (mm)	F	12	13		15		17		19		24		30		31		31		35		35		45		50		63	
Distance (full disengagement) (mm)	F ^F	11.5	12		14		16		19		22		29		31		30		33		35		43		54		61	
Distance (mm)	G	3.5	4		5		5		6.5		7.5		9.5		11		11		12.5		13		17		18		22.5	
Distance between centers (mm)	H	6	8		10		15		17		19		23		27		27		31		39		41		2x48		2x55	
ISO 4762 screws	I	M2.5	M3		M4		M4		M5		M6		M8		M10		M10		M12		M12		M16		2xM16		2xM20	
Tightening torque (Nm)	I	0.85	2		4		4.5		8		15		40		50		70		120		130		200		250		470	
Approx. weight (kg)		0.035	0.07		0.2		0.3		0.4		0.6		1.0		2.0		2.4		4.0		5.9		9.6		14		21	
Moment of inertia (10 ⁻³ kgm ²)	J _{ges}	0.01	0.01	0.01	0.02	0.02	0.06	0.07	0.10	0.15	0.27	0.32	0.75	0.80	1.80	1.90	2.50	2.80	5.10	5.30	11.5	11.8	22.8	23.0	42.0	83.0		
Torsional stiffness (10 ⁹ Nm/rad)	C _T	0.07	1.2	1.3	7	5	9	8	20	15	39	28	76	55	129	85	175	110	191	140	420	350	510	500	780	1304		
Lateral misalignment max. (mm)		0.15	0.15	0.20	0.20	0.25	0.20	0.30	0.15	0.20	0.20	0.25	0.20	0.25	0.20	0.25	0.20	0.25	0.20	0.25	0.25	0.30	0.25	0.30	0.30	0.35	0.35	0.35
Angular misalignment max. (degrees)		1	1	1.5	1.5	2	1.5	2	1	1.5	1	1.5	1	1.5	1	1.5	1	1.5	1.5	2	1.5	2	2	2.5	2.5	2.5		
Lateral spring stiffness (N/mm)		70	40	30	290	45	280	145	475	137	900	270	1200	420	920	255	1550	435	2040	610	3750	1050	2500	840	2000	3600		
Actuation path (mm)		0.7	0.8		0.8		1.2		1.5		1.5		1.7		1.9		1.9		2.2		2.2		2.2		2.2		3	

A^F, B^F, F^F = Full disengagement version

(smaller sizes on request)



single position
multi-position
load holding
full disengagement



MODEL SK3

BACKLASH FREE TORQUE LIMITER

with tapered clamp connection

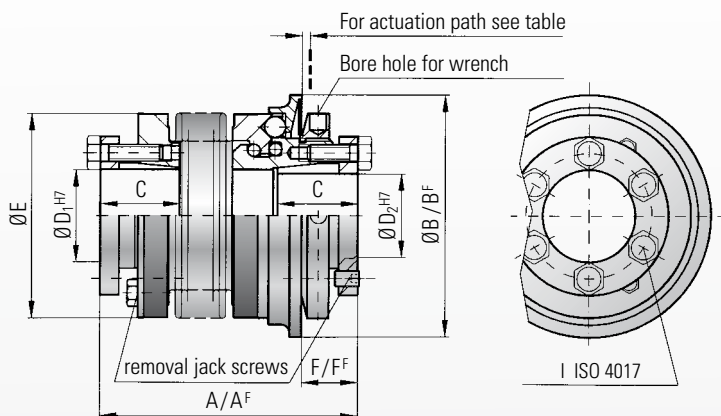

Optional sealed version for wash down and foodservice application. See page 16.

Material:

Bellows made of highly elastic stainless steel
Safety section: High strength hardened steel.
Hub material: Steel

Design:

With slotted tapered conical sleeves and removal jack screws

Temperature range:

-30° C to +120° C

Backlash:

Absolutely backlash free as a result of the frictional clamp connection and the patented R+W principle

Service life:

These coupling are maintenance free and have extreme service life as long as the performance limits are not exceeded.

Fit tolerance:

Tolerance between hub and shaft 0.01-0.05 mm

Ordering specifications:

see page 11

Model SK 3		Series																			
		15		30		60		150		200		300		500		800		1500		2500	
Adjustment range possible from (approx. values) (Nm)	T_{KN}	5-20		10-25 or 20-40		10-30 or 25-80		20-70 45-150 80-200		30-90 60-160 140-280		100-200 150-240 220-400		80-200 200-350 300-500		400-650 500-800 600-900		650-850 700-1200 1000-1800		1500-2000 2000-2500 2300-2800	
Adjustment range possible from (approx. values) (full disengagement) (Nm)	T_{KN}	7-15		8-20 or 16-30		20-40 or 30-60		20-60 40-80 80-150		80-140 or 130-200		120-180 or 180-300		60-150 100-300 250-500		200-400 or 450-800		1000-1250 or 1250-1500		1400-2200 or 1800-2700	
Overall length (mm)	A	62	69	72	80	84	94	93	105	99	111	114	128	123	136	151	175	175	246	246	
Overall length (full disengagement) (mm)	A ^F	62	69	72	80	84	94	93	105	102	114	117	131	127	140	151	184	184	252	252	
Actuation ring Ø (mm)	B	55		65		73		92		99		120		135		152		174		243	
Actuation ring Ø (full disengagement) (mm)	B ^F	62		70		83		98		117		132		155		177		187		258	
Fit length (mm)	C	19		22		27		32		32		41		41		49		61		80	
Inner diameter from Ø to Ø H7 (mm)	D ₁ /D ₂	10-22		12-23		12-29		15-37		20-44		25-56		25-60		30-60		35-70		50-100	
Outer diameter of coupling (mm)	E	49		55		66		81		90		110		123		133		157		200	
Distance (mm)	F	13		16		18		19		19		23		25		31		30		37	
Distance (full disengagement) (mm)	F ^F	13		14		17		18		17		20		22		20		26		31	
6x ISO 4017	I	M4		M5		M5		M6		M6		M8		M8		M10		M12		M16	
Tightening torque (Nm)	I	4		6		8		12		14		18		25		40		70		120	
Approx. weight (kg)		0.3		0.4		1.2		2.3		3.0		5.0		6.5		9.0		16.3		35	
Moment of inertia (10 ⁻³ kgm ²)	J _{ges}	0.10	0.15	0.28	0.30	0.75	0.80	1.90	2.00	2.80	3.00	5.50	6.00	11.0	12.8	20.00	42.00	42.00	257	257	
Torsional stiffness (10 ³ Nm/rad)	C _T	20	15	39	28	76	55	175	110	191	140	420	350	510	500	780	1304	1304	3400	3400	
Lateral misalignment max. (mm)		0.15	0.20	0.20	0.25	0.20	0.25	0.20	0.25	0.25	0.30	0.25	0.30	0.30	0.35	0.35	0.35	0.35	0.35	0.35	
Angular misalignment max. (degrees)		1	1.5	1	1.5	1	1.5	1	1.5	1.5	2	1.5	2	2	2.5	2.5	2.5	2.5	2.5	2.5	
Lateral spring stiffness (N/mm)		475	137	900	270	1200	380	1550	435	2040	610	3750	1050	2500	840	2000	3600	3600	6070	6070	
Actuation path (mm)		1.5		1.5		1.7		1.9		2.2		2.2		2.2		2.2		3		3	

A^F, B^F, F^F = Full disengagement version



single position
multi-position
load holding
full disengagement



MODEL SK5

BACKLASH FREE TORQUE LIMITER

press-fit version, with clamping hub

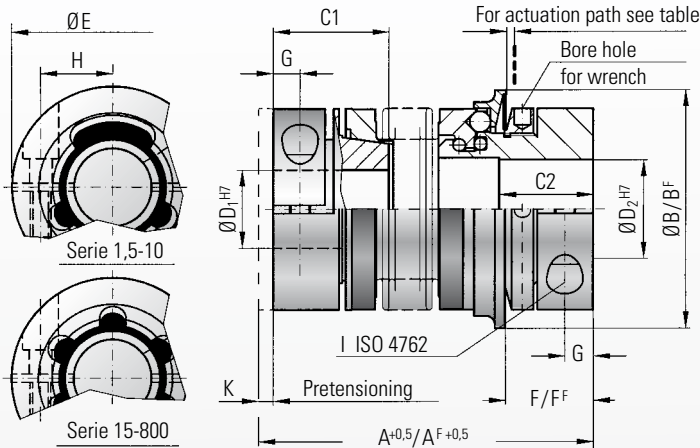

Optional sealed version for wash down and foodservice application. See page 16.

Material:

Bellows made of highly elastic stainless steel
Safety section: High strength hardened steel

Clamping hubs:

up to series 80 aluminium from series 150 steel

Design:

With a single radial clamping screw per hub

Temperature range:

-30° C to +120° C

Backlash:

Absolutely backlash free as a result of the frictional clamp connection and the patented R+W principle

Service life:

These couplings are maintenance free and have extreme service life as long as the performance limits are not exceeded.

Fit tolerance:

Tolerance between hub and shaft 0.01-0.05 mm

Ordering specifications:

Page 11

Model SK 5	Series																									
	1.5	2	4.5	10	15	30	60	80	150	300	500	800														
Adjustment range possible from - to (approx. values) (Nm)	0.1-0.6 0.4-1 0.8-1.5		0.2-1.5 or 0.5-2		1-3 or 3-6		2-6 or 4-12		5-20		10-25 or 20-40		10-30 or 25-80		20-70 or 30-90		40-160		100-200 150-240 200-320		80-200 200-350 300-500		400-650 500-800 650-850			
Adjustment range possible from - to (approx. values) (full disengagement) (Nm)	0.3-0.8 or 0.6-1.3		0.5-2		2.5-4.5		2-5 or 5-10		7-15		8-20 or 16-30		20-40 or 30-60		20-60 or 40-80		80-150		120-200 or 160-300		60-150 100-300 250-500		200-400 or 450-800			
Overall length +0,5 inserted (mm)	A		44		48 54		60 68		70 79		76 83		89 97		105 115		115 127		116 128		143 157		166 180		196	
Overall length +0,5 inserted (full disengagement) (mm)	AF		44		48 54		60 68		70 79		76 83		89 97		105 115		117 129		118 130		146 160		170 184		207	
Actuation ring Ø (mm)	B		23		29		35		45		55		65		73		92		92		120		135		152	
Actuation ring Ø (full disengagement) (mm)	BF		24		32		42		51.5		62		70		83		98		98		132		155		176	
Fit length C1/C2 (mm)	C1/C2		14 11		16/13		19/16		21/16		28/22		33/27		39/31		43/35		43/35		52/42		61/52		74/48	
Inner diameter from Ø to Ø H7 (mm)	D1		3-8		4-12		5-16		5-20		8-22		10-25		12-32		14-38		14-38		30-56		35-60		40-75	
Outer diameter from Ø to Ø H7 (mm)	D2		3-8		4-12		5-14		5-20		8-26		10-30		12-32		14-42		14-42		30-60		35-60		40-75	
Outer diameter of coupling (mm)	E		19		25		32		40		49		55		66		81		81		110		123		134	
Distance (mm)	F		12		13		15		17		19		24		30		31		31		35		45		50	
Distance (full disengagement) (mm)	FF		11.5		12		14		16		19		22		29		31		30		36		43		54	
Distance (mm)	G		3.5		4		5		5		6.5		7.5		9.5		11		11		13		17		18	
Distance between centers (mm)	H		6		8		10		15		17		19		23		27		27		39		41		2x48	
ISO 4762 screws	I		M2.5		M3		M4		M4		M5		M6		M8		M10		M10		M12		M16		2xM16	
Tightening torque (Nm)	I		0.85		2		4		4.5		8		15		40		50		70		130		200		250	
Pretensioning, approx. (N)	K		0.1 to 0.5		0.2 to 0.7		0.2 to 0.7		0.2 to 1.0		0.2 to 1.0		0.5 to 1.0		0.5 to 1.0		0.5 to 1.0		0.5 to 1.0		0.5 to 1.5		0.5 to 2.0		0.5 to 2.0	
Axial recovery of coupling max. (N)			4		8 5		15 10		25 30		20 12		50 30		70 45		48 32		82 52		157 106		140 96		200	
Approx. weight (kg)			0.038		0.07		0.2		0.3		0.4		0.6		1.4		2		2.4		5.9		9.6		15	
Moment of inertia (10 ⁻³ kgm ²)	Jges		0.01		0.01 0.01		0.02 0.02		0.06 0.07		0.10 0.15		0.27 0.32		0.75 0.80		1.80 1.90		2.50 2.80		6.50 7.00		13.0 17.0		50	
Torsional stiffness (10 ³ Nm/rad)	CT		0.7		1.2 1.3		7 5		8 7		12 10		18 16		40 31		68 45		90 60		220 190		260 250		390	
Lateral misalignment max. (mm)			0.15		0.15 0.20		0.20 0.25		0.20 0.30		0.15 0.20		0.20 0.25		0.20 0.25		0.20 0.25		0.20 0.25		0.25 0.30		0.30 0.35		0.35	
Angular misalignment max. (degrees)			1		1 1.5		1.5 2		1.5 2		1 1.5		1 1.5		1 1.5		1 1.5		1 1.5		1.5 2		2 2.5		2.5	
Lateral spring stiffness (N/mm)			70		40 30		290 45		280 145		475 137		900 270		1200 420		920 290		1550 435		3750 1050		2500 840		2000	
Actuation path (mm)			0.7		0.8		0.8		1.2		1.5		1.5		1.7		1.9		1.9		2.2		2.2		2.2	

AF, BF, FF = Full disengagement version



single position
multi-position
load holding
full disengagement



press-fit version, with clamping hub

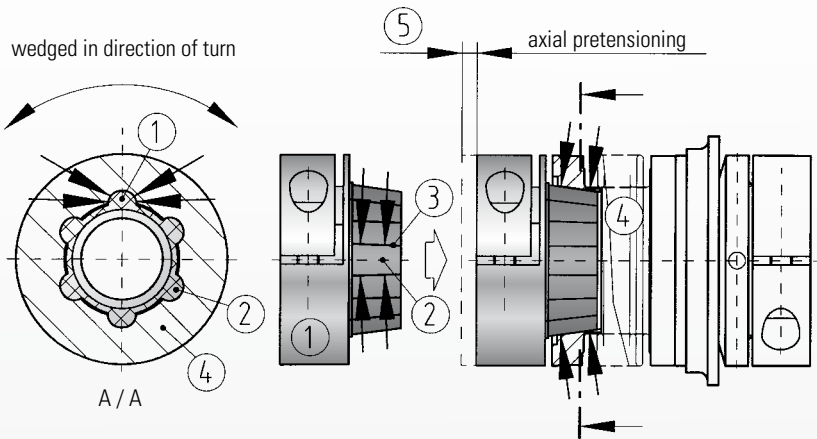

Design details

Six self-centering, tapered drive projections (2) have been formed into the conical element, which has been molded onto an aluminium hub (1).

The six axially arranged projections are configured conically in a longitudinal direction (3). The mating-piece consists of a metal bellows with a female tapered mounting segment (4).

Absolutely backlash-free torque transmission is ensured due to the axial pretensioning (5) of the metal bellows during mounting. This slight pretensioning has no negative influence on the operation of the metal bellows or on the shaft bearing.

Possible applications for backlash-free, press-fit torque limiter SK 5

1 Applications with limited accessibility. The dismantling of a single-piece coupling is too labor intensive.

2 The **press fit design** allows the complete drive unit to be removed by simply pulling it out when servicing is required.

Dismounting the coupling is possible **without loosening** the hub fastening screws. Therefore, clamping screw access holes are not required.

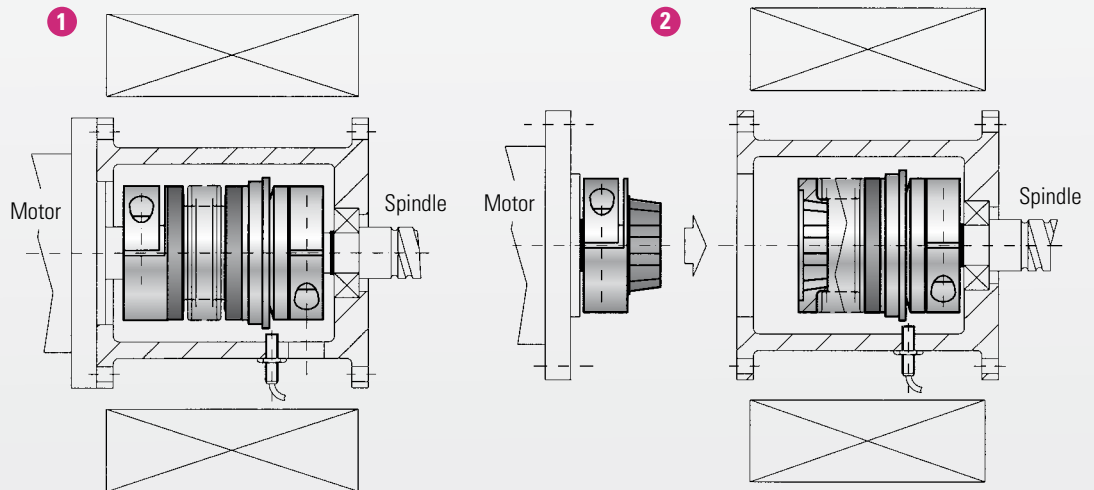

Ordering specifications

SK2 / 60 / 102 / D / 16 / 19 / 25/10-30/XX

Required information for models SK 2, SK 3 and SK 5

- Model
- Series
- Overall length (mm)
- Version
- Bore Ø D1 H7
- Bore Ø D2 H7
- Disengagement torque (Nm)
- Adjustment range (Nm)
- e.g. stainless steel

Possible versions:

- W = single position
- D = multi position
- G = Load holding
- F = Full disengagement



ACCESSORIES

PATENTED BACKLASH-FREE TORQUE LIMITERS FROM R+W

Torque adjusting wrench for DIN 1816 nuts

Order-No.: see table

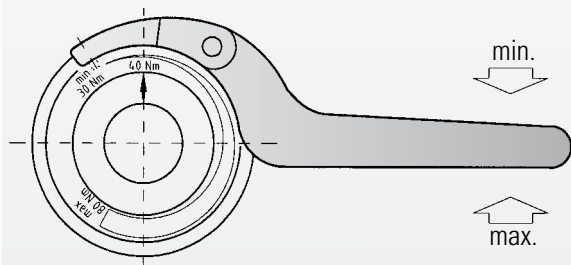

Small coupling sizes do not require a wrench. The adjusting nuts for series 1.5 / 2 / 4.5 / 10 can be adjusted with a bolt.

Coupling series			Wrench
15			Order-No. 60/4
20/30	40/60	80/150	Order-No. 90/5
200			Order-No. 90/6
300			Order-No. 155/6
500			Order-No. 155/8
800	1500	2500	Order-No. 230/8

Mechanical switch for Emergency Cut-Off (appropriate from series 10 on)

Order-No.: 618.6740.425

Technical drawing

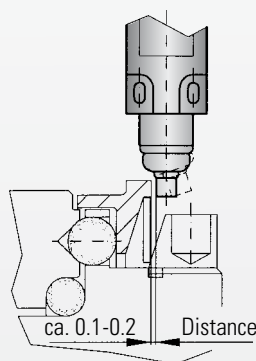
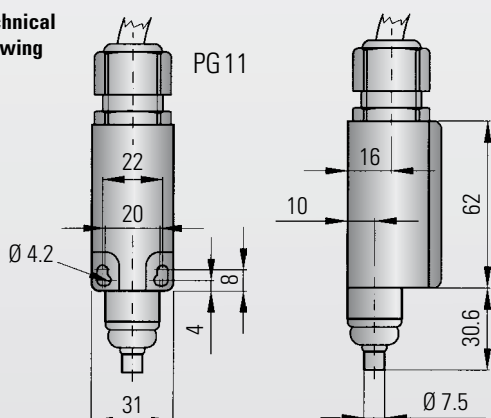

Technical data

Max. voltage:	500 V AC
Max. constant current:	10 A
Protective System:	IP 65
Contact system:	Opener (forced separating)
Ambient temperature:	- 30° C - +80 °C
Actuation:	Tappet (metal)

Switch diagram:



Important:

Upon assembly, it is absolutely necessary to check the function of the switch 100%.

The actuation tappet should be put as close as possible to the actuation ring of the torque limiter (approx. 0.1-0.2)

Proximity switch for Emergency cut-off

Order-No.: 650.2703.001

Technical drawing

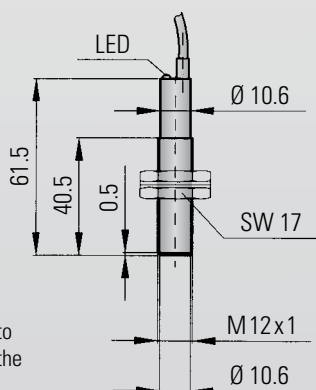

Important:

Upon assembly, it is absolutely necessary to check the function of the switch 100%.

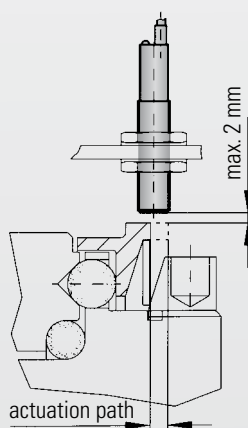

Technical data

Voltage:	10 bis 30 V DC
Output current:	200 mA
Switch frequency:	800 Hz
Temperature range:	-25°C bis +70°C
Protective System:	IP 67
Switch Type:	normally open
Max. detection gap:	max. 2 mm

Switch diagram:

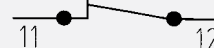

GENERAL FUNCTION

R+W torque limiting couplings are ball detent style overload couplings. They protect drive and driven mechanical components from damage associated with torque overloads.

- Backlash free torque transmission is accomplished by a series of steel balls (4) nested in hardened detents (5).
- Disc springs push against an actuation ring (3) keeping the balls nested.
- The disengagement torque is adjustable by means of an adjustment nut (1).
- In the event of an overload, the actuation ring (3) moves axially allowing the balls to come off the detents separating the drive and driven elements.
- The movement of the actuation ring (3) can be sensed by means of a mechanical switch or proximity sensor (6) triggering the drive to shut down.

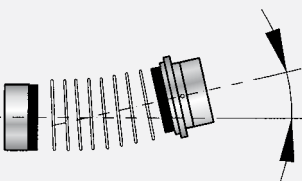
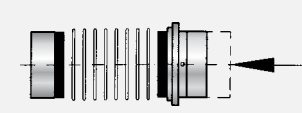
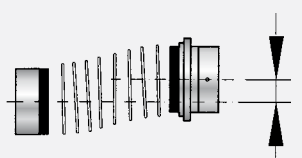
max. misalignment SK 2 - SK 5	
<p>Angular misalignment ΔK_w</p> 	<p>CAUTION: Exact alignment of the R+W Torque Limiter considerably increases the service life of the metal bellow.</p>
<p>Axial misalignment ΔK_a</p> 	<p>Reducing or eliminating lateral misalignment eliminates the radial loading of the adjacent bearings, increasing service life and reducing heat.</p>
<p>Lateral misalignment ΔK_r</p> 	<p>For drives running at high speed it is recommended to align the coupling with a dial indicator.</p> <p>Max. misalignment values see table. Axial misalignment between 1-2 mm.</p>

Single-position / Multi-position

In a torque overload, for the single-position design (standard) and multi-position design, the spring disengages to allow the balls to come out of their detents separating the drive and driven elements. Very low residual spring pressure remains so that the coupling will re-engage once the torque is reduced below the overload setting.

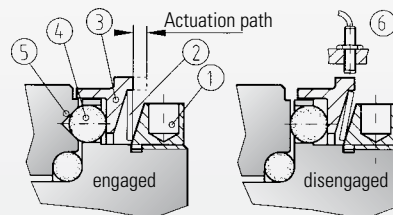

At the load holding version the drive and driven elements are only allowed limited rotation in order to achieve a movement of the actuation ring.

Re-engagement may only be effected at low speed.

Full-disengage

With this design, when a torque overload is detected, the disc spring completely flips over and places no residual spring pressure on the actuation ring. The drive and driven elements are completely separated.

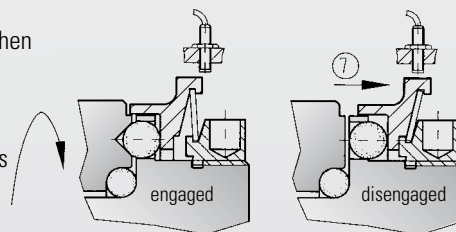

Re-engagement of the coupling is not automatic and must be performed manually (Picture 3a, 3b).

CAUTION:
Re-engagement should only be performed when the coupling is still and not rotating!

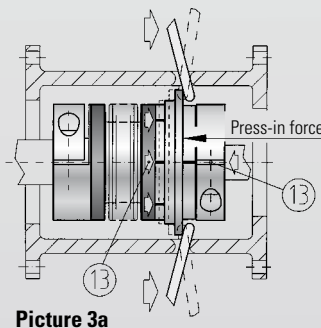

Picture 3a

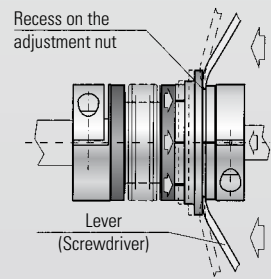

Picture 3b

The R+W full-disengage torque limiting coupling can be re-engaged in six different positions or every 60 degrees with low „press-in“ force (E). Marks on the actuation ring and body (13) of the coupling must line up and indicate the re-engagement points.

As of size 200 and up the re-engagement can be done with 2 lever which will be supported at a recess on the adjustment nut (picture 3b). Screwdrivers can be used as a lever.



MOUNTING-INSTRUCTIONS

PATENTED BACKLASH-FREE TORQUE LIMITERS FROM R+W

- All torque limiters are supplied to ISO bore tolerance grade H7. For models SK1 to SK 5 the fit tolerance of the hub/shaft connection must be between 0.01 and 0.05 mm.
- Ensure that the coupling mounts smoothly onto the shaft prior to final installation.
- Lightly oil the shaft prior to installation. Do not use sliding grease, or oils and grease with molybdenum disulfide or other high-pressure additives. Any keyways in the shaft will not affect the functioning of the clamped connection.

Model SK1/SKP

Model SK1 has an integrated bearing a for support of the attached component (for example a pulley or sprocket wheel).

Do not exceed the maximum radial force 2 (see table)

By centering the load between the dimension S, addition separate bearing support is not required.

For offset mounting, additional bearings are required.

This is recommended, for example, if the attached component has a very small diameter or the drive element has a very large width.

Depending on the installation situation, ball bearings, needle bearings or bushings may be used.

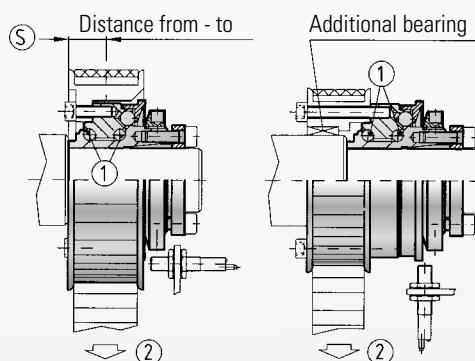

Series	1.5	2	4.5	10	15	30	60	150	200	300	500	800	1500	2500
Radial load capacity,max (N)	50	100	200	500	1400	1800	2300	3000	3500	4500	5600	8000	12000	20000
(S) from-to	3-6	5-8	6-10	6-12	7-14	8-18	8-18	12-20	12-22	12-23	12-25	14-34	20-42	32-60

Disengagement torque setting

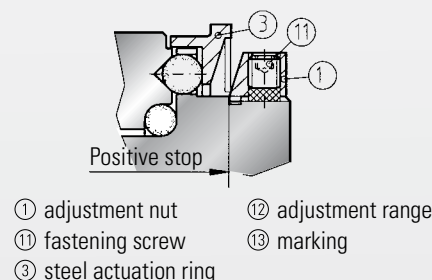
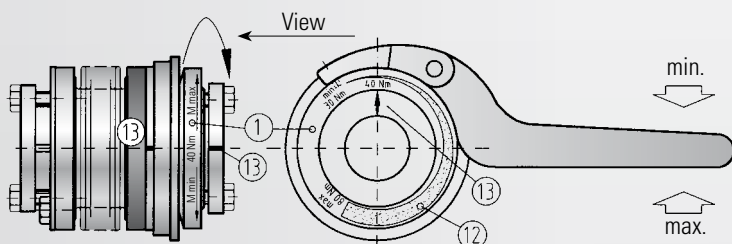

- ① adjustment nut
- ⑪ fastening screw
- ③ steel actuation ring
- ⑫ adjustment range
- ⑬ marking

R+W torque limiters are factory set to the customer specified disengagement torque, which is marked onto the coupling. The adjustment range (min/max) is also marked on the adjustment nut (1). The customer can adjust the disengagement torque as long as it falls into the range (12) indicated on the adjustment nut.

The adjustment range may not be left during setting.

To adjust the disengagement torque, loosen the locking screws (11) and rotate the adjustment ring using a spanner wrench to the desired new setting. Tighten the 3 locking screws (11) and test the coupling.

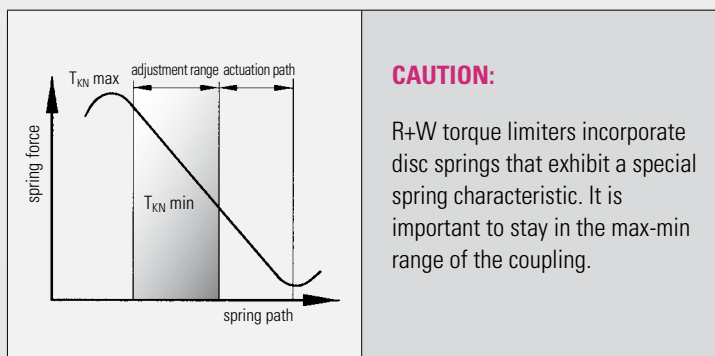

CAUTION:

R+W torque limiters incorporate disc springs that exhibit a special spring characteristic. It is important to stay in the max-min range of the coupling.

MOUNTING AND DISMOUNTING: SK MODELS

SKP with key way

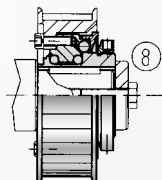

Mounting:
Slide the coupling onto the shaft. Lock it in position, with an endplate (8) for example.

Dismounting:
Remove the end plate and slide the coupling off the shaft using an appropriate tool.

SK 1 with clamping hub Series 1.5 - 10

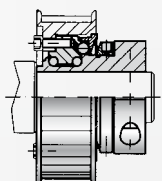

Mounting:
Slide the coupling onto the shaft to the proper axial position. Using a torque wrench tighten the clamp screw to the proper tightening torque as indicated. (see page 7)

Dismounting:
Simply loosen the clamp screw and remove the coupling.

SK 1 with tapered bushing

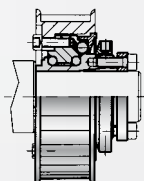

Mounting:
Slide the coupling onto the shaft to the proper axial position. Using a torque wrench, uniformly tighten the clamping screws using a cross-wise tightening pattern. Apply 1/3, 2/3 and full torque until all the clamping screws are evenly tightened to the correct tightening torque as given on page 6.

CAUTION: Further tightening of the clamping screws may destroy the tapered bushing connection. While tightening the coupling may move slightly towards the tapered bushing.

Dismounting:
Loosen the clamping screw. Insert the three jack screws into the taped holes on the tapered segment apply even pressure to remove the tapered segment. Remove the coupling.

SK 2 with clamping hub

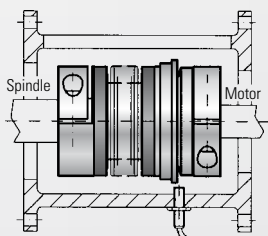

Mounting:
Prior to mounting make sure that the shaft to be connected does not exceed the angular or lateral misalignment limits for the coupling size to be used. This data can be found in the catalog. Slide the coupling on the first shaft end to the proper axial position. Using a torque wrench, tighten the clamp screw to the correct tightening torque as indicated (page 8). Insert the second shaft into the other end of the coupling to the proper axial position. Make sure that the coupling is free of any axial forces before tightening. Tighten the clamp screw as above using a torque wrench.

Dismounting:
Simply loosen the clamp screw and remove the coupling.

SK 3 with tapered bushing

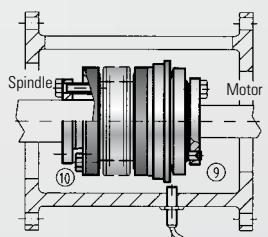

Mounting:
Prior to mounting make sure that the shaft to be connected does not exceed the angular or lateral misalignment limits for the coupling size to be used. This data can be found in the catalog. Slide the coupling onto the first shaft to the proper axial position. Using a torque wrench, uniformly tighten the clamping screws using a cross-wise tightening pattern. Apply 1/3, 2/3 and full torque until all the clamping screws are evenly tightened to the correct tightening torque (see page 9).

CAUTION: Mounting is completed. Further tightening of the clamp screws may destroy the tapered bushing connection.

Dismounting:
Loosen the clamping screws. Use the three jackscrews 9 conveniently mounted in the taper segment and 10 on the bellow body to evenly back out the tapered segment. Remove the coupling.

SK 5 with press-fit tapered clamping hubs

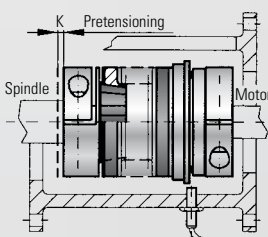

Mounting:
Prior to mounting it is necessary to consider the overall length of the assembled coupling. The press-fit coupling requires a specific pre-tensioning (K) between the two coupling halves to ensure backlash free operation. Mount the „female“ coupling half containing the bellow onto the first shaft end to the proper axial position. Using a torque wrench tighten the clamp screw to the proper tightening torque. Mount the „male“ coupling segment onto the second shaft end. The proper axial position is when the two couplings come together and coupling is compressed by the proper pre-tension distance (K). See page 10. When the coupling segment is properly positioned tighten the clamp screw to the proper torque.

Dismounting:
Pull the coupling apart. Simply loosen the clamp screws and remove the coupling from the shaft.



ADDITIONAL INFORMATION

PATENTED BACKLASH-FREE TORQUE LIMITERS FROM R+W

Behaviour and characteristic

Disengagement behavior

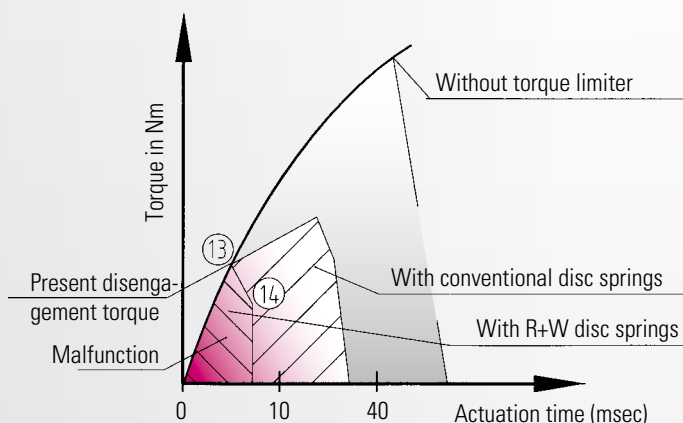

Spring characteristic

Degrassive spring characteristic

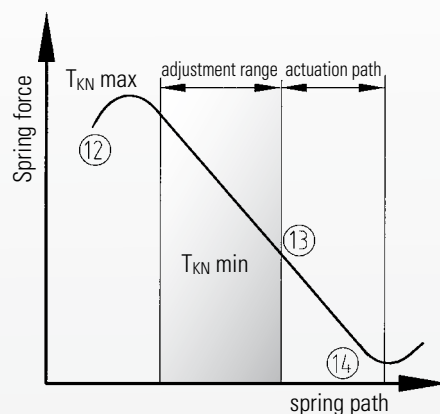

Spring package:

R + W torque limiters function by means of a disc spring with a digressive characteristic developed exclusively for this application. Upon the couplings actuation, this characteristic (13) brings about an immediate drop in the torque (14) and an interruption of the force flux.

The spring force of the disc spring drops to a lower value after the disengagement process.

This advantage guarantees extremely short actuation times (1-3 ms), low wear and very low residual friction (between 2-5 %).

Speed:

The service life of the coupling is essentially determined by the number of rotations after disengagement.

Wear:

No wear occurs during engaged operating condition. In the event of an overload the drive should be stopped through a mechanical limit switch or proximity switch immediately.

Maintenance:

When properly engaged, the torque limiters are wear free, and therefore require no maintenance. The ball detent mechanism within each coupling is permanently lubricated.

Seal:

Optional sealing of the coupling is possible:

Advantages of the sealing:

- Protection from dirt and liquid contamination
- Appropriate for food service and light washdown environments
- No escape of grease possible

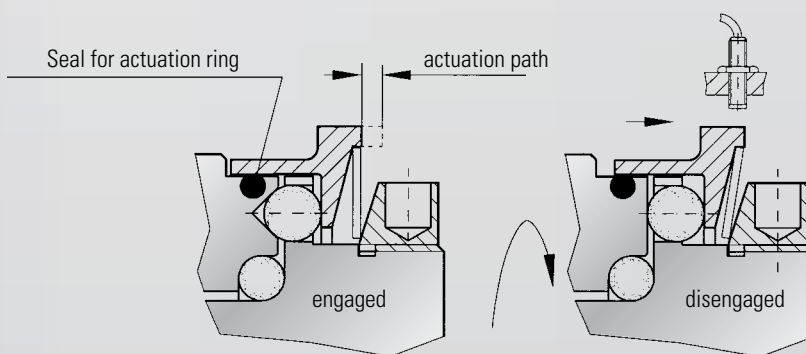

Prior technical approval is suggested, for applications using our products other than specified.

SELECTION

According to disengagement torque

As a rule torque limiters are rated according to the required disengagement torque, which must be greater than the torque that is necessary for regular machine operation.

$$T_{KN} \geq 1.5 \cdot T_{AS} \text{ (Nm)}$$

T_{KN} = rated torque of coupling (Nm)
 T_{AS} = peak torque of motor (Nm)

The disengagement torque of the torque limiters is determined as a rule in accordance with the drive specifications.

or

$$T_{KN} \geq 9550 \cdot \frac{P_{AN}}{n} \cdot 1.5 \text{ (Nm)}$$

T_{KN} = rated torque of coupling (Nm)
 P_{AN} = drive power (kw)
 n = speed of drive (rpm)

The following calculation has proven itself as a rule of thumb solution:

According to acceleration torque (start-up at no load)

S_A = jerk or load factor

$S_A = 1$ (uniform load)
 $S_A = 2$ (non-uniform load)
 $S_A = 3$ (jerky load)

$$T_{KN} \geq \alpha \cdot J_L \geq \frac{J_L}{J_A + J_L} \cdot T_{AS} \cdot S_A \text{ (Nm)}$$

T_{KN} = rated torque of coupling (Nm)
 α = angular acceleration $\frac{1}{s^2}$
 $\alpha = \frac{\omega}{t} = \frac{\pi \cdot n}{t \cdot 30}$

Values for $S_A = 2-3$ are usual for servo drives on machine-tools

t = acceleration time (s)
 ω = angular speed in (s⁻¹)
 n = speed of drive (rpm)
 J_L = moment of inertia on load side (kgm²)
 J_A = moment of inertia on driving side (kgm²)
 T_{AS} = peak torque of motor (Nm)

According to acceleration and load torque (start with load)

$$T_{KN} \geq \alpha \cdot J_L + T_{AN} \geq \left[\frac{J_L}{J_A + J_L} \cdot (T_{AS} - T_{AN}) + T_{AN} \right] \cdot S_A \text{ (Nm)}$$

S_A = jerk or load factor

$S_A = 1$ (uniform load)
 $S_A = 2$ (non-uniform load)
 $S_A = 3$ (jerky load)

Values for $S_A = 2-3$ are usual for servo drives on machine-tools

T_{KN} = rated torque of coupling (Nm)
 α = angular acceleration $\frac{1}{s^2}$
 $\alpha = \frac{\omega}{t} = \frac{\pi \cdot n}{t \cdot 30}$

t = acceleration time (s)
 ω = angular speed in (s⁻¹)
 n = speed of drive (rpm)
 J_L = moment of inertia on load side (kgm²)
 T_{AN} = load torque (Nm)
 J_A = moment of inertia on driving side (kgm²)
 T_{AS} = peak torque of motor (Nm)



SELECTION

PATENTED BACKLASH-FREE TORQUE LIMITERS FROM R+W

According to feed force

Spindle drive

$$T_{AN} = \frac{s \cdot F_V}{2000 \cdot \pi \cdot \eta} \text{ (Nm)}$$

- T_{AN} = load torque (Nm)
- S = spindle pitch (mm)
- F_V = feed force (N)
- η = spindle efficiency

Timing belt drive

$$T_{AN} = \frac{d_0 \cdot F_V}{2000} \text{ (Nm)}$$

- T_{AN} = load torque (Nm)
- d_0 = pinion dia. (pulley) (mm)
- F_V = feed force (N)

According to resonant frequency (SK 2 / 3 / 5 with bellows attachment)

Usually high resonant frequencies of the couplings are required in order to make high acceleration values possible and avoid any vibration excitation.

For the purpose of calculation the drive is reduced to a 2 mass system.

$$f_e = \frac{1}{2 \cdot \pi} \sqrt{C_T \times \frac{J_{Masch} + J_{Mot}}{J_{Masch} \cdot J_{Mot}}} \text{ (Hz)}$$

- C_T = torsional stiffness of the coupling (Nm/rad)
- $J_{Masch.}$ = moment of inertia of machine (spindle + slide + workpiece + half of coupling) (kgm²)
- $J_{Mot.}$ = moment of inertia of motor (motor's rotor + half of coupling) (kgm²)
- f_e = Resonant frequency of a two mass system (Hz)

According to torsional stiffness (SK 2 / 3 / 5 with bellows attachment)

Transmission errors due to a torsional stress on the metal bellows:

$$\varphi = \frac{180}{\pi} \cdot \frac{T_{AS}}{C_T} \text{ (Degrees)}$$

- φ = angle of turn (degrees)
- C_T = torsional stiffness of coupling (Nm/rad)
- T_{AS} = peak torque of motor (Nm)

According to the function system

Load holding version: On SK1 / SKP models the load holding version has a double load safety margin. Ensure that models with bellows (SK2, 3 and 5) are of adequate size. The blocking load in this case should not exceed the nominal torque of the coupling.

R+W: QUALITY AND KNOW-HOW

Quality and know-how for couplings in servo, NC and stepper motor systems.

The demands on drive technology have dramatically and steadily increased in the last few years. Our company **R+W** is proud to have reached a leading market position within the same few short years and we continue to work hard in the areas of design and technical development to stay there. **R+W** has representatives in more than 40 countries all over the world and is opening more branches every year.

Our range of high-quality precision couplings meet the needs of the most demanding applications. But for our technical staff this is not enough. We are constantly developing, new solutions, new designs, new possibilities.

We want you to contact us, to give us the opportunity to create a solution and to earn your business. Each person on the **R+W** staff knows that quality comes from his or her personal engagement with, and listening to, the customer.

Benefit from our quality and efficiency.

We are ISO 9001 certified. Our production and customer service department have been organized to maximize efficiency and minimize delivery time.

Extensive quantities of component inventory are kept on hand to ensure the quickest possible delivery, often within one day. Special designs are a major part of our business and are immediately processed, designed and built. **R+W** also has developed proprietary software to calculate resonant frequencies and aid.

R+W continues to reinvest to ensure that our couplings remain innovative to improve their efficiency and operating dependability with your applications.



Special low cost rust protection process

Corrosion protection which is equivalent to that of galvanized or chrome-plated surfaces is available.

The positive features of this include good resistance to wear and corrosion.

The parts are resistant to a salt spray test pursuant to DIN 50021 for a period of 140 hours.

This process represents a genuine, low cost alternative to expensive stainless steel materials.

Couplings with this surface treatment have been used for many years by well-known companies in the food industry.



Versions in explosion-proof design

All models can be supplied in an explosion-proof design to order without any change in dimensions.



DXF + 3D files

The complete product range can be supplied on CD-ROM in DXF and DWG files. This allows the files to be imported into design programs easily. 3 dimensional drawings of the couplings are also available.



Download

All the drawings can be downloaded directly from our homepage www.rwcouplings.com.



DIN ISO 9001

Quality awareness is a high priority at R+W.

The introduction of DIN ISO 9001 has meant the refinement of quality procedures and the appropriate documentation.

In a one-year preparation period, the ISO 9001 quality system was produced and certified on 4 March 1997.

Constant monitoring and improvement of the system ensures a technically superior product with a quality standard second to none.





**Experience and
Know-how
for your special
requirements.**

R+W Antriebselemente GmbH
Alexander-Wiegand-Straße 8
D-63911 Klingenberg/Germany

Tel. +49-(0)9372 – 9864-0
Fax +49-(0)9372 – 9864-20

info@rw-kupplungen.de
www.rwcouplings.com



TGA-ZM-05-91-00
Registration No. 9605022

The information mentioned in this document is based on our present knowledge and experiences and does not exclude the manufacturer's own substantial testing of the equipment. So this is no obligatory assurance even with regard to protection rights of Third Parties. The sale of our products is subject to our General Conditions of Sale and Delivery.



**TORQUE LIMITERS
Series SK**

From 0,1 – 2.800 Nm, Bore diameters 4 – 70 mm
Available as a single position, multi-position, load holding, or full disengagement version
Single piece or press-fit design



**BELLOW COUPLINGS
Series BK**

From 15 – 10.000 Nm
Bore diameters 10 – 180 mm
Single piece or press-fit design



**BELLOW COUPLINGS
ECONOMY CLASS
Series BKL / BKC**

From 2 – 500 Nm
Bore diameters 4 – 62 mm



**LINE SHAFTS
Series ZA/ZE**

From 10 – 4.000 Nm
Bore diameters 10 – 100 mm
Available up to 6 mtr. length



**MINIATURE BELLOWS COUPLINGS
Series MK**

From 0,05 – 10 Nm
Bore diameters 1 – 28 mm
Single piece or press-fit design



**SERVOMAX®
ELASTOMER COUPLINGS
Series EK**

From 5 – 2.000 Nm, Shaft diameters 5 – 80 mm
backlash-free, press-fit design



**LINEAR COUPLINGS
Series LK**

From 70 – 2.000 N
Thread M5 – M16



**POLYAMID COUPLINGS
MICROFLEX
Series FK 1**

Rated torque 1 Ncm
Bore diameters 1 – 1,5 mm