



# SNL 30 and SNL 31 plummer block housings solve the housing problems

(Replace SD housing range)

**Only for review!  
Printing not allowed.**



# Contents

**Made by SKF®** stands for excellence. It symbolises our consistent endeavour to achieve total quality in everything we do. For those who use our products, “Made by SKF” implies three main benefits.

**Reliability** – thanks to modern, efficient products, based on our worldwide application know-how, optimised materials, forward-looking designs and the most advanced production techniques.

**Cost effectiveness** – resulting from the favourable ratio between our product quality plus service facilities, and the purchase price of the product.

**Market lead** – which you can achieve by taking advantage of our products and services. Increased operating time and reduced down-time, as well as improved output and product quality are the key to a successful partnership.



## 1 Product information..... 3

|  |
|--|
| <b>Fewer bearing replacements and less maintenance... 3</b>        |
| Plummer block housings have much to offer..... 3                   |
| SNL 30 and SNL 31 plummer block housings have more to offer..... 3 |
| One basic design – many variants..... 4                            |
| Costs and risks – at a low level ..... 6                           |
| High performance for all sectors..... 8                            |

## 2 Recommendations..... 10

|  |
|--|
| <b>Bearing arrangement design ..... 10</b>                       |
| Bearings on adapter sleeves on smooth shafts..... 10             |
| Bearings on cylindrical seatings on stepped shafts ..... 11      |
| Standard seals..... 12   |
| Special seals..... 15  |
| End covers..... 17   |
| Locating rings ..... 17  |
| <b>Application advice for trouble-free operation..... 18</b>     |
| Lubrication ..... 20   |
| Mounting ..... 22  |
| Mounting SNL 30 and SNL 31 housings with labyrinth seals..... 24 |
| Mounting SNL 30 and SNL 31 housings with taconite seals..... 26  |
| Mounting SNL 30 and SNL 31 housings with oil seals..... 28       |

## 3 Product data ..... 30

|  |
|--|
| <b>Designations and housing data ..... 30</b>                                |
| Designations ..... 30  |
| Load carrying ability..... 31  |
| <b>Product tables..... 34</b>  |
| Large SNL plummer block housings for bearings on adapter sleeve ..... 34     |
| Large SNL plummer block housings for bearings with cylindrical bore ..... 42 |

## Other products for trouble-free operation..... 48

## The SKF Group – a worldwide corporation..... 52

# Fewer bearing replacements and less maintenance

## Plummer block housings have much to offer

The main benefit of split plummer block housings is their easy installation; pre-assembled shafts can be mounted in them. When the housing bases are attached to the base plate it is then only necessary to place the housing caps in position and to tighten the attachment bolts to complete the installation.

Split plummer block housings available on the market are mainly intended for self-aligning ball bearings, spherical roller bearings and CARB® bearings of ISO Dimension Series 02, 03, 22, 23, 30, 31, 32, 39, 40 and 41. They can often be fitted with various different seals. Many designs and variants of split plummer block housings are available making the use of tailored housings unnecessary and thus enabling cost effective bearing arrangements to be made.

For many years SKF has been one of the leading suppliers of various designs of split plummer block housings, including the SD plummer block housings – synonymous with operational reliability and quality.

## SNL 30 and SNL 31 plummer block housings have more to offer

SKF plummer block housings of the SD design are currently being redesigned to take advantage of the progress embodied in the smaller SNL housings. The new plummer block housings of series SNL 30 and SNL 31 will gradually replace the SD housings and are also referred to as “Large SNL plummer block housings”.

The new SNL plummer block housings enable the full service life potential of the incorporated bearings to be exploited with less need of maintenance. This supports user efforts to further reduce maintenance costs. Among other enhancements the SNL housings have a new external design for easier alignment and handling when mounting.

Another benefit is the choice of oil or grease lubrication for the bearings housed in SNL plummer blocks. A range of newly developed seals for oil lubrication and rough environments make for trouble-free operation.



## One basic design – many variants

Large SNL plummer block housings are primarily intended for spherical roller bearings and CARB bearings. The housings are designed on a “building block” principle. This enables a more generous choice of bearing, shaft mounting, seals and type of lubrication.

### A building block system

The basis of the original SNL plummer block housing system consists of a number of housings of the same design but in different sizes. By combining the housings with the different standard seals a wide variety of housing variants, all belonging to the standard range, can be supplied to cover the majority of demands for plummer blocks.

When complete the new range of series SNL 30 and SNL 31 will be available for shafts having diameters of 150 to 500 mm, inclusive. However, initially the range extends to shaft sizes up to 300 mm; the larger sizes will gradually become available as design work is completed. The availability of housings for which only shaft size and designations are given in the product tables should be checked before ordering.

The standard range will also cover housings with drilled and tapped holes for lubrication nipples. There are variants to be drilled upon request for condition monitoring.

Series SNL 30 and SNL 31 plummer block housings are made of grey cast iron and demonstrate the same high strength as the earlier SD housings. Should, however, this strength be inadequate, dimensionally equivalent SNLD plummer block housings of spheroidal graphite cast iron are available.

### Several sealing options

An important advantage of the SNL plummer block housings is that they can be fitted with different seals. The standard seals supplied by SKF for the large SNL 30 and SNL 31 series housings comprise labyrinth seals and heavy-duty “taconite” seals as well as end covers. There is also an oil seal available but this sealing arrangement is supplied together with the housing as the housing has to be modified to take it.

These large SNL plummer block housings are fully interchangeable with the earlier SD housings. Their dimensions conform to ISO 113:1999.

*Large SNL plummer block housing with sealing options*



## Costs and risks – at a low level

The new SNL 30 and SNL 31 plumber block housings represent a further development of the SD housings. These large SNL housings have several special features as well as sealing alternatives.

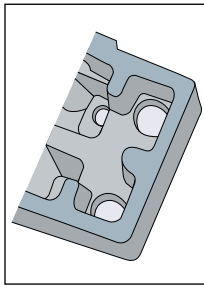

### Reinforced square base

The housing base is reinforced with walls around the holes for the attachment bolts in order to provide improved seating on the base plate. The attachment bolts can be preloaded to give better location and can no longer deform the housing base or housing bore.

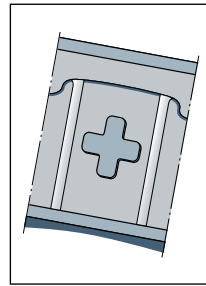

### Enlarged contact area

The centre cross reinforcement of the housing base enlarges the contact area between base and base plate and allows for an improved heat flow from the bearing outer ring to the base plate.

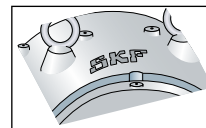

### Drilled and tapped holes

Housings have drilled and tapped holes as standard in the cap. The holes are protected by metallic plugs. Two nipples are supplied, together with nipple protector and adapter, with the housing (packed inside). If the application is such that relubrication is required it is only necessary to screw the nipples into the holes and lubricant can be supplied to one side of the bearing or in the W33 groove. There are also indications on the housing where holes can be drilled for lubrication of the seals.

|  |   |
|--|---|
| ● Reinforced square base                         | Easy to align   |
| ● Enlarged contact area                          | Reinforced housing base and improved heat flow  |
| ● Drilled and tapped holes with nipples          | Relubrication facility as standard  |
| ● Caps and bases individually marked             | Avoids mixing of caps and bases, permits traceability   |
| ● Indications for holes to take other components | Simple and easy adaptation of standard housing to individual application, easy attachment of condition monitoring equipment |
| ● Simple and reliable                            | Simpler and more reliable mounting and maintenance  |
| ● Additional seals                               | Extended range of use, longer bearing service lives   |

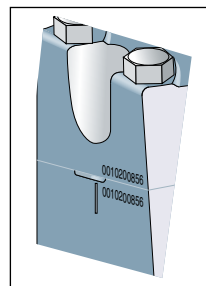

### Caps and bases individually marked

The housing base and cap are matched during manufacture and are not interchangeable with the caps and bases of other housings. To prevent mixing caps and bases when mounting several housings, the same consecutive number is marked on the cap and base of each individual housing.

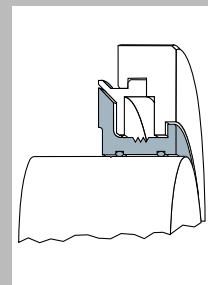
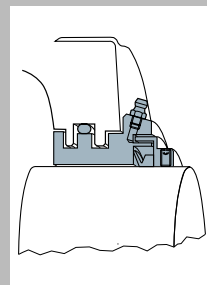
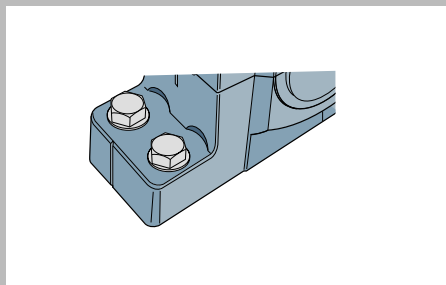
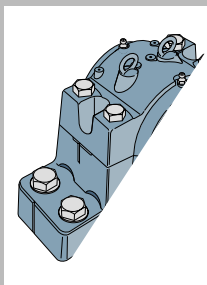

**Indications for holes to take other components**

SNL housings can be fitted with sensors serving permanently installed condition monitoring equipment based on vibration measurements. The positions where holes can be drilled to take these sensors are indicated on the housing.

**Simpler and safer**

In order to simplify mounting and make alignment more accurate, cast indications, which are vertical to the centre of the bore of the housing, are provided on the side faces of the housing base. Cast indications on the end faces of the base show the centre of the bearing.

**Additional seals**

Two new seal designs have been developed specifically for SNL housings. One is intended for difficult conditions that call for a robust seal which can be relubricated and the other is for high speeds and oil lubrication.

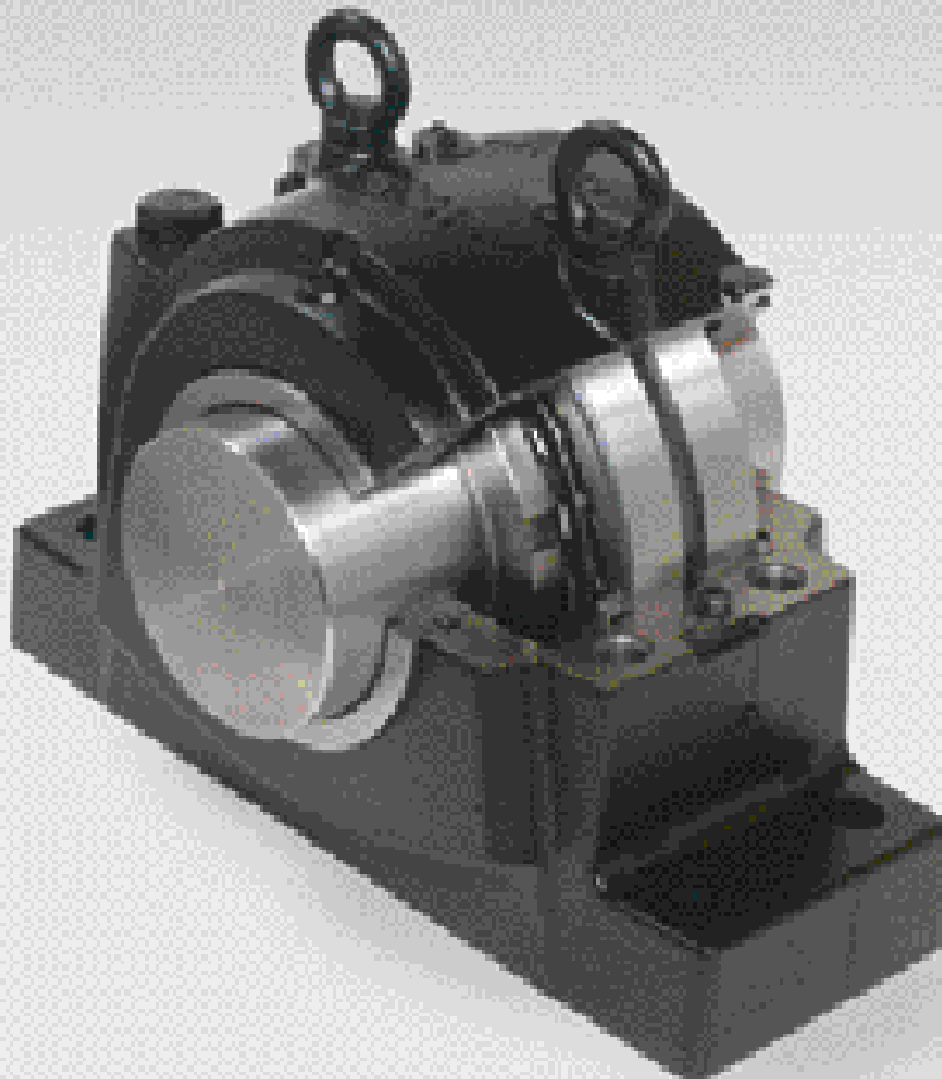

## High performance for all sectors

High load carrying capacity and reliability, easy maintenance, the variety of applications and robust designs have made SKF housings a must. The most important sectors of industry and their demands are listed below.

One important reason for the popularity of SKF housings is the increased awareness of the impact of enhanced quality on the cost of a machine and its total life.

### Industry

- Materials handling
- Handling systems
- Mining and construction
- Fluid machinery
- Metallurgical
- Pulp and paper

### Demands

- Long service life
- Robust design
- Long relubrication intervals
- Ready for relubrication
- Condition monitoring facilities
- Avoid risk of mixed caps
- Fast and easy mounting and dismounting

### Solution





1



# Bearing arrangement design

Large SNL plummer block housings of series SNL 30 and SNL 31 can be used with spherical roller bearings or CARB bearings fitted on smooth (plain) or stepped shafts; the bearings can be mounted on adapter sleeves or directly on cylindrical shaft seatings.

## 1. Bearings on adapter sleeves on smooth shafts

### Advantages

- Drawn round bar (tolerance h9) can be used without machining
- Maximum shaft strength as there is no weakening by shoulders or reliefs
- Bearings can be mounted at any position on the shaft
- Mounting force, i.e. the force required to drive up the bearing on to the sleeve, is some 40 % smaller than with other bearing arrangements on sleeves because friction occurs only in one contact

- Bearing radial clearance can be adjusted within certain limits during mounting to meet application demands

### Applications

- Bearing arrangements for relatively long shafts where more than two bearings are required for support
- Bearing arrangements where machine components are mounted using wedging or tensioning components which do not require the shaft to be machined
- Bearing arrangements where the final position of the bearing cannot be accurately determined

*Bearings on adapter sleeves on smooth shafts*

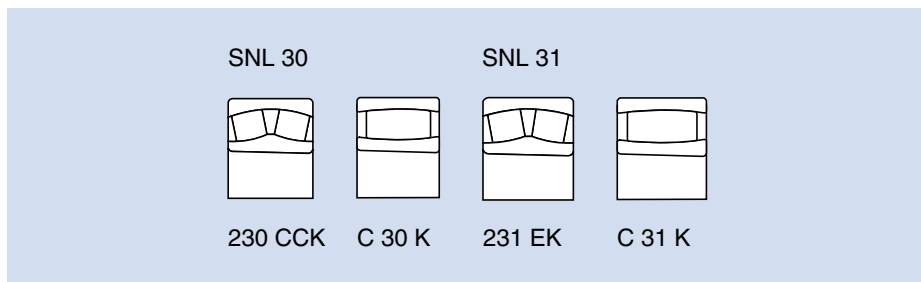
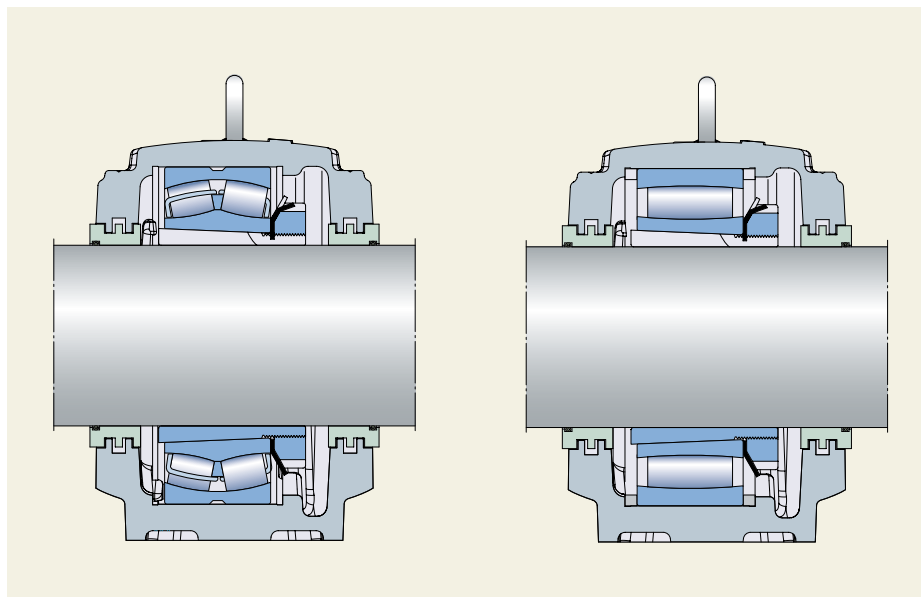

## 2. Bearings on cylindrical seatings on stepped shafts

### Advantages

- The axial load carrying capacity of the bearings (in both directions) is not limited by a sleeve
- The residual bearing internal clearance is determined by the tolerance of the shaft seating so there is no danger of radially preloading the bearing during mounting
- The bearing position on the shaft is accurately determined by the shaft shoulder
- The bearing can be supported by other components via spacer sleeves
- The shaft diameter at the bearing position is maximised

### Applications

- Bearing arrangements where large numbers of bearings have to be mounted
- Bearing arrangements where heavy shock loads can occur

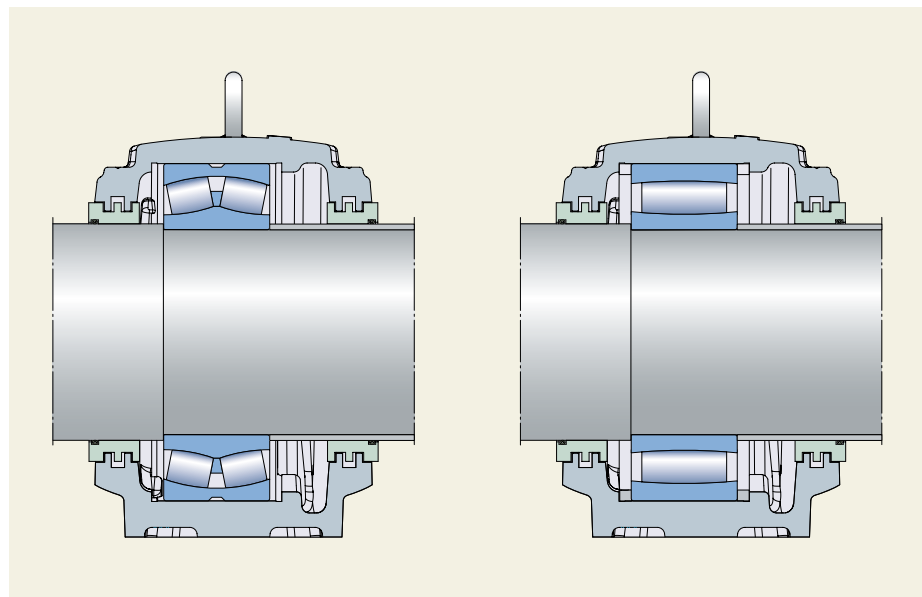

*Bearings on cylindrical seatings on stepped shafts*

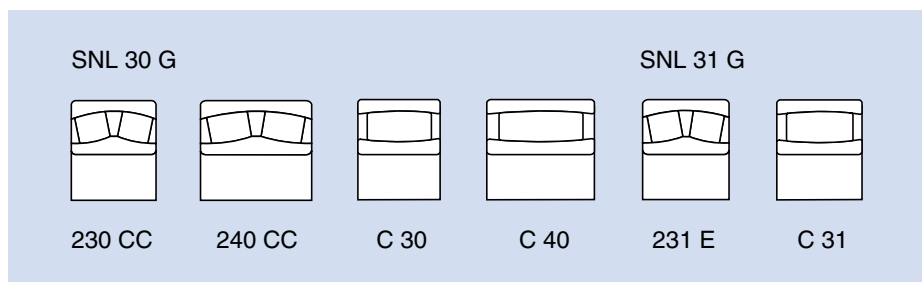

## Standard seals

The standard seals available from SKF for large SNL housings (series SNL 30 and SNL 31) are one-piece labyrinth seals and the heavy-duty “taconite” seals. The seals are easy to install and are supplied separately.

The standard seals as well as the seals for use with oil lubrication are

presented in **Table 1**, which gives a comprehensive overview of the seal types, their design features and their suitability for various operating conditions. Detailed information on the various standard and special seals including properties and availability will be found on **pages 13 to 15**.

### Seal selection

**Table 1**

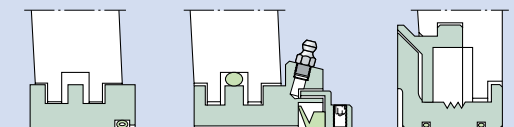

TS ..

TNF ..

TSD .. U<sup>1)</sup>

| Properties                      | TS ..  | TNF ..      | TSD .. U <sup>1)</sup> |
|---------------------------------|--|-------------|------------------------|
| Temperature, °C                 | -50 to +200  | -40 to +100 | -50 to +200            |
| Peripheral speed, m/s           | ++   | ≤ 12        | ++                     |
| Misalignment, degrees           | ≤ 0,3  | ≤ 0,3       | ≤ 0,3                  |
| Grease relubrication            | +  | +           | -                      |
| Oil lubrication                 | -  | -           | ++                     |
| Low friction                    | ++   | +           | ++                     |
| Axial shaft displacement        | +  | +           | -                      |
| Vertical arrangement            | --   | -           | --                     |
| <b>Sealing ability against</b>  |  |             |                        |
| Dust                            | +  | ++          | +                      |
| Fine particulate contaminants   | +  | ++          | +                      |
| Coarse particulate contaminants | +  | ++          | +                      |
| Abrasive contaminants           | ++   | ++          | ++                     |
| Liquids when sprayed            | --   | ++          | -                      |
| Direct sunlight                 | ++   | ++          | ++                     |
| Symbols:                        | ++ very suitable<br>+ suitable<br>- limited suitability<br>-- unsuitable |             |                        |

<sup>1)</sup> The oil seals are supplied together with housings prepared for oil lubrication. Oil seals can be ordered separately as spares only

**Labyrinth seals**

The labyrinth rings (→ fig 1) are made of cast iron and have three radially arranged labyrinth steps which form a narrow sealing gap with the housing grooves.

Hollow O-ring cords of silicone rubber (supplied with the seals) ensure that the labyrinth rings, which are mounted with a loose fit, rotate with the shaft. Angular misalignments of the shaft up to approximately 0,3° are permissible. The operating temperature range for the labyrinth seals is -50 to +200 °C.

When labyrinth seals are used, axial movement of the shaft relative to the housing is not limited.

The labyrinth seals are supplied singly. For bearing arrangements for through shafts it is therefore necessary to order two rings. The labyrinth seal is identified by the prefix TS followed by the size identification, e.g. TS 34.

**Taconite heavy-duty seals**

Taconite is a very fine-grained mineral which is extremely difficult to seal against. For bearing arrangements which must operate under very arduous conditions such as those encountered in mining, labyrinth seals which can be relubricated are recommended, as grease enhances the sealing effect and extends the serviceability of the seals. SKF has developed a heavy-duty seal (which can seal against taconite, hence the name) which can be supplied for use with SNL housings.

The taconite seal design (→ fig 2) is based on a labyrinth seal with the labyrinth stages arranged axially and fits the standard housings. A V-ring seal mounted on the shaft seals against the non-rotating part of the seal, which is inserted in the seal groove and prevents contaminants from penetrating to the bearing when the seal is relubricated. This grease is supplied via a

grease nipple on the non-rotating part of the seal. Angular misalignments of the shaft of up to approximately 0,3° are possible.

The permissible operating temperature range for the seal is between -40 and +100 °C. Please contact SKF for applications above 100 °C. The rubber O-ring and V-ring limit the operating temperature to 100 °C. However, SKF can supply high temperature O-rings and V-rings made of fluoro rubber for operation at higher temperatures.

The axial movement of the shaft relative to the housing is limited for this type of taconite seal to approximately ±2 mm for sizes from 150 up to 200 mm and ±4 mm for larger shaft diameters.

These seals are supplied singly so that for housings used on through shafts, it is necessary to order two seals. The seal is identified by the prefix TNF followed by the size identification, e.g. TNF 34.

**Seals for oil lubrication**

**Labyrinth seal**

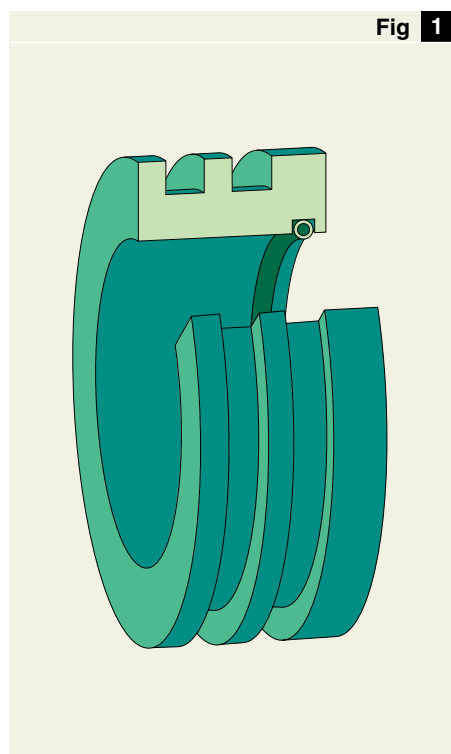

**Taconite heavy-duty seal**

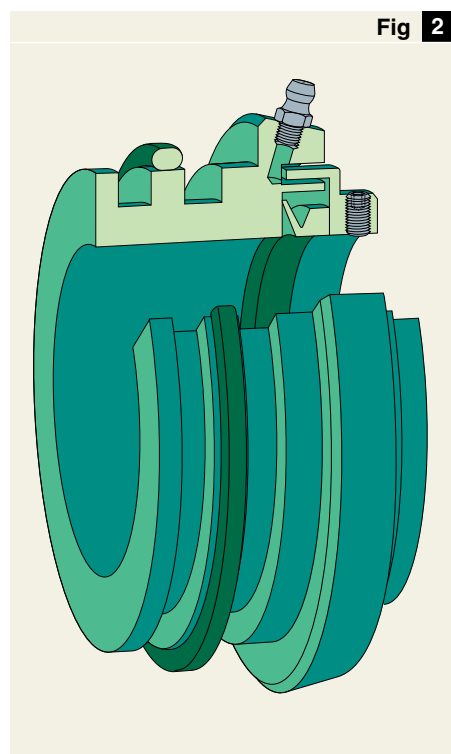

Special seals (oil seals) are required to prevent oil from escaping from the housing when oil lubrication is applied. For SNL housings, SKF has developed the non-rubbing seal of the U design (→ fig 3). These U seals also require modified housings and comprise two parts: one which is stationary and fitted in the modified seal groove and the other which is mounted on the shaft and rotates. The hollow O-ring cords of silicone rubber inserted between the labyrinth ring and the shaft ensure that the ring, which is mounted with a loose fit, rotates with the shaft, and oil cannot escape along the shaft. These oil seals do not limit axial movement of the shaft relative the housing.

The modified SNL housing is supplied together with the seals as a unit. The housings with seals are identified by the suffix TURT (TURA for CARB bearings) e.g. SNL 3134 TURT. The seal itself is designated TSD .. U.

Oil seal

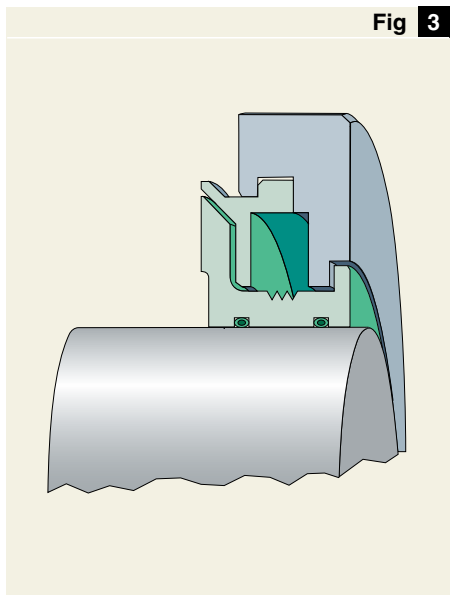

Table 2

| Housing Size      | Dimensions     |                |                |                |                |                |                |
|-------------------|----------------|----------------|----------------|----------------|----------------|----------------|----------------|
|                   | A <sub>3</sub> | A <sub>4</sub> | A <sub>5</sub> | A <sub>6</sub> | D <sub>b</sub> | D <sub>c</sub> | D <sub>d</sub> |
| –                 | mm             |                |                |                |                |                |                |
| <b>SNL 3036</b>   | 158            | 11             | 5,5            | 22             | 181,2          | 196,4          | 205,2          |
| <b>SNL 3038</b>   | 168            | 11             | 5,5            | 22             | 191,4          | 206,4          | 215,4          |
| <b>SNL 3040</b>   | 186            | 11             | 5,5            | 22             | 201,4          | 216,4          | 225,4          |
| <b>SNL 3044</b>   | 206            | 11             | 5,5            | 22             | 221,4          | 236,4          | 245,4          |
| <b>SNL 3048</b>   | 214            | 11             | 5,5            | 22             | 241,4          | 256,4          | 265,4          |
| <b>SNL 3052</b>   | 231            | 11             | 5,5            | 22             | 261,6          | 276,6          | 285,6          |
| <b>SNL 3056</b>   | 249            | 11             | 5,5            | 22             | 281,6          | 296,6          | 305,6          |
| <b>SNL 3060</b>   | 249            | 11             | 5,5            | 22             | 301,6          | 316,6          | 325,6          |
| <b>SNL 3064</b>   | 279            | 11             | 5,5            | 22             | 321,8          | 336,8          | 345,8          |
| <b>SNL 3068</b>   | 299            | 11             | 5,5            | 22             | 341,8          | 356,8          | 365,8          |
| <b>SNL 3072</b>   | 297            | 11             | 5,5            | 22             | 361,8          | 376,8          | 385,8          |
| <b>SNL 3076</b>   |                |                |                |                |                |                |                |
| <b>SNL 3080</b>   |                |                |                |                |                |                |                |
| <b>SNL 3084</b>   |                |                |                |                |                |                |                |
| <b>SNL 3088</b>   |                |                |                |                |                |                |                |
| <b>SNL 3092</b>   |                |                |                |                |                |                |                |
| <b>SNL 3096</b>   |                |                |                |                |                |                |                |
| <b>SNL 30/500</b> |                |                |                |                |                |                |                |
| <b>SNL 3134</b>   | 159            | 11             | 5,5            | 22             | 171,2          | 186,4          | 195,2          |
| <b>SNL 3136</b>   | 169            | 11             | 5,5            | 22             | 181,2          | 196,4          | 205,2          |
| <b>SNL 3138</b>   | 187            | 11             | 5,5            | 22             | 191,4          | 206,4          | 215,4          |
| <b>SNL 3140</b>   | 207            | 11             | 5,5            | 22             | 201,4          | 216,4          | 225,4          |
| <b>SNL 3144</b>   | 215            | 11             | 5,5            | 22             | 221,4          | 236,4          | 245,4          |
| <b>SNL 3148</b>   | 231            | 11             | 5,5            | 22             | 241,4          | 256,4          | 265,4          |
| <b>SNL 3152</b>   | 249            | 11             | 5,5            | 22             | 261,6          | 276,6          | 285,6          |
| <b>SNL 3156</b>   | 249            | 11             | 5,5            | 22             | 281,6          | 296,6          | 305,6          |
| <b>SNL 3160</b>   | 280            | 11             | 5,5            | 22             | 301,6          | 316,8          | 325,6          |
| <b>SNL 3164</b>   | 300            | 11             | 5,5            | 22             | 321,8          | 336,8          | 345,8          |
| <b>SNL 3168</b>   |                |                |                |                |                |                |                |
| <b>SNL 3172</b>   |                |                |                |                |                |                |                |
| <b>SNL 3176</b>   |                |                |                |                |                |                |                |
| <b>SNL 3180</b>   |                |                |                |                |                |                |                |
| <b>SNL 3184</b>   |                |                |                |                |                |                |                |
| <b>SNL 3188</b>   |                |                |                |                |                |                |                |
| <b>SNL 3192</b>   |                |                |                |                |                |                |                |
| <b>SNL 3196</b>   |                |                |                |                |                |                |                |

For SNL 3076 to SNL 30/500 and SNL 3168 to SNL 3196, inclusive, please consult SKF

Table 3

## Special seals

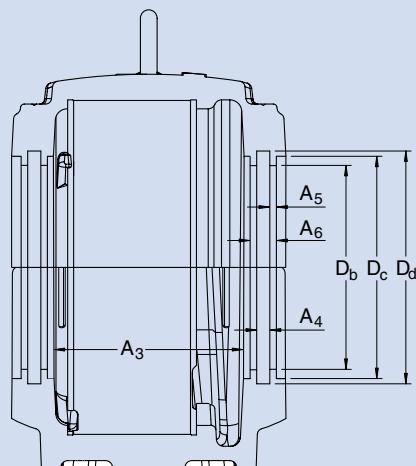

Applications where, for some reason or other, the standard seals cannot be used must be fitted with special seals. The SNL housings can be supplied without seals for such applications and are relatively easy to equip with special seals. It is recommended that housings of series SNL .. G are used rather than those of series SNL as they have a comparatively larger bore at the shaft entrance. There is therefore more room to accommodate a seal, so that there is more choice as regards seal design.

Special seals are not normally supplied by SKF. Therefore, the relevant housing dimensions are given in **Tables 2 and 3**.

| Housing Size        | Dimensions     |                |                |                |                |                |                |
|---------------------|----------------|----------------|----------------|----------------|----------------|----------------|----------------|
|                     | A <sub>3</sub> | A <sub>4</sub> | A <sub>5</sub> | A <sub>6</sub> | D <sub>b</sub> | D <sub>c</sub> | D <sub>d</sub> |
| –                   | mm             |                |                |                |                |                |                |
| <b>SNL 3036 G</b>   | 156            | 11             | 5,5            | 22             | 221,4          | 236,4          | 245,4          |
| <b>SNL 3038 G</b>   | 166            | 11             | 5,5            | 22             | 221,4          | 236,4          | 245,4          |
| <b>SNL 3040 G</b>   | 184            | 11             | 5,5            | 22             | 241,4          | 256,4          | 265,4          |
| <b>SNL 3044 G</b>   | 203            | 11             | 5,5            | 22             | 261,6          | 276,6          | 285,6          |
| <b>SNL 3048 G</b>   | 211            | 11             | 5,5            | 22             | 281,6          | 296,6          | 305,6          |
| <b>SNL 3052 G</b>   | 228            | 11             | 5,5            | 22             | 301,6          | 316,8          | 325,6          |
| <b>SNL 3056 G</b>   | 247            | 11             | 5,5            | 22             | 321,8          | 336,8          | 345,8          |
| <b>SNL 3060 G</b>   | 247            | 11             | 5,5            | 22             | 341,8          | 356,8          | 365,8          |
| <b>SNL 3064 G</b>   | 277            | 11             | 5,5            | 22             | 361,8          | 376,8          | 385,8          |
| <b>SNL 3068 G</b>   | 295            | 11             | 5,5            | 22             | 381,8          | 396,8          | 405,8          |
| <b>SNL 3072 G</b>   | 293            | 11             | 5,5            | 22             | 401,8          | 416,8          | 425,8          |
| <b>SNL 3076 G</b>   |                |                |                |                |                |                |                |
| <b>SNL 3080 G</b>   |                |                |                |                |                |                |                |
| <b>SNL 3084 G</b>   |                |                |                |                |                |                |                |
| <b>SNL 3088 G</b>   |                |                |                |                |                |                |                |
| <b>SNL 3092 G</b>   |                |                |                |                |                |                |                |
| <b>SNL 3096 G</b>   |                |                |                |                |                |                |                |
| <b>SNL 30/500 G</b> |                |                |                |                |                |                |                |
| <b>SNL 3134 G</b>   | 157            | 11             | 5,5            | 22             | 201,4          | 216,4          | 225,4          |
| <b>SNL 3136 G</b>   | 166            | 11             | 5,5            | 22             | 221,4          | 236,4          | 245,4          |
| <b>SNL 3138 G</b>   | 185            | 11             | 5,5            | 22             | 221,4          | 236,4          | 245,4          |
| <b>SNL 3140 G</b>   | 204            | 11             | 5,5            | 22             | 241,4          | 256,4          | 265,4          |
| <b>SNL 3144 G</b>   | 213            | 11             | 5,5            | 22             | 261,6          | 276,6          | 285,6          |
| <b>SNL 3148 G</b>   | 230            | 11             | 5,5            | 22             | 281,6          | 296,6          | 305,6          |
| <b>SNL 3152 G</b>   | 248            | 11             | 5,5            | 22             | 301,6          | 316,8          | 325,6          |
| <b>SNL 3156 G</b>   | 248            | 11             | 5,5            | 22             | 321,8          | 336,8          | 345,8          |
| <b>SNL 3160 G</b>   | 278            | 11             | 5,5            | 22             | 341,8          | 356,8          | 365,8          |
| <b>SNL 3164 G</b>   | 297            | 11             | 5,5            | 22             | 361,8          | 376,8          | 385,8          |
| <b>SNL 3168 G</b>   |                |                |                |                |                |                |                |
| <b>SNL 3172 G</b>   |                |                |                |                |                |                |                |
| <b>SNL 3176 G</b>   |                |                |                |                |                |                |                |
| <b>SNL 3180 G</b>   |                |                |                |                |                |                |                |
| <b>SNL 3184 G</b>   |                |                |                |                |                |                |                |
| <b>SNL 3188 G</b>   |                |                |                |                |                |                |                |
| <b>SNL 3192 G</b>   |                |                |                |                |                |                |                |
| <b>SNL 3196 G</b>   |                |                |                |                |                |                |                |

For SNL 3076 G to SNL 30/500 G and SNL 3168 G to SNL 3196 G, inclusive, please consult SKF

Sealing groove dimensions

Table 4

| Housing Size | Bearing | Dimensions   |                            |       |       |
|--------------|---------|--------------|----------------------------|-------|-------|
|              |         | $b_a$<br>min | $b_a$<br>max <sup>1)</sup> | $b_b$ | $b_c$ |
| mm           |         |              |                            |       |       |
| SNL 3036     | 23036   | 72           | 102                        | 66,5  | 107,5 |
|              | 24036   | 85           | 102                        | 79,5  | 107,5 |
| SNL 3038     | 23038   | 73           | 108                        | 68    | 113,5 |
|              | 24038   | 86           | 108                        | 80,5  | 113,5 |
| SNL 3040     | 23040   | 78           | 112                        | 72,5  | 117,5 |
|              | 24040   | 91           | 112                        | 86    | 117,5 |
| SNL 3044     | 23044   | 91           | 122                        | 86    | 127,5 |
|              | 24044   | 105          | 122                        | 100   | 127,5 |
| SNL 3048     | 23048   | 97           | 128                        | 92    | 133,5 |
|              | 24048   | 110          | 128                        | 105   | 133,5 |
| SNL 3052     | 23052   | 103          | 136                        | 98    | 141,5 |
|              | 24052   | 121          | 136                        | 116   | 141,5 |
| SNL 3056     | 23056   | 108          | 146                        | 103   | 151,5 |
|              | 24056   | 125          | 146                        | 120   | 151,5 |
| SNL 3060     | 23060   | 118          | 149                        | 113   | 154,5 |
|              | 24060   | 139          | 149                        | 134   | 154,5 |
| SNL 3064     | 23064   | 121          | 170                        | 115,5 | 175,5 |
|              | 24064   | 140          | 170                        | 135   | 175,5 |
| SNL 3068     | 23068   | 130          | 181                        | 124,5 | 186,5 |
|              | 24068   | 153          | 181                        | 148   | 186,5 |
| SNL 3072     | 23072   | 130          | 181                        | 125   | 186,5 |
|              | 24072   | 153          | 181                        | 148   | 186,5 |
| SNL 3076     | 23076   |              |                            |       |       |
|              | 24076   |              |                            |       |       |
| SNL 3080     | 23080   |              |                            |       |       |
|              | 24080   |              |                            |       |       |
| SNL 3084     | 23084   |              |                            |       |       |
|              | 24084   |              |                            |       |       |
| SNL 3088     | 23088   |              |                            |       |       |
|              | 24088   |              |                            |       |       |
| SNL 3092     | 23092   |              |                            |       |       |
|              | 24092   |              |                            |       |       |
| SNL 3096     | 23096   |              |                            |       |       |
|              | 24096   |              |                            |       |       |
| SNL 30/500   | 230/500 |              |                            |       |       |
|              | 240/500 |              |                            |       |       |
| SNL 3134     | 23134   | 78           | 102                        | 73    | 107,5 |
| SNL 3136     | 23136   | 83           | 108                        | 78    | 113,5 |
| SNL 3138     | 23138   | 88           | 112                        | 83    | 117,5 |
| SNL 3140     | 23140   | 93           | 122                        | 88    | 127,5 |
| SNL 3144     | 23144   | 100          | 128                        | 95    | 133,5 |
| SNL 3148     | 23148   | 106          | 136                        | 101   | 141,5 |
| SNL 3152     | 23152   | 116          | 146                        | 111   | 151,5 |
| SNL 3156     | 23156   | 119          | 149                        | 114   | 154,5 |
| SNL 3160     | 23160   | 138          | 170                        | 133   | 175,5 |
| SNL 3164     | 23164   | 149          | 181                        | 144   | 186,5 |
| SNL 3168     | 23168   |              |                            |       |       |
| SNL 3172     | 23172   |              |                            |       |       |
| SNL 3176     | 23176   |              |                            |       |       |
| SNL 3180     | 23180   |              |                            |       |       |
| SNL 3184     | 23184   |              |                            |       |       |
| SNL 3188     | 23188   |              |                            |       |       |
| SNL 3192     | 23192   |              |                            |       |       |
| SNL 3196     | 23196   |              |                            |       |       |

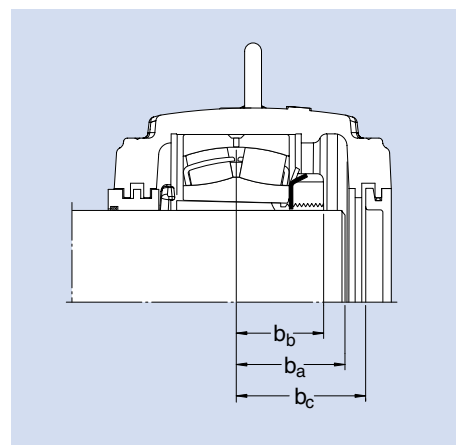
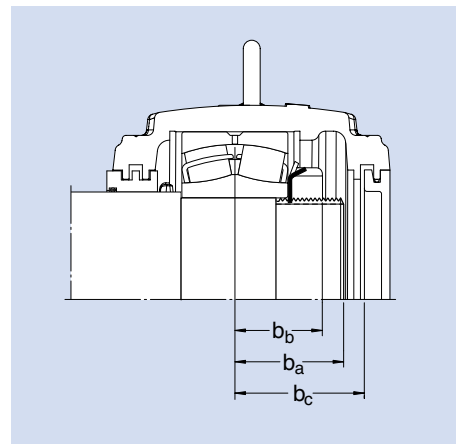

<sup>1)</sup> For non-locating arrangements which are not mounted centrally in the bearing seating, the value of  $b_a$  max must be correspondingly reduced

For SNL 3076 to SNL 30/500 and SNL 3168 to SNL 3196, inclusive, please consult SKF

*Permissible length of shaft end*

## End covers

For housings mounted at the ends of shafts, the one opening should be fitted with an end cover which fits into the seal groove (→ **fig 4**). Details of the permissible length of the shaft end can be found in **Table 4**. The end covers are of cast iron and are inserted with a hollow O-ring cord of silicone rubber in the seal groove in the housing. The end covers are suitable for operating temperatures in the range  $-50$  to  $+200$  °C.

The standard end cover is designated by the prefix ETS followed by the housing size identification, e.g. ETS 34. End covers for oil lubricated SNL housings are identified by suffix R, e.g. ETS 34 R.

## Locating rings

The bearing seating in the housing is sufficiently wide to enable the bearing to be displaced axially. Bearings which are to locate a shaft axially in both directions (locating bearings) must always be fixed axially in position in the housing bore by locating rings at both sides (→ **fig 5**).

CARB bearings are non-locating bearings and cannot take axial loads. Since axial displacement is accommodated within a CARB bearing (together with any misalignment) it is necessary to locate the outer ring axially in its seating by inserting locating rings at each side of the bearing.

The locating rings are identified by the prefix FRB followed by figures giving the width/outside diameter in millimetres, e.g. FRB 10/280.

*Housing with end cover*

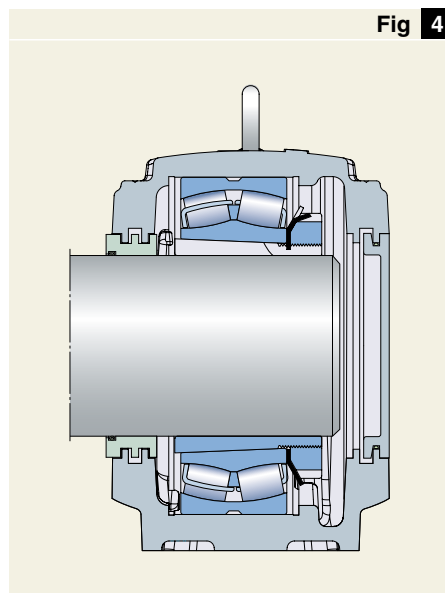

*Housing with locating rings at both sides of bearing*

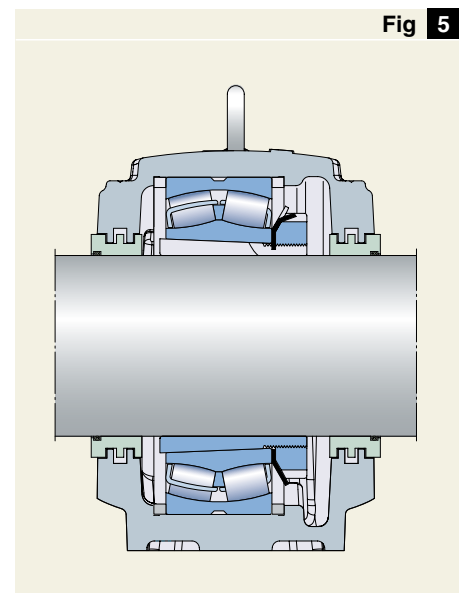

# Application advice for trouble-free operation

Condition monitoring is recommended for SNL plummer blocks particularly if they are used on machines where failures would cause production stoppages. The early recognition and trending of the degradation of the machine and machine parts make it possible to analyse the cause and to be able to plan for corrective maintenance actions in good time.

Extensive monitoring experience and a knowledge of the dynamic behaviour of machines, machine components and bearings where there is incipient damage allows SKF to recommend two powerful signal processing techniques which can be used for condition monitoring.

## Vibration velocity

The RMS (root mean square) of the velocity of vibrations in the frequency range 10 Hz to 1 kHz has been used with great success to measure phenomena such as imbalance, misalignment, resonance etc. High levels of velocity vibration can be generated by poor machine conditions such as improper clearances, imbalance, misalignment, weak foundations, bent rotors, out-of-round, belt problems or damaged fan blades. The ISO Standard 10816-1:1995 contains recommendations for reference values for the RMS velocity values measured on different classes of machines and machine parts. These recommendations give a clear and quantifiable measure for the changes in machine condition. Vibration velocity expressed as an overall RMS value in the 10 Hz to 1 kHz frequency range provides minimal information on defects in rolling element bearings or gear mesh problems. These types of defect can now be easily detected by enveloped acceleration in the higher frequency ranges.

## Enveloped acceleration

Bearing defects can be easily recognised by measurement and analysis of an enveloped acceleration signal of

the higher frequencies generated by the impact signals typical of rolling bearing defects and gear teeth problems. This technique has proved to be



*Electronic cabinet with built-in MCM™ units*



*Multilog on-line system*



*Microlog – portable data collector and analyser*

extremely reliable in the detection of incipient bearing defects. The low frequencies generated by imbalance, misalignment etc. are not measured and diagnosed within the enveloped acceleration process.

- Condition monitoring and diagnosis with permanently installed monitoring systems

This type of monitoring makes it possible to check the condition using MCM™ (Mechanical Condition Monitor) for a single measuring point or the multilog LMU (Local Monitoring Unit) which sequentially monitors several measuring points. The MCM™ system should be applied where an economical solution is required (e.g. for fans). The measurement output can be directly connected to a control or DCS (Digital Control System). A relay output is also available to shut down the machine or section of the plant.

- Condition monitoring and diagnosis with a portable data collector and analyser

In this case the condition is monitored using a portable data collector/analyser at appropriate points on the machine. Where a measurement point is difficult to access, permanently installed sensors can be used. These can be connected by cable to a connection box accessible to the data collector.

On-line condition monitoring uses fixed sensors which are always connected to the data collector. SNL housings have appropriate points for sensors (→ fig 1). Measurement points 1 and 2 are perpendicular to the shaft and correspond best to ISO 10816-1:1995.

Measurement point 2 should be used on SNL housings where the load acts towards the base plate. Measurement point 1 is intended for when the housing is hung from its support or when the load acts away from the base plate.

For additional information about condition monitoring and the measurement tools and systems available from SKF please contact the SKF application engineering service.

#### Measurement points for condition monitoring



Fig 1

# Lubrication

SNL plummer block housings are so designed that the bearings in them can be lubricated with grease or oil, although grease lubrication is generally preferable. The lubricant should be selected with reference to the operating conditions. Relevant information will be found in the SKF General Catalogue and other SKF publications.

## Grease lubrication

In the majority of applications, the amount of grease applied to the SNL housings when mounting (first fill) or after an inspection is adequate until the next planned inspection.

Certain operating conditions, e.g. high speeds, high temperatures or heavy loads, may mean that more frequent relubrication is necessary. **Table 1** gives guideline values for the grease quantities to be applied for the first fill and for relubrication. Markings in each corner inside the base give an indication of the grease level for the first fill (→ **fig 2**).

There are three drilled and tapped holes for a grease nipple AH 1/8-27 PTF in the housing: two in the cap and one in the base. These holes are closed by metallic plugs. The two markings at the outer sides of the central ridge indicate

the position for lubrication holes for the seals.

A grease nipple AH 1/8-27 PTF is supplied with the housing. The grease nipple kit also contains a plastic grease nipple protector, a grease nipple M1 G 1/8 and an adapter LAPN 1/8. This adapter transforms the standard drilled 1/8-27 NPSF thread to a G 1/4 which enables the use of grease lubricators such as SKF SYSTEM 24.

It is recommended that spherical roller bearings having a lubrication groove and three holes in the outer ring (designation suffix W33) be lubricated via this feature (→ **fig 3**). In this case the relubrication hole in the base or in the centre of the cap should be used.

It should be noted that when spherical roller bearings are to be relubricated via the outer ring, they should be rotated. If outer ring relubrication is not possible or if CARB bearings are used the standard grease nipple supplied with the housing should be inserted in the hole on the side of the cap and used for this purpose (→ **fig 4**). If it is desired to use a grease nipple other than that supplied with the housing, adapters are available which make a reworking of the available drilled and tapped hole unnecessary.

Grease level markings for first fill

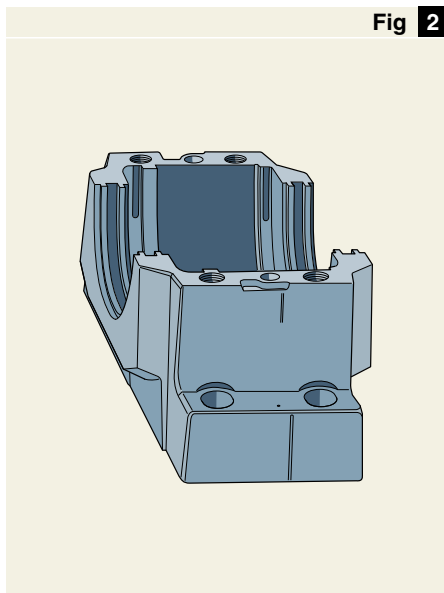

Lubricating the bearing via the outer ring

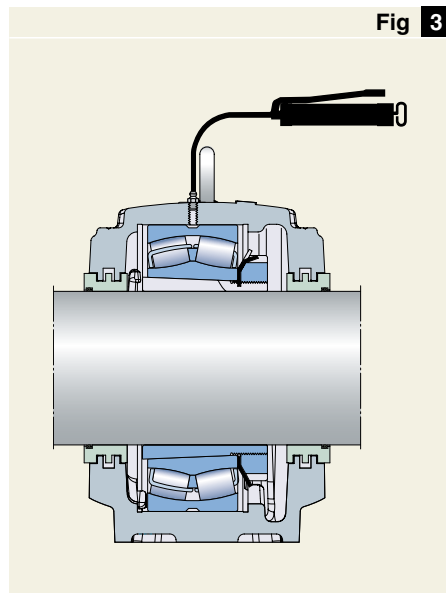

Grease quantities

| Table 1      |                          |               |
|--------------|--------------------------|---------------|
| Housing Size | Grease quantities        |               |
|              | First fill <sup>1)</sup> | Relubrication |
| –            | kg                       |               |
| SNL 3036     | 1,2                      | 0,10          |
| SNL 3038     | 1,5                      | 0,11          |
| SNL 3040     | 1,9                      | 0,13          |
| SNL 3044     | 2,4                      | 0,15          |
| SNL 3048     | 2,8                      | 0,17          |
| SNL 3052     | 3,6                      | 0,21          |
| SNL 3056     | 4,5                      | 0,22          |
| SNL 3060     | 4,6                      | 0,27          |
| SNL 3064     | 6,5                      | 0,29          |
| SNL 3068     | 8,1                      | 0,35          |
| SNL 3072     | 8,1                      | 0,36          |
| SNL 3076     |                          |               |
| SNL 3080     |                          |               |
| SNL 3084     |                          |               |
| SNL 3088     |                          |               |
| SNL 3092     |                          |               |
| SNL 3096     |                          |               |
| SNL 30/500   |                          |               |
| SNL 3134     | 1,1                      | 0,12          |
| SNL 3136     | 1,4                      | 0,14          |
| SNL 3138     | 1,8                      | 0,17          |
| SNL 3140     | 2,3                      | 0,19          |
| SNL 3144     | 2,7                      | 0,22          |
| SNL 3148     | 3,4                      | 0,26          |
| SNL 3152     | 4,3                      | 0,32          |
| SNL 3156     | 4,4                      | 0,34          |
| SNL 3160     | 6,2                      | 0,40          |
| SNL 3164     | 7,7                      | 0,48          |
| SNL 3168     |                          |               |
| SNL 3172     |                          |               |
| SNL 3176     |                          |               |
| SNL 3180     |                          |               |
| SNL 3184     |                          |               |
| SNL 3188     |                          |               |
| SNL 3192     |                          |               |
| SNL 3196     |                          |               |

<sup>1)</sup> Fills approximately 40 % of the free space in the housing

For SNL 3076 to SNL 30/500 and SNL 3168 to SNL 3196, inclusive, please consult SKF

Table 2

**Recommended dimensions for grease escape hole**

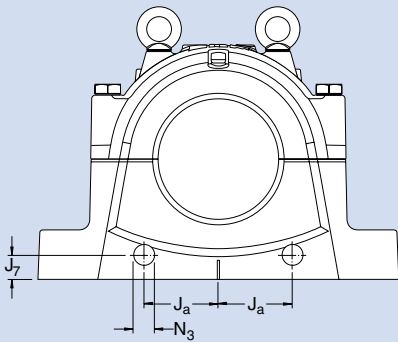

| Housing Size | Dimensions |    |    |
|--------------|------------|----|----|
|              | Ja         | J7 | N3 |
| —            | mm         |    |    |
| SNL 3036     | 105        | 34 | 30 |
| SNL 3038     | 110        | 38 | 30 |
| SNL 3040     | 120        | 36 | 30 |
| SNL 3044     | 120        | 36 | 30 |
| SNL 3048     | 130        | 42 | 40 |
| SNL 3052     | 145        | 43 | 40 |
| SNL 3056     | 150        | 44 | 40 |
| SNL 3060     | 165        | 51 | 40 |
| SNL 3064     | 180        | 53 | 40 |
| SNL 3068     | 180        | 53 | 40 |
| SNL 3072     | 180        | 53 | 40 |
| SNL 3076     |            |    |    |
| SNL 3080     |            |    |    |
| SNL 3084     |            |    |    |
| SNL 3088     |            |    |    |
| SNL 3092     |            |    |    |
| SNL 3096     |            |    |    |
| SNL 30/500   |            |    |    |
| SNL 3134     | 105        | 34 | 30 |
| SNL 3136     | 110        | 38 | 30 |
| SNL 3138     | 120        | 36 | 30 |
| SNL 3140     | 120        | 36 | 30 |
| SNL 3144     | 130        | 42 | 40 |
| SNL 3148     | 145        | 43 | 40 |
| SNL 3152     | 150        | 44 | 40 |
| SNL 3156     | 165        | 51 | 40 |
| SNL 3160     | 180        | 53 | 40 |
| SNL 3164     | 180        | 53 | 40 |
| SNL 3168     |            |    |    |
| SNL 3172     |            |    |    |
| SNL 3176     |            |    |    |
| SNL 3180     |            |    |    |
| SNL 3184     |            |    |    |
| SNL 3188     |            |    |    |
| SNL 3192     |            |    |    |
| SNL 3196     |            |    |    |

The dimensions are those recommended when the standard grease nipple AH 1/8-27 PTF is used (supplied with the housing) but can also be applied if nipples having threads R 1/8, KR 1/8, M 10×1 or G 1/4 (with adapter LAPN 1/8) are used. The recommendations also apply if grease dispensers, e.g. SKF SYSTEM 24 are used.

For SNL 3076 to SNL 30/500 and SNL 3168 to SNL 3196, inclusive, please consult SKF

Where the bearings are mounted on adapter sleeves, the grease should be introduced at the side opposite to the lock nut of the sleeve.

If frequent relubrication is required, it is advisable to provide the housing with grease escape holes (→ fig 5) through which excess grease can escape. Recommended dimensions will be found in Table 2. SNL housings with grease escape holes in the base can be supplied. This housing design is identified by the suffix V, e.g. SNL 3134 V.

SNL housings can also be equipped with grease lubricators. Recommended are the SKF SYSTEM 24 lubricators (e.g. LAGD 125/WA2) which provide a reliable alternative to manual relubrication.

Lubricating the bearing from the side

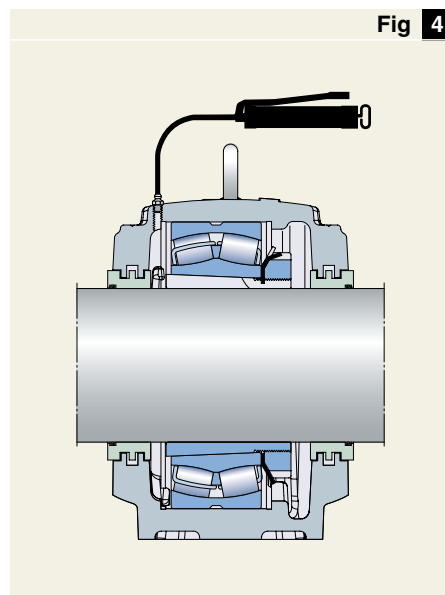

Housing with grease escape hole

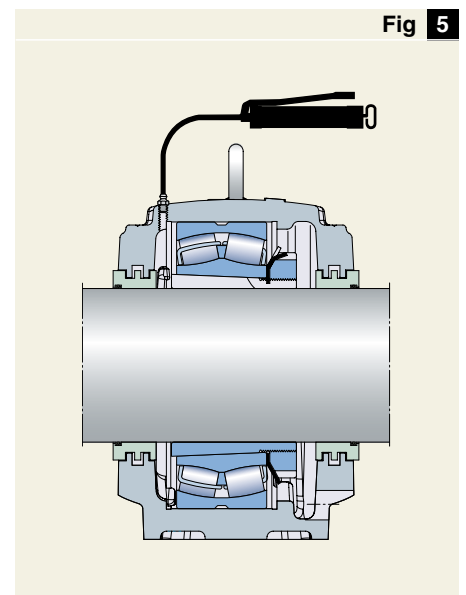

### Oil lubrication

The new SNL 30 and SNL 31 housings can be used for oil lubrication at relatively high speeds. When using oil, however, the specially developed U-design seals should be incorporated to avoid oil loss from the housing (→ fig 6). These seals are described on page 14. In order for these seals to be used, the housing must be modified so that SNL housings for oil lubrication are only supplied complete with seals.

Oil lubricated SNL housings can also be equipped with oil levellers, LAHD series, which are designed for automatic adjustment of the optimal oil lubrication level within the bearing housing.

### Housing for oil lubrication

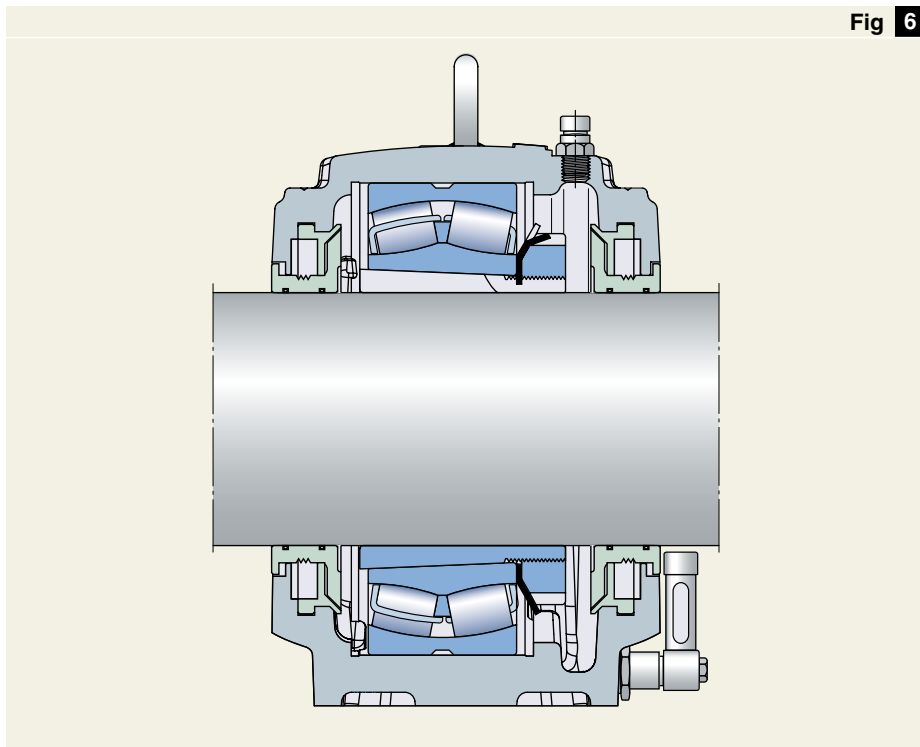

Fig 6

## Mounting

SNL housings together with SKF bearings are robust and operationally reliable bearing arrangements which have long lives. However, if they are to achieve their full potential and not fail prematurely, they must be properly mounted. Incorrect procedures or unsuitable tools can influence life negatively.

When mounting the housings it should be remembered that the housings are asymmetrical internally and therefore the bearings are not always mounted in the centre of the housing.

Vertical markings on the housing base end faces indicates the location of the centre of the bearing seating.

### Mounting the bearing

The bearings can be mounted either on a tapered seating – normally for SNL housings in the form of an adapter sleeve – or on a cylindrical seating. When a bearing is correctly mounted on a sleeve there will be interference fits between the inner ring, sleeve and shaft. The degree of interference is determined by how far the bearing is driven up on the sleeve and either the internal clearance reduction or the axial drive-up distance can be used as a measure. The clearance reduction in spherical roller bearings can be measured using a feeler gauge, or the SKF drive-up method can be used. Information will be sent on request.

CARB bearings can also be mounted on cylindrical as well as tapered seatings. For CARB bearings either the clearance reduction or the axial drive-up distance should be measured. When using a feeler gauge to measure clearance reduction it is important that the inner and outer rings of the bearing are not displaced with respect to each other. The SKF drive-up method can also be applied.

Adapter sleeves with the designation OH .. H in the tables indicate that the sleeves are provided with the necessary ducts to enable them to be mounted using the oil injection method. Oil is supplied to the nut side of the sleeve.

Bearings with cylindrical bore are normally mounted with an interference fit on the shaft. Appropriate shaft tolerances should be selected. The recom-

mendations applying to spherical roller bearings also apply to CARB bearings.

Details of mounting tools as well as the SKF drive-up method can be found on the SKF CD-ROM MP282 which will be sent on request.

**Support surface for housing base**

To guarantee long bearing service life it is recommended that the support surface for the housing is finished to  $R_a \leq 12,5 \mu\text{m}$ . The flatness (planicity) tolerance should be to IT7. For moderate demands IT8 may be satisfactory.

**Dowel pins**

SNL housings are designed for loads acting vertically to the housing base support. If they are to be subjected to moderate or heavy loads acting parallel to the base support, a stop should be provided, or the housing should be pinned to its support. Recommendations for the position and size of holes to take dowel pins are given in **Table 3**.

**Attachment bolts**

It is recommended that hexagon headed bolts to strength class 8.8 according to the European Standard EN 24014 should be used. If the load does not act vertically to the base, it may be necessary to use stronger, class 10.9 bolts. Details of the appropriate tightening torques for the bolts to class 8.8 are given in **Table 2** on page 32.



Table 3

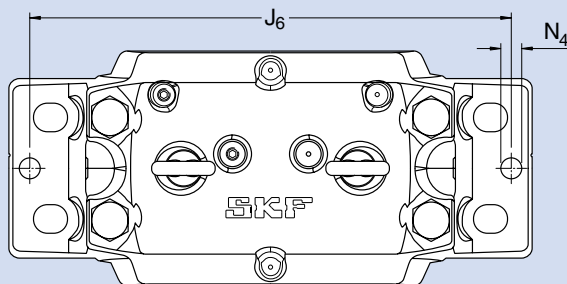

| Housing Size | Dimensions     |                    | Housing Size | Dimensions     |                    |
|--------------|----------------|--------------------|--------------|----------------|--------------------|
|              | J <sub>6</sub> | N <sub>4</sub> max |              | J <sub>6</sub> | N <sub>4</sub> max |
| —            | mm             |                    | —            | mm             |                    |
| SNL 3036     | 470            | 20                 | SNL 3134     | 470            | 20                 |
| SNL 3038     | 490            | 20                 | SNL 3136     | 490            | 20                 |
| SNL 3040     | 520            | 20                 | SNL 3138     | 520            | 20                 |
| SNL 3044     | 560            | 20                 | SNL 3140     | 560            | 20                 |
| SNL 3048     | 590            | 20                 | SNL 3144     | 590            | 20                 |
| SNL 3052     | 650            | 20                 | SNL 3148     | 650            | 20                 |
| SNL 3056     | 720            | 20                 | SNL 3152     | 720            | 20                 |
| SNL 3060     | 740            | 20                 | SNL 3156     | 740            | 20                 |
| SNL 3064     | 770            | 25                 | SNL 3160     | 770            | 25                 |
| SNL 3068     | 830            | 25                 | SNL 3164     | 830            | 25                 |
| SNL 3072     | 830            | 25                 | SNL 3168     |                |                    |
| SNL 3076     |                |                    | SNL 3172     |                |                    |
| SNL 3080     |                |                    | SNL 3176     |                |                    |
| SNL 3084     |                |                    | SNL 3180     |                |                    |
| SNL 3088     |                |                    | SNL 3184     |                |                    |
| SNL 3092     |                |                    | SNL 3188     |                |                    |
| SNL 3096     |                |                    | SNL 3192     |                |                    |
| SNL 30/500   |                |                    | SNL 3196     |                |                    |

For SNL 3076 to SNL 30/500 and SNL 3168 to SNL 3196, inclusive, please consult SKF

Position and size of dowel pin holes

## Mounting SNL 30 and SNL 31 housings with labyrinth seals

Before starting installation work, the following instructions should be carefully read.

**1.** Ensure that the environment is clean. Check the dimensional and form accuracy of the shaft seating.

**2.** Check that the surface roughness of the support surface  $R_a \leq 12,5 \mu\text{m}$ . The flatness (planicity) tolerance should be to IT7. For moderate demands IT8 may be satisfactory.

**3.** If the bearing is mounted on an adapter sleeve, determine the position of the housing. The grease nipple arranged at one side of the housing cap (for improved lubrication) should always be at the side opposite to the sleeve nut. It is necessary to consider the complete housing as the base and cap will only fit together as supplied.

**4.** Position the housing on the support surface. Fit the attachment bolts but do not tighten them.

**5.** Mount the first labyrinth seal on the shaft in the correct position.

**6.** Mount the bearing on the shaft – either directly on a stepped shaft or using an adapter sleeve. Completely fill the bearing with grease. The housing base should be filled with grease up to the markings in each corner inside the base (→ **Table 1**, **page 20**).

**7.** Mount the second labyrinth ring on the shaft in the correct position. If the housing is to be used at a shaft end, the second labyrinth ring is omitted and an end cover inserted in the housing base instead.

**8.** Lay the shaft with bearing and labyrinth ring(s) in the housing base.

**9.** Put the locating ring(s) (when needed) at each side of the bearing.

NB. Locating rings are only used for locating bearing arrangements, except for CARB bearings which, although always non-locating, must always be mounted with locating rings.

**10.** Carefully align the housing base. Vertical markings on the housing base ends and side faces showing the bearing seating centre can facilitate this. Then lightly tighten the attachment bolts.

**11.** The housing cap should be placed over the base and the cap bolts (to join cap and base) tightened to the torque specified in **Table 2** on **page 32**. The cap and base of one housing are not interchangeable with those of other housings. The cap and base should be checked to see that they bear the same consecutive number.

**12.** Fully tighten the attachment bolts in the housing base. Recommended tightening torques are given in **Table 2** on **page 32**.

**13.** Finally insert the hollow O-ring cords of synthetic rubber in the grooves in the labyrinth rings. This can be done using a screwdriver while turning the shaft.

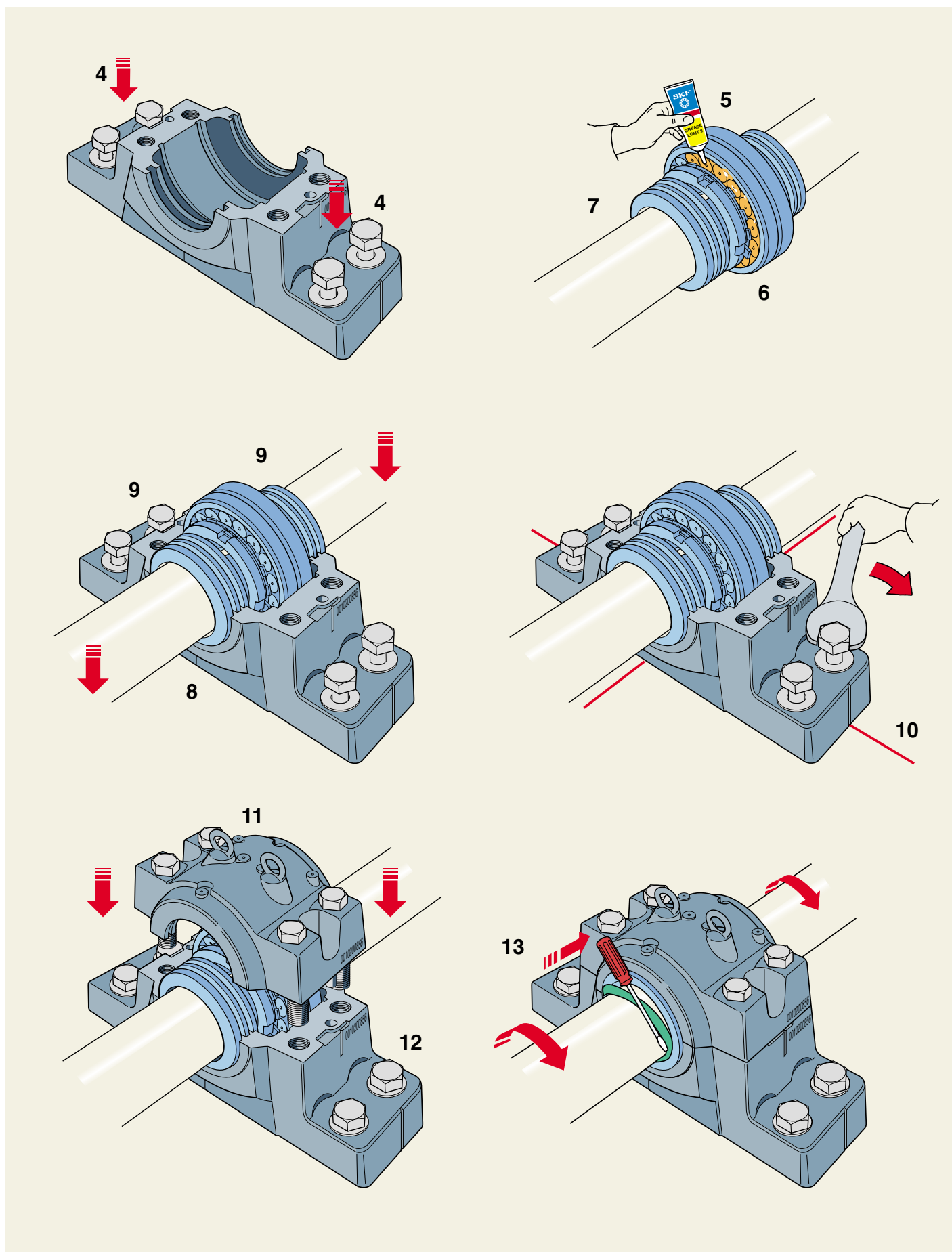

## Mounting SNL 30 and SNL 31 housings with taconite seals

Before starting installation work, the following instructions should be carefully read.

1. Ensure that the environment is clean. Check the dimensional and form accuracy of the shaft seating.

2. Check that the surface roughness of the support surface  $R_a \leq 12,5 \mu\text{m}$ . The flatness (planicity) tolerance should be to IT7. For moderate demands IT8 may be satisfactory.

3. If the bearing is mounted on an adapter sleeve, determine the position of the housing. The grease nipple arranged at one side of the housing cap (for improved lubrication) should always be at the side opposite to the sleeve nut. It is necessary to consider the complete housing as the base and cap will only fit together as supplied.

4. Position the housing on the support surface. Fit the attachment bolts but do not tighten them.

5. Slide the parts for the first seal to the correct position on the shaft. The lip of the V-ring should point towards the bearing. Do not tighten the grub screws.

6. Mount the bearing on the shaft – either directly on a stepped shaft or using an adapter sleeve. Completely fill the bearing with grease. The housing base should be filled with grease up to the markings in each corner inside the base (→ **Table 1**, **page 20**).

7. Mount the second seal according to point 5. If the housing is to be used at a shaft end, the second seal is omitted and an end cover inserted in the housing base instead.

8. Check that the O-ring is in the correct position on the seal outside diameter.

9. Lay the shaft with bearing and seals in the housing base taking care that the O-rings are not damaged.

10. Put the locating ring(s) (when needed) at each side of the bearing.

NB. Locating rings are only used for locating bearing arrangements, except for CARB bearings which, although always non-locating, must always be mounted with locating rings.

11. Carefully align the housing base. Vertical markings on the housing base ends and side faces showing the bearing seating centre can facilitate this. Then lightly tighten the attachment bolts.

12. The housing cap should be placed over the base, taking care that the O-rings are not damaged, and the cap bolts (to join cap and base) tightened to the torque specified in **Table 2** on **page 32**. The cap and base of one housing are not interchangeable with those of other housings. The cap and base should be checked to see that they bear the same consecutive number.

13. Fully tighten the attachment bolts in the housing base. Recommended tightening torques are given in **Table 2** on **page 32**.

14. Adjust the flingers to the correct position and tighten the grub screws. The clearance in the seal must exceed the axial movement of the bearing.

15. Finally, before the first test run, rotate the shaft and supply grease via the nipple until it exudes from the labyrinth rings. The same grease as that used for the bearing should also be used to lubricate the labyrinth rings.

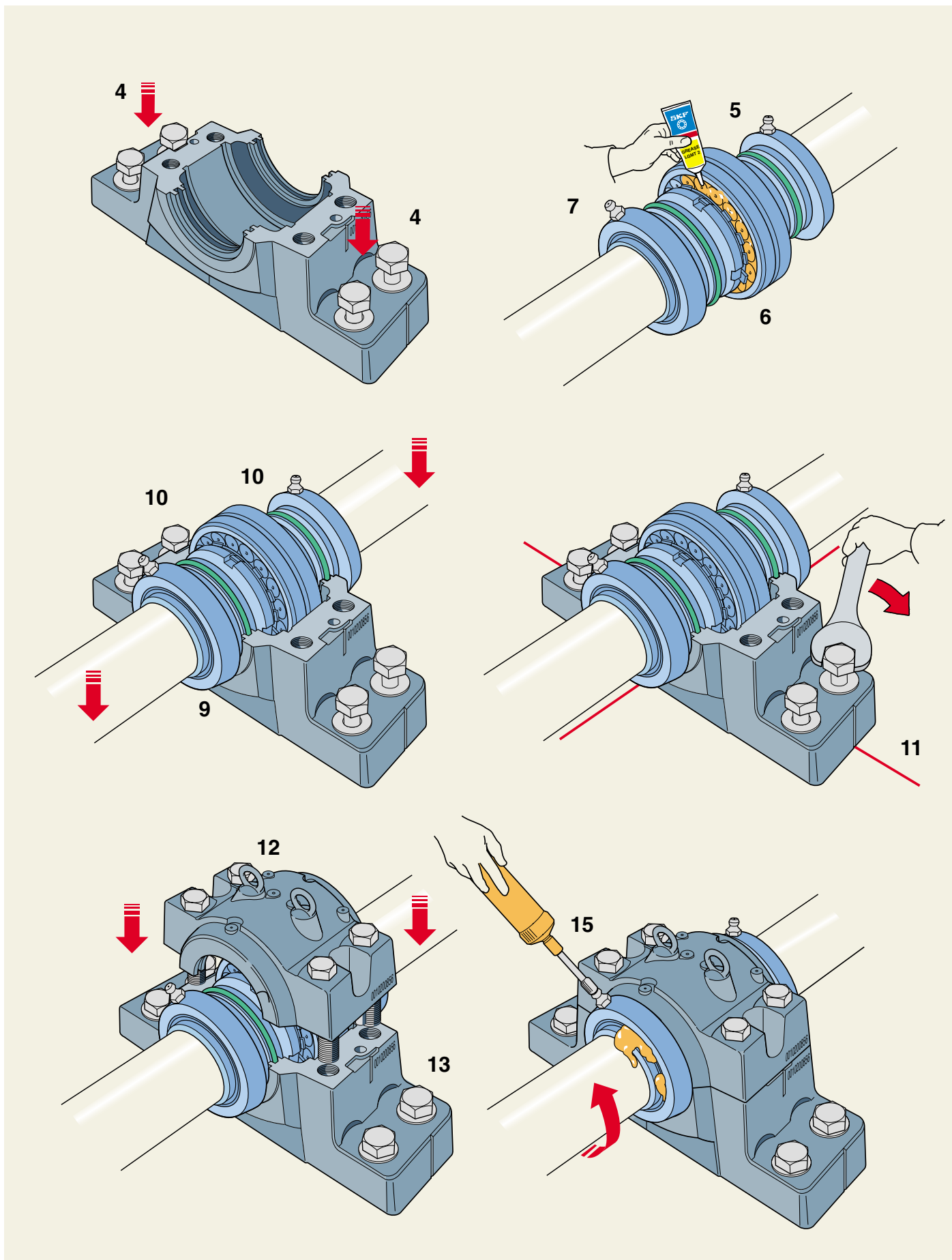

## Mounting SNL 30 and SNL 31 housings with oil seals

Before starting installation work, the following instructions should be carefully read.

1. Ensure that the environment is clean. Check the dimensional and form accuracy of the shaft seating.

2. Check that the surface roughness of the support surface  $R_a \leq 12,5 \mu\text{m}$ . The flatness (planicity) tolerance should be to IT7. For moderate demands IT8 may be satisfactory.

3. If the bearing is mounted on an adapter sleeve, determine the position of the housing. It is necessary to consider the complete housing as the base and cap will only fit together as supplied.

4. Position the housing on the support surface. Fit the attachment bolts but do not tighten them.

5. Cover the shaft with a thin layer of oil. Slide the parts for the first seal to the correct position on the shaft.

6. Mount the bearing on the shaft – either directly on a stepped shaft or using an adapter sleeve.

7. Slide the parts for the second seal to the correct position on the shaft. Keep the locating pin in the outer seal parts in a horizontal position.

8. Lay the shaft with bearing and seal parts in the housing base.

9. Put the locating ring(s) (when needed) at each side of the bearing.

NB. Locating rings are only used for locating bearing arrangements, except for CARB bearings which, although always non-locating, must be mounted with locating rings.

10. Carefully align the housing base. Vertical markings on the housing base ends and side faces showing the bearing seating centre can facilitate this. Then lightly tighten the attachment bolts.

11. Cover the mating surfaces of the housing with oil-resistant sealant, place the housing cap over the base and tighten the cap bolts to the torque specified in **Table 2** on **page 32**. The cap and base of one housing are not interchangeable with those of other housings. The cap and base should be checked to see that they bear the same consecutive number.

12. Fully tighten the attachment bolts in the housing base. Recommended tightening torques are given in **Table 2** on **page 32**.

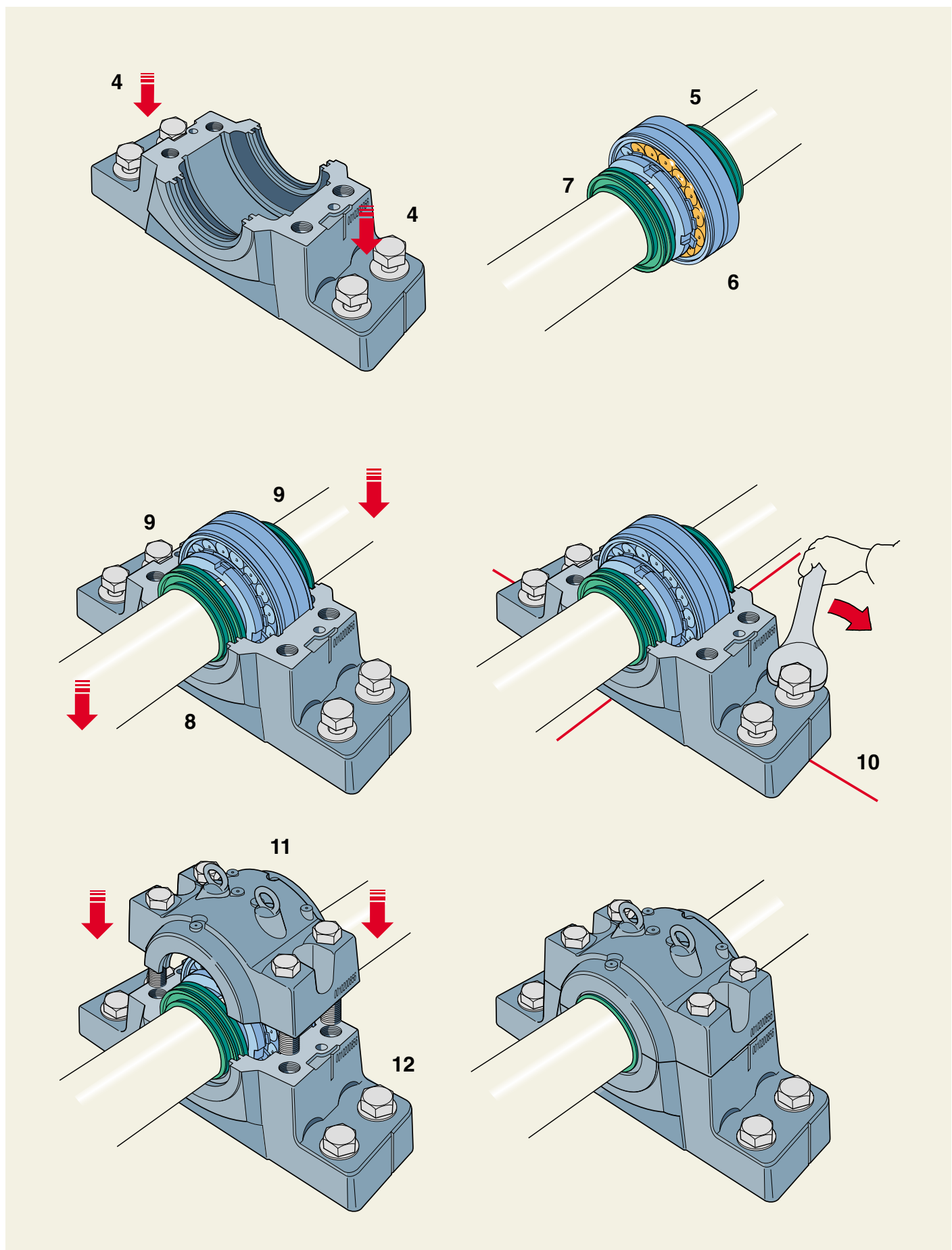

# Designations and housing data

## Designations

The designations used for SNL housings consist of a basic designation which identifies the design, material and size followed by any supplementary design-

nations needed to identify features which differ from the standard design. A dash (–) in the chart indicates that the feature belongs to the standard design.

Designation chart

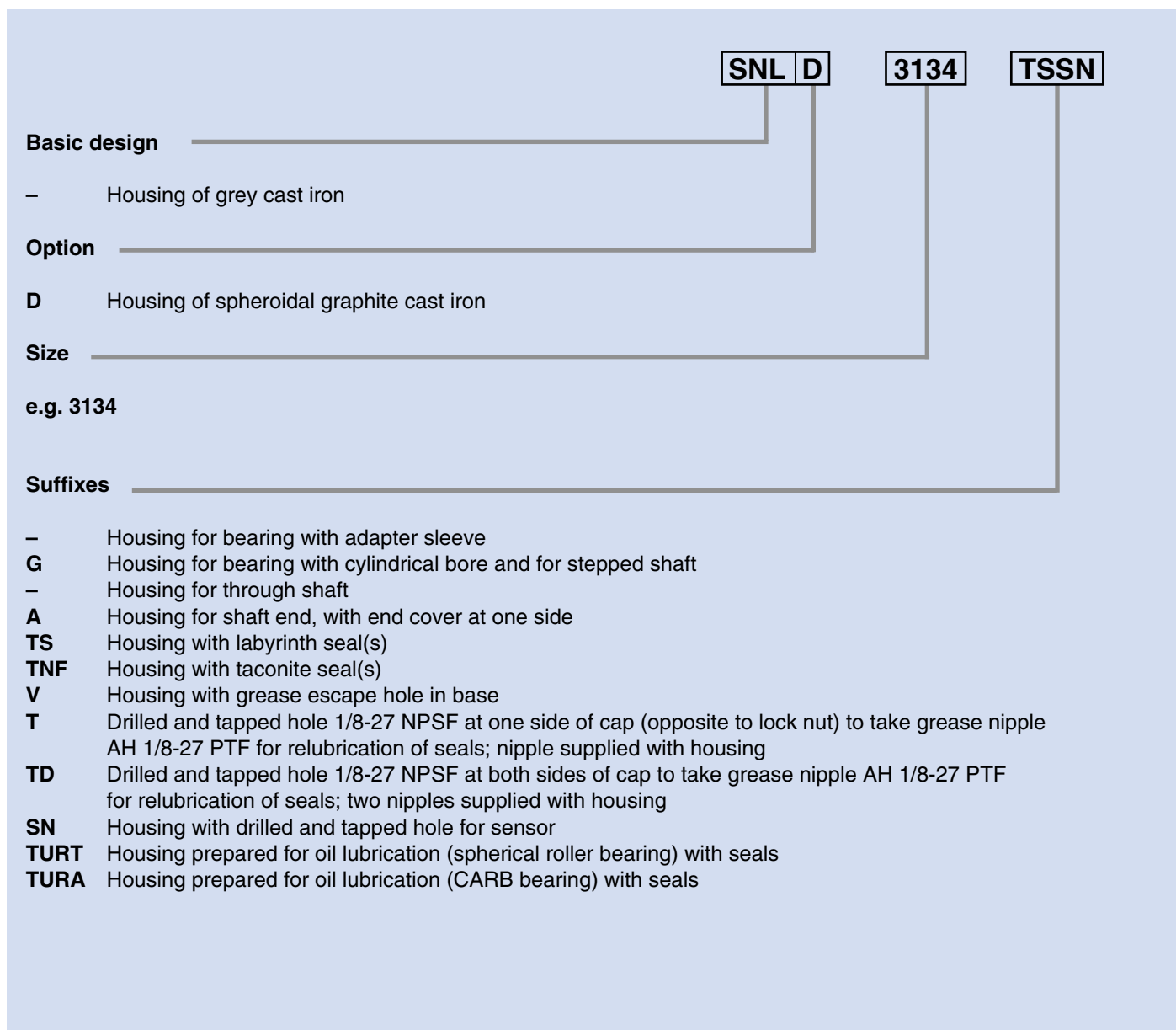

## Load carrying ability

SNL plummer block housings are intended for loads acting vertically towards the base plate (support). If loads acting in other directions occur, checks should be made to ensure that the magnitude of the load is permissible for the housing, the bolts joining the housing cap and base, and for the attachment bolts.

### Load carrying ability of the housing

Guideline values for the breaking load  $P$  of the housing for various load directions are given in **Table 1**. Using these values and a safety factor selected with respect to the operating conditions, the permissible load for the housing can be calculated. In general engineering a safety factor of 6 is often used.

For special purposes where extra strength and resistance to shock loads are required, SKF supplies as standard a range of spheroidal graphite cast iron housings. Spheroidal graphite cast iron housings are designated SNLD followed by the size identification, e.g. SNLD 3134. For housings made of spheroidal graphite cast iron the values of  $P$  in **Table 1** should be multiplied by 1,8.

It is important for the load carrying ability of the housing that the bolts joining cap and base are properly tightened in accordance with the values given in **Table 2**. The axial load carrying capacity of the housing is approximately 65 % of  $P_{180^\circ}$ . For load angles between  $55$  and  $120^\circ$  as well as for axial loads, if the load acting parallel to the base plate (support surface) exceeds 5 % of  $P_{180^\circ}$ , the housing should be pinned to the support or a stop should be provided in the direction of the load.

Table 1

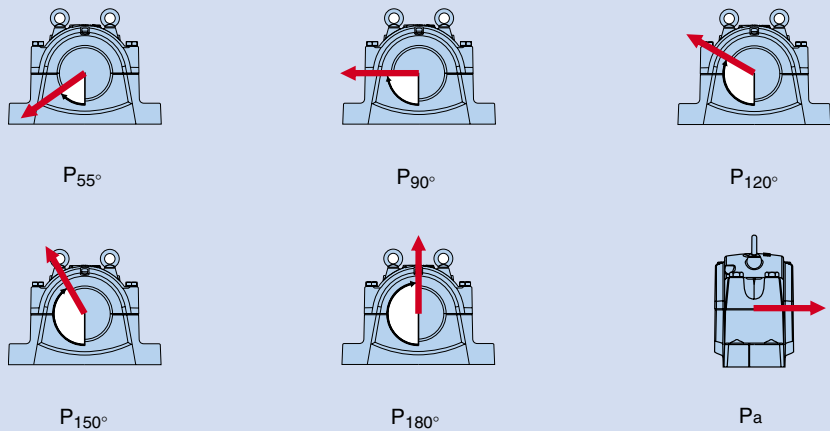

| Housing Size | Breaking loads for SNL housing |                |                 |                 |                 |       |
|--------------|--------------------------------|----------------|-----------------|-----------------|-----------------|-------|
|              | $P_{55^\circ}$                 | $P_{90^\circ}$ | $P_{120^\circ}$ | $P_{150^\circ}$ | $P_{180^\circ}$ | $P_a$ |
| —            | kN                             |                |                 |                 |                 |       |
| SNL 3036     | 2 100                          | 1 000          | 760             | 680             | 850             | 550   |
| SNL 3038     | 2 400                          | 1 150          | 850             | 760             | 950             | 620   |
| SNL 3040     | 2 700                          | 1 300          | 1 000           | 880             | 1 100           | 710   |
| SNL 3044     | 3 200                          | 1 600          | 1 100           | 1 000           | 1 300           | 840   |
| SNL 3048     | 4 000                          | 1 900          | 1 400           | 1 300           | 1 600           | 1 000 |
| SNL 3052     | 4 200                          | 2 000          | 1 500           | 1 400           | 1 700           | 1 100 |
| SNL 3056     | 4 700                          | 2 300          | 1 700           | 1 500           | 1 900           | 1 200 |
| SNL 3060     | 5 000                          | 2 400          | 1 800           | 1 600           | 2 000           | 1 300 |
| SNL 3064     | 6 000                          | 2 900          | 2 200           | 1 900           | 2 400           | 1 500 |
| SNL 3068     | 7 000                          | 3 400          | 2 500           | 2 200           | 2 800           | 1 800 |
| SNL 3072     | 7 000                          | 3 400          | 2 500           | 2 200           | 2 800           | 1 800 |
| SNL 3076     |                                |                |                 |                 |                 |       |
| SNL 3080     |                                |                |                 |                 |                 |       |
| SNL 3084     |                                |                |                 |                 |                 |       |
| SNL 3088     |                                |                |                 |                 |                 |       |
| SNL 3092     |                                |                |                 |                 |                 |       |
| SNL 3096     |                                |                |                 |                 |                 |       |
| SNL 30/500   |                                |                |                 |                 |                 |       |
| SNL 3134     | 2 100                          | 1 000          | 760             | 680             | 850             | 550   |
| SNL 3136     | 2 400                          | 1 150          | 850             | 760             | 950             | 620   |
| SNL 3138     | 2 700                          | 1 300          | 1 000           | 880             | 1 100           | 710   |
| SNL 3140     | 3 200                          | 1 600          | 1 100           | 1 000           | 1 300           | 840   |
| SNL 3144     | 4 000                          | 1 900          | 1 400           | 1 300           | 1 600           | 1 000 |
| SNL 3148     | 4 200                          | 2 000          | 1 500           | 1 400           | 1 700           | 1 100 |
| SNL 3152     | 4 700                          | 2 300          | 1 700           | 1 500           | 1 900           | 1 200 |
| SNL 3156     | 5 000                          | 2 400          | 1 800           | 1 600           | 2 000           | 1 300 |
| SNL 3160     | 6 000                          | 2 900          | 2 200           | 1 900           | 2 400           | 1 500 |
| SNL 3164     | 7 000                          | 3 400          | 2 500           | 2 200           | 2 800           | 1 800 |
| SNL 3168     |                                |                |                 |                 |                 |       |
| SNL 3172     |                                |                |                 |                 |                 |       |
| SNL 3176     |                                |                |                 |                 |                 |       |
| SNL 3180     |                                |                |                 |                 |                 |       |
| SNL 3184     |                                |                |                 |                 |                 |       |
| SNL 3188     |                                |                |                 |                 |                 |       |
| SNL 3192     |                                |                |                 |                 |                 |       |
| SNL 3196     |                                |                |                 |                 |                 |       |

For SNL 3076 to SNL 30/500 and SNL 3168 to SNL 3196, inclusive, please consult SKF

**Breaking loads for SNL plummer block housings**

Table 2

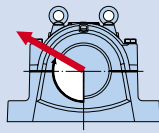

Q<sub>120°</sub>  
F<sub>120°</sub>

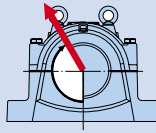

Q<sub>150°</sub>  
F<sub>150°</sub>

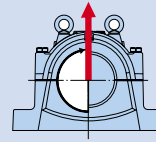

Q<sub>180°</sub>  
F<sub>180°</sub>

| Housing Size | Cap bolts                  |                   |                   | Maximum load for four bolts |                   |                   | Tightening torque | Designation to EN 24014 | Attachment bolts |                   |
|--------------|----------------------------|-------------------|-------------------|-----------------------------|-------------------|-------------------|-------------------|-------------------------|------------------|-------------------|
|              | Yield point for four bolts |                   |                   |                             |                   |                   |                   |                         | Size             | Tightening torque |
|              | Q <sub>120°</sub>          | Q <sub>150°</sub> | Q <sub>180°</sub> | F <sub>120°</sub>           | F <sub>150°</sub> | F <sub>180°</sub> |                   |                         |                  |                   |
|              | kN                         |                   |                   | kN                          |                   |                   | Nm                |                         |                  | Nm                |
| SNL 3036     | 1 800                      | 1 040             | 900               | 760                         | 440               | 380               | 350               | M 24×140                | M 24             | 750               |
| SNL 3038     | 1 800                      | 1 040             | 900               | 760                         | 440               | 380               | 350               | M 24×140                | M 24             | 750               |
| SNL 3040     | 1 800                      | 1 040             | 900               | 760                         | 440               | 380               | 350               | M 24×150                | M 24             | 750               |
| SNL 3044     | 1 800                      | 1 040             | 900               | 760                         | 440               | 380               | 350               | M 24×160                | M 30             | 1 400             |
| SNL 3048     | 1 800                      | 1 040             | 900               | 760                         | 440               | 380               | 350               | M 24×160                | M 30             | 1 400             |
| SNL 3052     | 2 860                      | 1 650             | 1 430             | 1 240                       | 720               | 620               | 400               | M 30×180                | M 30             | 1 400             |
| SNL 3056     | 2 860                      | 1 650             | 1 430             | 1 240                       | 720               | 620               | 400               | M 30×200                | M 36             | 2 400             |
| SNL 3060     | 2 860                      | 1 650             | 1 430             | 1 240                       | 720               | 620               | 400               | M 30×200                | M 36             | 2 400             |
| SNL 3064     | 2 860                      | 1 650             | 1 430             | 1 240                       | 720               | 620               | 400               | M 30×220                | M 36             | 2 400             |
| SNL 3068     | 2 860                      | 1 650             | 1 430             | 1 240                       | 720               | 620               | 400               | M 30×220                | M 36             | 2 400             |
| SNL 3072     | 2 860                      | 1 650             | 1 430             | 1 240                       | 720               | 620               | 400               | M 30×220                | M 36             | 2 400             |
| SNL 3076     |                            |                   |                   |                             |                   |                   |                   |                         |                  |                   |
| SNL 3080     |                            |                   |                   |                             |                   |                   |                   |                         |                  |                   |
| SNL 3084     |                            |                   |                   |                             |                   |                   |                   |                         |                  |                   |
| SNL 3088     |                            |                   |                   |                             |                   |                   |                   |                         |                  |                   |
| SNL 3092     |                            |                   |                   |                             |                   |                   |                   |                         |                  |                   |
| SNL 3096     |                            |                   |                   |                             |                   |                   |                   |                         |                  |                   |
| SNL 30/500   |                            |                   |                   |                             |                   |                   |                   |                         |                  |                   |
| SNL 3134     | 1 800                      | 1 040             | 900               | 760                         | 440               | 380               | 350               | M 24×140                | M 24             | 750               |
| SNL 3136     | 1 800                      | 1 040             | 900               | 760                         | 440               | 380               | 350               | M 24×140                | M 24             | 750               |
| SNL 3138     | 1 800                      | 1 040             | 900               | 760                         | 440               | 380               | 350               | M 24×150                | M 24             | 750               |
| SNL 3140     | 1 800                      | 1 040             | 900               | 760                         | 440               | 380               | 350               | M 24×160                | M 30             | 1 400             |
| SNL 3144     | 1 800                      | 1 040             | 900               | 760                         | 440               | 380               | 350               | M 24×160                | M 30             | 1 400             |
| SNL 3148     | 2 860                      | 1 650             | 1 430             | 1 240                       | 720               | 620               | 400               | M 30×180                | M 30             | 1 400             |
| SNL 3152     | 2 860                      | 1 650             | 1 430             | 1 240                       | 720               | 620               | 400               | M 30×200                | M 36             | 2 400             |
| SNL 3156     | 2 860                      | 1 650             | 1 430             | 1 240                       | 720               | 620               | 400               | M 30×200                | M 36             | 2 400             |
| SNL 3160     | 2 860                      | 1 650             | 1 430             | 1 240                       | 720               | 620               | 400               | M 30×220                | M 36             | 2 400             |
| SNL 3164     | 2 860                      | 1 650             | 1 430             | 1 240                       | 720               | 620               | 400               | M 30×220                | M 36             | 2 400             |
| SNL 3168     |                            |                   |                   |                             |                   |                   |                   |                         |                  |                   |
| SNL 3172     |                            |                   |                   |                             |                   |                   |                   |                         |                  |                   |
| SNL 3176     |                            |                   |                   |                             |                   |                   |                   |                         |                  |                   |
| SNL 3180     |                            |                   |                   |                             |                   |                   |                   |                         |                  |                   |
| SNL 3184     |                            |                   |                   |                             |                   |                   |                   |                         |                  |                   |
| SNL 3188     |                            |                   |                   |                             |                   |                   |                   |                         |                  |                   |
| SNL 3192     |                            |                   |                   |                             |                   |                   |                   |                         |                  |                   |
| SNL 3196     |                            |                   |                   |                             |                   |                   |                   |                         |                  |                   |

For SNL 3076 to SNL 30/500 and SNL 3168 to SNL 3196, inclusive, please consult SKF

**Load carrying ability of bolts**

SNL plummer block housings are supplied with cap bolts (to join cap and base) to strength class 8.8 as standard. The guideline values for the yield point Q for the cap bolts are given in **Table 2** for various load directions as well as the corresponding maximum radial loads F.

*Load carrying ability and tightening torques for cap bolts and attachment bolts*

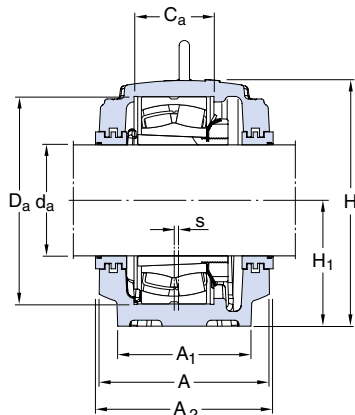

Labyrinth seals  
TS design

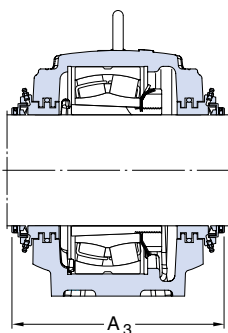

Taconite seals  
TNF design

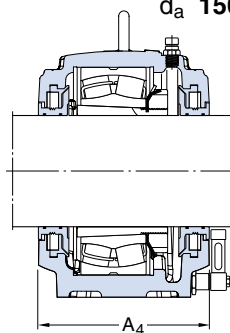

Oil seals  
TSD .. U design

| Shaft<br>d <sub>a</sub> | Housing<br>Dimensions |                |     |                |                |     |                |     |    |                |    |    | Mass<br>kg | Designations<br>Housing<br>complete with<br>two seals | Components<br>Housing only | Seal     | End cover  |          |
|-------------------------|-----------------------|----------------|-----|----------------|----------------|-----|----------------|-----|----|----------------|----|----|------------|---|----------------------------|----------|------------|----------|
|                         | A                     | A <sub>1</sub> | H   | H <sub>1</sub> | H <sub>2</sub> | J   | J <sub>1</sub> | L   | N  | N <sub>1</sub> | s  | G  |            |   |                            |          |            |          |
| mm                      | mm                    |                |     |                |                |     |                |     |    |                |    |    | kg         | –   |                            |          |            |          |
| 150                     | 230                   | 180            | 333 | 170            | 70             | 430 | 100            | 510 | 34 | 28             | 14 | 24 | 69,5       | SNL 3134 TS   | SNL 3134                   | TS 34    | ETS 34     |          |
|                         |                       |                |     |                |                |     |                |     |    |                |    |    |            |   | SNL 3134 TNF               | SNL 3134 | TNF 34     | ETS 34   |
|                         |                       |                |     |                |                |     |                |     |    |                |    |    |            |   | SNL 3134 TURT              | –        | TSD 3134 U | ETS 34 R |
|                         |                       |                |     |                |                |     |                |     |    |                |    |    |            |   | SNL 3134 TURA              | –        | TSD 3134 U | ETS 34 R |
| 160                     | 230                   | 180            | 333 | 170            | 70             | 430 | 100            | 510 | 34 | 28             | 14 | 24 | 69,5       | SNL 3036 TS   | SNL 3036                   | TS 36    | ETS 36     |          |
|                         |                       |                |     |                |                |     |                |     |    |                |    |    |            |   | SNL 3036 TNF               | SNL 3036 | TNF 36     | ETS 36   |
|                         |                       |                |     |                |                |     |                |     |    |                |    |    |            |   | SNL 3036 TURT              | –        | TSD 3036 U | ETS 36 R |
|                         |                       |                |     |                |                |     |                |     |    |                |    |    |            |   | SNL 3036 TURA              | –        | TSD 3036 U | ETS 36 R |
| 170                     | 240                   | 190            | 353 | 180            | 75             | 450 | 110            | 530 | 34 | 28             | 15 | 24 | 77,5       | SNL 3136 TS   | SNL 3136                   | TS 36    | ETS 36     |          |
|                         |                       |                |     |                |                |     |                |     |    |                |    |    |            |   | SNL 3136 TNF               | SNL 3136 | TNF 36     | ETS 36   |
|                         |                       |                |     |                |                |     |                |     |    |                |    |    |            |   | SNL 3136 TURT              | –        | TSD 3136 U | ETS 36 R |
|                         |                       |                |     |                |                |     |                |     |    |                |    |    |            |   | SNL 3136 TURA              | –        | TSD 3136 U | ETS 36 R |
| 180                     | 240                   | 190            | 353 | 180            | 75             | 450 | 110            | 530 | 34 | 28             | 15 | 24 | 77,5       | SNL 3038 TS   | SNL 3038                   | TS 38    | ETS 38     |          |
|                         |                       |                |     |                |                |     |                |     |    |                |    |    |            |   | SNL 3038 TNF               | SNL 3038 | TNF 38     | ETS 38   |
|                         |                       |                |     |                |                |     |                |     |    |                |    |    |            |   | SNL 3038 TURT              | –        | TSD 3038 U | ETS 38 R |
|                         |                       |                |     |                |                |     |                |     |    |                |    |    |            |   | SNL 3038 TURA              | –        | TSD 3038 U | ETS 38 R |
| 180                     | 260                   | 210            | 375 | 190            | 80             | 480 | 120            | 560 | 34 | 28             | 10 | 24 | 97,5       | SNL 3138 TS   | SNL 3138                   | TS 38    | ETS 38     |          |
|                         |                       |                |     |                |                |     |                |     |    |                |    |    |            |   | SNL 3138 TNF               | SNL 3138 | TNF 38     | ETS 38   |
|                         |                       |                |     |                |                |     |                |     |    |                |    |    |            |   | SNL 3138 TURT              | –        | TSD 3138 U | ETS 38 R |
|                         |                       |                |     |                |                |     |                |     |    |                |    |    |            |   | SNL 3138 TURA              | –        | TSD 3138 U | ETS 38 R |
| 180                     | 260                   | 210            | 375 | 190            | 80             | 480 | 120            | 560 | 34 | 28             | 10 | 24 | 97,5       | SNL 3040 TS   | SNL 3040                   | TS 40    | ETS 40     |          |
|                         |                       |                |     |                |                |     |                |     |    |                |    |    |            |   | SNL 3040 TNF               | SNL 3040 | TNF 40     | ETS 40   |
|                         |                       |                |     |                |                |     |                |     |    |                |    |    |            |   | SNL 3040 TURT              | –        | TSD 3040 U | ETS 40 R |
|                         |                       |                |     |                |                |     |                |     |    |                |    |    |            |   | SNL 3040 TURA              | –        | TSD 3040 U | ETS 40 R |
| 200                     | 280                   | 230            | 411 | 210            | 85             | 510 | 130            | 610 | 42 | 35             | 10 | 30 | 123        | SNL 3140 TS   | SNL 3140                   | TS 40    | ETS 40     |          |
|                         |                       |                |     |                |                |     |                |     |    |                |    |    |            |   | SNL 3140 TNF               | SNL 3140 | TNF 40     | ETS 40   |
|                         |                       |                |     |                |                |     |                |     |    |                |    |    |            |   | SNL 3140 TURT              | –        | TSD 3140 U | ETS 40 R |
|                         |                       |                |     |                |                |     |                |     |    |                |    |    |            |   | SNL 3140 TURA              | –        | TSD 3140 U | ETS 40 R |
| 200                     | 280                   | 230            | 411 | 210            | 85             | 510 | 130            | 610 | 42 | 35             | 10 | 30 | 123        | SNL 3044 TS   | SNL 3044                   | TS 44    | ETS 44     |          |
|                         |                       |                |     |                |                |     |                |     |    |                |    |    |            |   | SNL 3044 TNF               | SNL 3044 | TNF 44     | ETS 44   |
|                         |                       |                |     |                |                |     |                |     |    |                |    |    |            |   | SNL 3044 TURT              | –        | TSD 3044 U | ETS 44 R |
|                         |                       |                |     |                |                |     |                |     |    |                |    |    |            |   | SNL 3044 TURA              | –        | TSD 3044 U | ETS 44 R |
| 200                     | 290                   | 240            | 434 | 220            | 90             | 540 | 140            | 640 | 42 | 35             | 12 | 30 | 138        | SNL 3144 TS   | SNL 3144                   | TS 44    | ETS 44     |          |
|                         |                       |                |     |                |                |     |                |     |    |                |    |    |            |   | SNL 3144 TNF               | SNL 3144 | TNF 44     | ETS 44   |
|                         |                       |                |     |                |                |     |                |     |    |                |    |    |            |   | SNL 3144 TURT              | –        | TSD 3144 U | ETS 44 R |
|                         |                       |                |     |                |                |     |                |     |    |                |    |    |            |   | SNL 3144 TURA              | –        | TSD 3144 U | ETS 44 R |

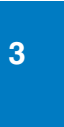
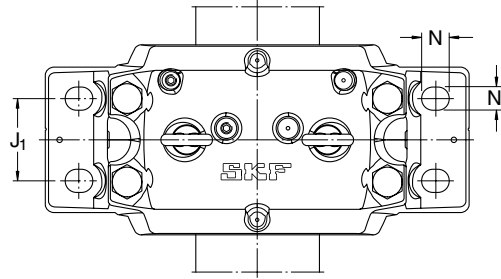
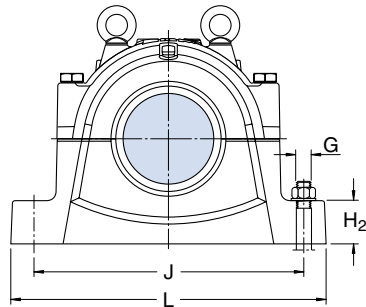

| Shaft<br>$d_a$ | Bearing seating |       | Width across seals |       |       | Eye bolts according to DIN 580 | Appropriate bearings and associated components |                          |                              |
|----------------|-----------------|-------|--------------------|-------|-------|--------------------------------|--|--------------------------|------------------------------|
|                | $C_a$           | $D_a$ | $A_2$              | $A_3$ | $A_4$ |                                | Spherical roller bearing                       | Adapter sleeve           | Locating rings               |
| mm             | mm              | mm    | mm                 | mm    | mm    | —                              | —  | —                        | —                            |
| 150            | 108             | 280   | 240                | 300   | 226   | M 16                           | 23134 CCK/W33                                  | H 3134                   | 2 FRB 10/280                 |
| 160            | 108             | 280   | 240                | 310   | 226   | M 16                           | 23036 CCK/W33<br>C 3036 K                      | H 3036<br>H 3036         | 2 FRB 17/280<br>2 FRB 17/280 |
|                | 116             | 300   | 250                | 315   | 235   | M 16                           | 23136 CCK/W33<br>C 3136 K                      | H 3136<br>H 3136 L       | 2 FRB 10/300<br>2 FRB 10/300 |
| 170            | 115             | 290   | 250                | 315   | 235   | M 16                           | 23038 CCK/W33<br>C 3038 K                      | H 3038<br>H 3038         | 4 FRB 10/290<br>4 FRB 10/290 |
|                | 124             | 320   | 270                | 335   | 255   | M 20                           | 23138 CCK/W33                                  | H 3138                   | 2 FRB 10/320                 |
| 180            | 122             | 310   | 270                | 335   | 255   | M 20                           | 23040 CCK/W33<br>C 3040 K                      | H 3040<br>H 3040         | 4 FRB 10/310<br>4 FRB 10/310 |
|                | 132             | 340   | 290                | 355   | 274   | M 20                           | 23140 CCK/W33<br>C 3140 K                      | H 3140<br>H 3140         | 2 FRB 10/340<br>2 FRB 10/340 |
| 200            | 130             | 340   | 290                | 360   | 274   | M 20                           | 23044 CCK/W33<br>C 3044 K                      | OH 3044 H<br>OH 3044 H   | 4 FRB 10/340<br>4 FRB 10/340 |
|                | 140             | 370   | 300                | 365   | 280   | M 20                           | 23144 CCK/W33<br>C 3144 K                      | OH 3144 H<br>OH 3144 HTL | 2 FRB 10/370<br>2 FRB 10/370 |

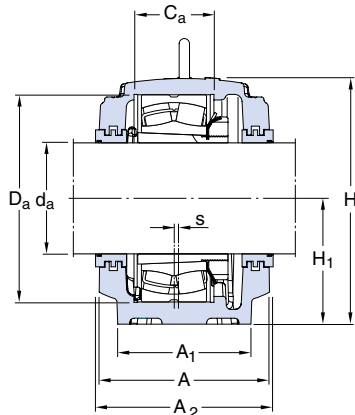

Labyrinth seals  
TS design

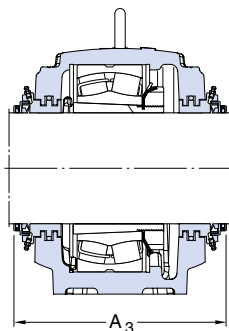

Taconite seals  
TNF design

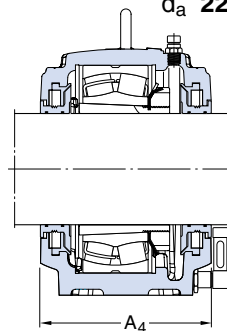

Oil seals  
TSD .. U design

| Shaft<br>$d_a$ | Housing<br>Dimensions |                |     |                |                |     |                |     |    |                |    |    | Mass<br>kg | Designations<br>Housing<br>complete with<br>two seals         | Components<br>Housing only     | Seal  | End cover                                |
|----------------|-----------------------|----------------|-----|----------------|----------------|-----|----------------|-----|----|----------------|----|----|------------|---|--------------------------------|---|--|
|                | A                     | A <sub>1</sub> | H   | H <sub>1</sub> | H <sub>2</sub> | J   | J <sub>1</sub> | L   | N  | N <sub>1</sub> | s  | G  |            |   |                                |   |  |
| mm             | mm                    |                |     |                |                |     |                |     |    |                |    |    | kg         | –   |                                |   |  |
| 220            | 290                   | 240            | 434 | 220            | 90             | 540 | 140            | 640 | 42 | 35             | 12 | 30 | 139        | SNL 3048 TS<br>SNL 3048 TNF<br>SNL 3048 TURT<br>SNL 3048 TURA | SNL 3048<br>SNL 3048<br>–<br>– | TS 48<br>TNF 48<br>TSD 3048 U<br>TSD 3048 U | ETS 48<br>ETS 48<br>ETS 48 R<br>ETS 48 R |
|                | 310                   | 260            | 474 | 240            | 95             | 600 | 150            | 700 | 42 | 35             | 12 | 30 | 187        | SNL 3148 TS<br>SNL 3148 TNF<br>SNL 3148 TURT<br>SNL 3148 TURA | SNL 3148<br>SNL 3148<br>–<br>– | TS 48<br>TNF 48<br>TSD 3148 U<br>TSD 3148 U | ETS 48<br>ETS 48<br>ETS 48 R<br>ETS 48 R |
| 240            | 310                   | 260            | 474 | 240            | 95             | 600 | 150            | 700 | 42 | 35             | 12 | 30 | 187        | SNL 3052 TS<br>SNL 3052 TNF<br>SNL 3052 TURT<br>SNL 3052 TURA | SNL 3052<br>SNL 3052<br>–<br>– | TS 52<br>TNF 52<br>TSD 3052 U<br>TSD 3052 U | ETS 52<br>ETS 52<br>ETS 52 R<br>ETS 52 R |
|                | 320                   | 280            | 516 | 260            | 100            | 650 | 160            | 770 | 50 | 42             | 13 | 36 | 221        | SNL 3152 TS<br>SNL 3152 TNF<br>SNL 3152 TURT<br>SNL 3152 TURA | SNL 3152<br>SNL 3152<br>–<br>– | TS 52<br>TNF 52<br>TSD 3152 U<br>TSD 3152 U | ETS 52<br>ETS 52<br>ETS 52 R<br>ETS 52 R |
| 260            | 320                   | 280            | 516 | 260            | 100            | 650 | 160            | 770 | 50 | 42             | 13 | 36 | 221        | SNL 3056 TS<br>SNL 3056 TNF<br>SNL 3056 TURT<br>SNL 3056 TURA | SNL 3056<br>SNL 3056<br>–<br>– | TS 56<br>TNF 56<br>TSD 3056 U<br>TSD 3056 U | ETS 56<br>ETS 56<br>ETS 56 R<br>ETS 56 R |
|                | 320                   | 280            | 551 | 280            | 105            | 670 | 160            | 790 | 50 | 42             | 16 | 36 | 252        | SNL 3156 TS<br>SNL 3156 TNF<br>SNL 3156 TURT<br>SNL 3156 TURA | SNL 3156<br>SNL 3156<br>–<br>– | TS 56<br>TNF 56<br>TSD 3156 U<br>TSD 3156 U | ETS 56<br>ETS 56<br>ETS 56 R<br>ETS 56 R |
| 280            | 320                   | 280            | 551 | 280            | 105            | 670 | 160            | 790 | 50 | 42             | 16 | 36 | 252        | SNL 3060 TS<br>SNL 3060 TNF<br>SNL 3060 TURT<br>SNL 3060 TURA | SNL 3060<br>SNL 3060<br>–<br>– | TS 60<br>TNF 60<br>TSD 3060 U<br>TSD 3060 U | ETS 60<br>ETS 60<br>ETS 60 R<br>ETS 60 R |
|                | 350                   | 310            | 591 | 300            | 110            | 710 | 190            | 830 | 50 | 42             | 22 | 36 | 301        | SNL 3160 TS<br>SNL 3160 TNF<br>SNL 3160 TURT<br>SNL 3160 TURA | SNL 3160<br>SNL 3160<br>–<br>– | TS 60<br>TNF 60<br>TSD 3160 U<br>TSD 3160 U | ETS 60<br>ETS 60<br>ETS 60 R<br>ETS 60 R |
| 300            | 350                   | 310            | 591 | 300            | 110            | 710 | 190            | 830 | 50 | 42             | 22 | 36 | 301        | SNL 3064 TS<br>SNL 3064 TNF<br>SNL 3064 TURT<br>SNL 3064 TURA | SNL 3064<br>SNL 3064<br>–<br>– | TS 64<br>TNF 64<br>TSD 3064 U<br>TSD 3064 U | ETS 64<br>ETS 64<br>ETS 64 R<br>ETS 64 R |
|                | 370                   | 330            | 631 | 320            | 115            | 750 | 200            | 880 | 50 | 42             | 23 | 36 | 339        | SNL 3164 TS<br>SNL 3164 TNF<br>SNL 3164 TURT<br>SNL 3164 TURA | SNL 3164<br>SNL 3164<br>–<br>– | TS 64<br>TNF 64<br>TSD 3164 U<br>TSD 3164 U | ETS 64<br>ETS 64<br>ETS 64 R<br>ETS 64 R |

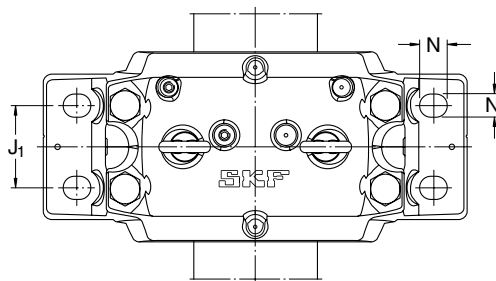
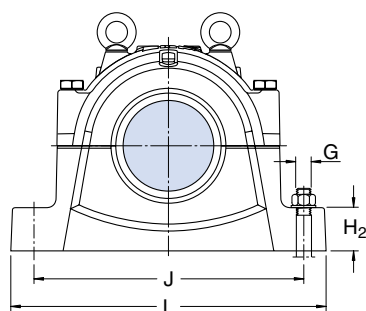

| Shaft<br>$d_a$ | Bearing seating |       | Width across seals |       |       | Eye bolts<br>according to<br>DIN 580 | Appropriate bearings and associated components |                          |                              |
|----------------|-----------------|-------|--------------------|-------|-------|--------------------------------------|--|--------------------------|------------------------------|
|                | $C_a$           | $D_a$ | $A_2$              | $A_3$ | $A_4$ |                                      | Spherical roller bearing<br>CARB bearing       | Adapter sleeve           | Locating rings               |
| mm             | mm              | mm    | mm                 | mm    | mm    | —                                    | —  | —                        | —                            |
| <b>220</b>     | 140             | 360   | 300                | 380   | 280   | M 20                                 | 23048 CCK/W33<br>C 3048 K                      | OH 3048 H<br>OH 3048 H   | 4 FRB 12/360<br>4 FRB 12/360 |
|                | 148             | 400   | 315                | 400   | 300   | M 24                                 | 23148 CCK/W33<br>C 3148 K                      | OH 3148 H<br>OH 3148 HTL | 2 FRB 10/400<br>2 FRB 10/400 |
| <b>240</b>     | 148             | 400   | 315                | 400   | 300   | M 24                                 | 23052 CCK/W33<br>C 3052 K                      | OH 3052 H<br>OH 3052 H   | 2 FRB 22/400<br>2 FRB 22/400 |
|                | 164             | 440   | 330                | 415   | 315   | M 24                                 | 23152 CCK/W33<br>C 3152 K                      | OH 3152 H<br>OH 3152 HTL | 2 FRB 10/440<br>2 FRB 10/440 |
| <b>260</b>     | 166             | 420   | 330                | 415   | 315   | M 24                                 | 23056 CCK/W33<br>C 3056 K                      | OH 3056 H<br>OH 3056 H   | 6 FRB 10/420<br>6 FRB 10/420 |
|                | 166             | 460   | 330                | 415   | 315   | M 24                                 | 23156 CCK/W33<br>C 3156 K                      | OH 3156 H<br>OH 3156 HTL | 2 FRB 10/460<br>2 FRB 10/460 |
| <b>280</b>     | 168             | 460   | 330                | 415   | 315   | M 24                                 | 23060 CCK/W33<br>C 3060 K                      | OH 3060 H<br>OH 3060 H   | 2 FRB 25/460<br>2 FRB 25/460 |
|                | 180             | 500   | 360                | 445   | 345   | M 30                                 | 23160 CCK/W33<br>C 3160 K                      | OH 3160 H<br>OH 3160 H   | 2 FRB 10/500<br>2 FRB 10/500 |
| <b>300</b>     | 181             | 480   | 360                | 445   | 345   | M 30                                 | 23064 CCK/W33<br>C 3064 K                      | OH 3064 H<br>OH 3064 H   | 6 FRB 10/480<br>6 FRB 10/480 |
|                | 196             | 540   | 380                | 465   | 365   | M 30                                 | 23164 CCK/W33<br>C 3164 K                      | OH 3164 H<br>OH 3164 H   | 2 FRB 10/540<br>2 FRB 10/540 |

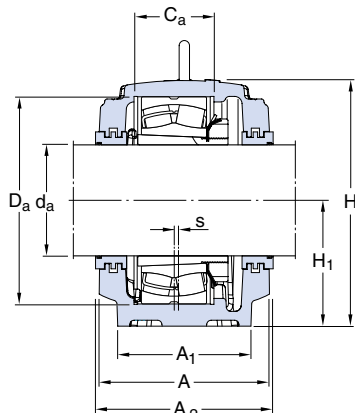

Labyrinth seals  
TS design

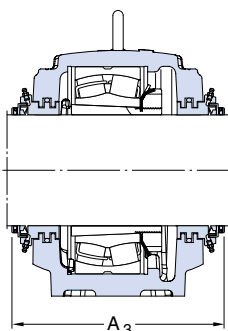

Taconite seals  
TNF design

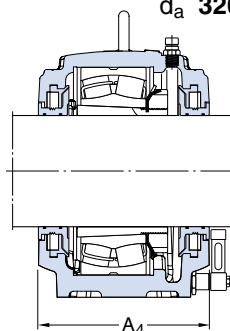

Oil seals  
TSD .. U design

| Shaft<br>$d_a$ | Housing<br>Dimensions |                |     |                |                |     |                |     |    |                |    |    | Mass | Designations<br>Housing<br>complete with<br>two seals | Components<br>Housing only | Seal       | End cover |
|----------------|-----------------------|----------------|-----|----------------|----------------|-----|----------------|-----|----|----------------|----|----|------|---|----------------------------|------------|-----------|
|                | A                     | A <sub>1</sub> | H   | H <sub>1</sub> | H <sub>2</sub> | J   | J <sub>1</sub> | L   | N  | N <sub>1</sub> | s  | G  |      |   |                            |            |           |
| mm             | mm                    |                |     |                |                |     |                |     |    |                |    |    | kg   | –   |                            |            |           |
| 320            | 370                   | 330            | 631 | 320            | 115            | 750 | 200            | 880 | 50 | 42             | 23 | 36 | 339  | SNL 3068 TS   | SNL 3068                   | TS 68      | ETS 68    |
|                |                       |                |     |                |                |     |                |     |    |                |    |    |      | SNL 3068 TNF  | SNL 3068                   | TNF 68     | ETS 68    |
|                |                       |                |     |                |                |     |                |     |    |                |    |    |      | SNL 3068 TURT   | –                          | TSD 3068 U | ETS 68 R  |
|                |                       |                |     |                |                |     |                |     |    |                |    |    |      | SNL 3068 TURA   | –                          | TSD 3068 U | ETS 68 R  |
| 340            |                       |                |     |                |                |     |                |     |    |                |    |    |      | SNL 3168 TS   | SNL 3168                   | TS 68      | ETS 68    |
|                |                       |                |     |                |                |     |                |     |    |                |    |    |      | SNL 3168 TNF  | SNL 3168                   | TNF 68     | ETS 68    |
|                |                       |                |     |                |                |     |                |     |    |                |    |    |      | SNL 3168 TURT   | –                          | TSD 3168 U | ETS 68 R  |
|                |                       |                |     |                |                |     |                |     |    |                |    |    |      | SNL 3168 TURA   | –                          | TSD 3168 U | ETS 68 R  |
| 340            |                       |                |     |                | 350            | 840 | 220            |     |    |                |    |    |      | SNL 3072 TNF  | SNL 3072                   | TS 72      | ETS 72    |
|                |                       |                |     |                |                |     |                |     |    |                |    |    |      | SNL 3072 TNF  | SNL 3072                   | TNF 72     | ETS 72    |
|                |                       |                |     |                |                |     |                |     |    |                |    |    |      | SNL 3072 TURT   | –                          | TSD 3072 U | ETS 72 R  |
|                |                       |                |     |                |                |     |                |     |    |                |    |    |      | SNL 3072 TURA   | –                          | TSD 3072 U | ETS 72 R  |
| 340            |                       |                |     |                |                |     |                |     |    |                |    |    |      | SNL 3172 TS   | SNL 3172                   | TS 72      | ETS 72    |
|                |                       |                |     |                |                |     |                |     |    |                |    |    |      | SNL 3172 TNF  | SNL 3172                   | TNF 72     | ETS 72    |
|                |                       |                |     |                |                |     |                |     |    |                |    |    |      | SNL 3172 TURT   | –                          | TSD 3172 U | ETS 72 R  |
|                |                       |                |     |                |                |     |                |     |    |                |    |    |      | SNL 3172 TURA   | –                          | TSD 3172 U | ETS 72 R  |
| 360            |                       |                |     | 340            | 810            | 220 |                |     |    |                |    |    |      | SNL 3076 TS   | SNL 3076                   | TS 76      | ETS 76    |
|                |                       |                |     |                |                |     |                |     |    |                |    |    |      | SNL 3076 TNF  | SNL 3076                   | TNF 76     | ETS 76    |
|                |                       |                |     |                |                |     |                |     |    |                |    |    |      | SNL 3076 TURT   | –                          | TSD 3076 U | ETS 76 R  |
|                |                       |                |     |                |                |     |                |     |    |                |    |    |      | SNL 3076 TURA   | –                          | TSD 3076 U | ETS 76 R  |
| 360            |                       |                |     | 360            | 870            | 220 |                |     |    |                |    |    |      | SNL 3176 TS   | SNL 3176                   | TS 76      | ETS 76    |
|                |                       |                |     |                |                |     |                |     |    |                |    |    |      | SNL 3176 TNF  | SNL 3176                   | TNF 76     | ETS 76    |
|                |                       |                |     |                |                |     |                |     |    |                |    |    |      | SNL 3176 TURT   | –                          | TSD 3176 U | ETS 76 R  |
|                |                       |                |     |                |                |     |                |     |    |                |    |    |      | SNL 3176 TURA   | –                          | TSD 3176 U | ETS 76 R  |
| 380            |                       |                |     | 350            | 840            | 220 |                |     |    |                |    |    |      | SNL 3080 TS   | SNL 3080                   | TS 80      | ETS 80    |
|                |                       |                |     |                |                |     |                |     |    |                |    |    |      | SNL 3080 TNF  | SNL 3080                   | TNF 80     | ETS 80    |
|                |                       |                |     |                |                |     |                |     |    |                |    |    |      | SNL 3080 TURT   | –                          | TSD 3080 U | ETS 80 R  |
|                |                       |                |     |                |                |     |                |     |    |                |    |    |      | SNL 3080 TURA   | –                          | TSD 3080 U | ETS 80 R  |
| 380            |                       |                |     | 380            | 950            | 240 |                |     |    |                |    |    |      | SNL 3180 TS   | SNL 3180                   | TS 80      | ETS 80    |
|                |                       |                |     |                |                |     |                |     |    |                |    |    |      | SNL 3180 TNF  | SNL 3180                   | TNF 80     | ETS 80    |
|                |                       |                |     |                |                |     |                |     |    |                |    |    |      | SNL 3180 TURT   | –                          | TSD 3180 U | ETS 80 R  |
|                |                       |                |     |                |                |     |                |     |    |                |    |    |      | SNL 3180 TURA   | –                          | TSD 3180 U | ETS 80 R  |
| 400            |                       |                |     | 360            | 870            | 220 |                |     |    |                |    |    |      | SNL 3084 TS   | SNL 3084                   | TS 84      | ETS 84    |
|                |                       |                |     |                |                |     |                |     |    |                |    |    |      | SNL 3084 TNF  | SNL 3084                   | TNF 84     | ETS 84    |
|                |                       |                |     |                |                |     |                |     |    |                |    |    |      | SNL 3084 TURT   | –                          | TSD 3084 U | ETS 84 R  |
|                |                       |                |     |                |                |     |                |     |    |                |    |    |      | SNL 3084 TURA   | –                          | TSD 3084 U | ETS 84 R  |
| 400            |                       |                |     | 410            | 1 000          | 260 |                |     |    |                |    |    |      | SNL 3184 TS   | SNL 3184                   | TS 84      | ETS 84    |
|                |                       |                |     |                |                |     |                |     |    |                |    |    |      | SNL 3184 TNF  | SNL 3184                   | TNF 84     | ETS 84    |
|                |                       |                |     |                |                |     |                |     |    |                |    |    |      | SNL 3184 TURT   | –                          | TSD 3184 U | ETS 84 R  |
|                |                       |                |     |                |                |     |                |     |    |                |    |    |      | SNL 3184 TURA   | –                          | TSD 3184 U | ETS 84 R  |

For missing dimensions and availability please consult SKF

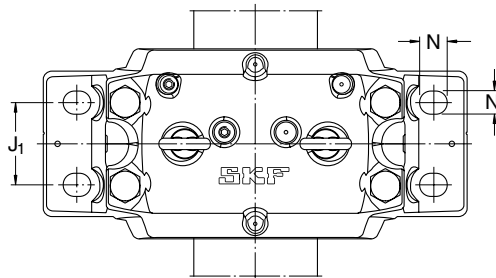
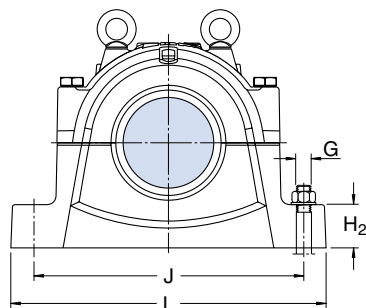

| Shaft<br>$d_a$ | Bearing seating |                | Width across seals |       |       | Eye bolts<br>according to<br>DIN 580 | Appropriate bearings and associated components |                |                |
|----------------|-----------------|----------------|--------------------|-------|-------|--------------------------------------|--|----------------|----------------|
|                | $C_a$           | $D_a$          | $A_2$              | $A_3$ | $A_4$ |                                      | Spherical roller bearing                       | Adapter sleeve | Locating rings |
| mm             | mm              | mm             | mm                 | mm    | mm    | —                                    | —  | —              | —              |
| 320            | 197             | 520            | 380                | 465   | 365   | M 30                                 | 23068 CCK/W33                                  | OH 3068 H      | 4 FRB 16/520   |
|                |                 |                |                    |       |       |                                      | C 3068 K                                       | OH 3068 H      | 4 FRB 16/520   |
| 340            | 198             | 540            | 380                | 465   | 365   | M 30                                 | 23168 CCK/W33                                  | OH 3168 H      | 4 FRB 16/540   |
|                |                 |                |                    |       |       |                                      | C 3168 K                                       | OH 3168 H      | 4 FRB 16/540   |
| 360            | 560             | 600            | 380                | 465   | 365   | M 30                                 | 23072 CCK/W33                                  | OH 3072 H      | 4 FRB 16/540   |
|                |                 | 23172 CACK/W33 |                    |       |       |                                      | OH 3172 H                                      | 4 FRB 16/540   |                |
| 380            | 600             | 620            | 380                | 465   | 365   | M 30                                 | 23172 CACK/W33                                 | OH 3172 H      | 4 FRB 16/540   |
|                |                 | 23176 CAK/W33  |                    |       |       |                                      | OH 3176 H                                      | 4 FRB 16/540   |                |
| 400            | 620             | 600            | 380                | 465   | 365   | M 30                                 | 23076 CCK/W33                                  | OH 3076 H      | 4 FRB 16/540   |
|                |                 | 23176 CAK/W33  |                    |       |       |                                      | OH 3176 H                                      | 4 FRB 16/540   |                |
| 400            | 620             | 650            | 380                | 465   | 365   | M 30                                 | 23080 CACK/W33                                 | OH 3080 H      | 4 FRB 16/540   |
|                |                 | C 3080 K       |                    |       |       |                                      | OH 3080 H                                      | 4 FRB 16/540   |                |
| 400            | 620             | 650            | 380                | 465   | 365   | M 30                                 | 23180 CAK/W33                                  | OH 3180 H      | 4 FRB 16/540   |
|                |                 | C 3180 K       |                    |       |       |                                      | OH 3180 H                                      | 4 FRB 16/540   |                |
| 400            | 620             | 700            | 380                | 465   | 365   | M 30                                 | 23084 CAK/W33                                  | OH 3084 H      | 4 FRB 16/540   |
|                |                 | 23184 CK/W33   |                    |       |       |                                      | OH 3184 H                                      | 4 FRB 16/540   |                |

For missing dimensions and availability please consult SKF

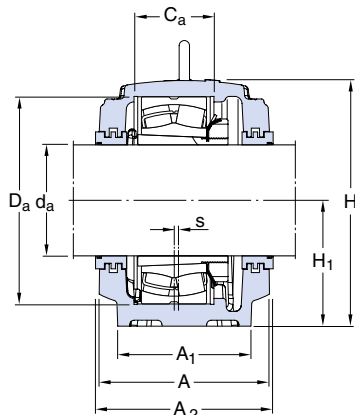

Labyrinth seals  
TS design

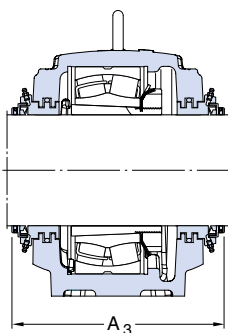

Taconite seals  
TNF design

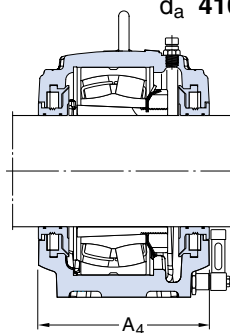

Oil seals  
TSD .. U design

| Shaft<br>d <sub>a</sub> | Housing<br>Dimensions |                |     |                |                |   |                |   |   |                | Mass<br>kg | Designations<br>Housing<br>complete with<br>two seals | Components |                       | End cover  |              |           |
|-------------------------|-----------------------|----------------|-----|----------------|----------------|---|----------------|---|---|----------------|------------|---|------------|-----------------------|------------|--------------|-----------|
|                         | A                     | A <sub>1</sub> | H   | H <sub>1</sub> | H <sub>2</sub> | J | J <sub>1</sub> | L | N | N <sub>1</sub> |            |   | s          | G                     |            | Housing only | Seal      |
| mm                      | mm                    |                |     |                |                |   |                |   |   |                | kg         | –   |            |                       |            |              |           |
| 410                     |                       |                | 380 |                | 950            |   | 240            |   |   |                |            |   |            | <b>SNL 3088 TS</b>    | SNL 3088   | TS 88        | ETS 88    |
|                         |                       |                |     |                |                |   |                |   |   |                |            |   |            | <b>SNL 3088 TNF</b>   | SNL 3088   | TNF 88       | ETS 88    |
|                         |                       |                |     |                |                |   |                |   |   |                |            |   |            | –                     | –          | TSD 3088 U   | ETS 88 R  |
|                         |                       |                |     |                |                |   |                |   |   |                |            |   |            | –                     | –          | TSD 3088 U   | ETS 88 R  |
| 410                     |                       |                | 420 |                | 1 030          |   | 260            |   |   |                |            |   |            | <b>SNL 3188 TS</b>    | SNL 3188   | TS 88        | ETS 88    |
|                         |                       |                |     |                |                |   |                |   |   |                |            |   |            | <b>SNL 3188 TNF</b>   | SNL 3188   | TNF 88       | ETS 88    |
|                         |                       |                |     |                |                |   |                |   |   |                |            |   |            | –                     | –          | TSD 3188 U   | ETS 88 R  |
|                         |                       |                |     |                |                |   |                |   |   |                |            |   |            | –                     | –          | TSD 3188 U   | ETS 88 R  |
| 430                     |                       |                | 420 |                | 1 030          |   | 260            |   |   |                |            |   |            | <b>SNL 3092 TS</b>    | SNL 3092   | TS 92        | ETS 92    |
|                         |                       |                |     |                |                |   |                |   |   |                |            |   |            | <b>SNL 3092 TNF</b>   | SNL 3092   | TNF 92       | ETS 92    |
|                         |                       |                |     |                |                |   |                |   |   |                |            |   |            | –                     | –          | TSD 3092 U   | ETS 92 R  |
|                         |                       |                |     |                |                |   |                |   |   |                |            |   |            | –                     | –          | TSD 3092 U   | ETS 92 R  |
| 430                     |                       |                | 440 |                | 1 070          |   | 260            |   |   |                |            |   |            | <b>SNL 3192 TS</b>    | SNL 3192   | TS 92        | ETS 92    |
|                         |                       |                |     |                |                |   |                |   |   |                |            |   |            | <b>SNL 3192 TNF</b>   | SNL 3192   | TNF 92       | ETS 92    |
|                         |                       |                |     |                |                |   |                |   |   |                |            |   |            | –                     | –          | TSD 3192 U   | ETS 92 R  |
|                         |                       |                |     |                |                |   |                |   |   |                |            |   |            | –                     | –          | TSD 3192 U   | ETS 92 R  |
| 450                     |                       |                | 410 |                | 1 000          |   | 260            |   |   |                |            |   |            | <b>SNL 3096 TS</b>    | SNL 3096   | TS 96        | ETS 96    |
|                         |                       |                |     |                |                |   |                |   |   |                |            |   |            | <b>SNL 3096 TNF</b>   | SNL 3096   | TNF 96       | ETS 96    |
|                         |                       |                |     |                |                |   |                |   |   |                |            |   |            | –                     | –          | TSD 3096 U   | ETS 96 R  |
|                         |                       |                |     |                |                |   |                |   |   |                |            |   |            | –                     | –          | TSD 3096 U   | ETS 96 R  |
| 450                     |                       |                | 460 |                | 1 110          |   | 260            |   |   |                |            |   |            | <b>SNL 3196 TS</b>    | SNL 3196   | TS 96        | ETS 96    |
|                         |                       |                |     |                |                |   |                |   |   |                |            |   |            | <b>SNL 3196 TNF</b>   | SNL 3196   | TNF 96       | ETS 96    |
|                         |                       |                |     |                |                |   |                |   |   |                |            |   |            | –                     | –          | TSD 3196 U   | ETS 96 R  |
|                         |                       |                |     |                |                |   |                |   |   |                |            |   |            | –                     | –          | TSD 3196 U   | ETS 96 R  |
| 470                     |                       |                | 420 |                | 1 030          |   | 260            |   |   |                |            |   |            | <b>SNL 30/500 TS</b>  | SNL 30/500 | TS 500       | ETS 500   |
|                         |                       |                |     |                |                |   |                |   |   |                |            |   |            | <b>SNL 30/500 TNF</b> | SNL 30/500 | TNF 500      | ETS 500   |
|                         |                       |                |     |                |                |   |                |   |   |                |            |   |            | –                     | –          | TSD 30/500 U | ETS 500 R |
|                         |                       |                |     |                |                |   |                |   |   |                |            |   |            | –                     | –          | TSD 30/500 U | ETS 500 R |

For missing dimensions and availability please consult SKF

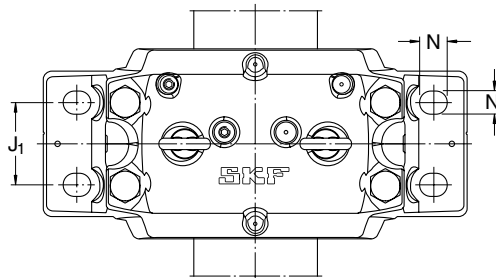
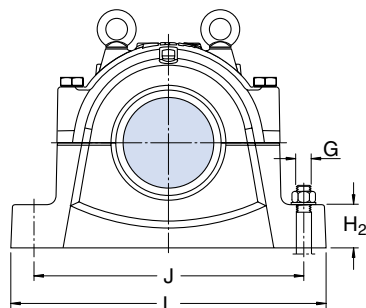

| Shaft<br>$d_a$ | Bearing seating |       | Width across seals |       |       | Eye bolts according to DIN 580 | Appropriate bearings and associated components |                |                |
|----------------|-----------------|-------|--------------------|-------|-------|--------------------------------|--|----------------|----------------|
|                | $C_a$           | $D_a$ | $A_2$              | $A_3$ | $A_4$ |                                | Spherical roller bearing                       | Adapter sleeve | Locating rings |
| mm             | mm              | mm    | mm                 |       |       | —                              | —  |                |                |
| 410            |                 | 650   |                    |       |       |                                | 23088 CAK/W33                                  |                | OH 3088 H      |
|                |                 | 720   |                    |       |       |                                | 23188 CAK/W33                                  |                | OH 3188 H      |
| 430            |                 | 680   |                    |       |       |                                | 23092 CAK/W33                                  |                | OH 3092 H      |
|                |                 | 760   |                    |       |       |                                | 23192 CAK/W33                                  |                | OH 3192 H      |
| 450            |                 | 700   |                    |       |       |                                | 23096 CAK/W33                                  |                | OH 3096 H      |
|                |                 | 790   |                    |       |       |                                | 23196 CAK/W33                                  |                | OH 3196 H      |
| 470            |                 | 720   |                    |       |       |                                | 230/500 CAK/W33                                |                | OH 30/500 H    |

For missing dimensions and availability please consult SKF

Large SNL plummer block housings  
for bearings with cylindrical bore  
d<sub>a</sub> 170–260 mm

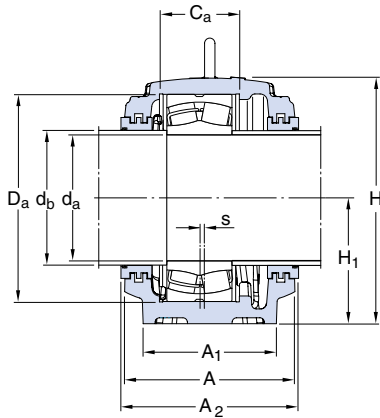

Labyrinth seals  
TS design

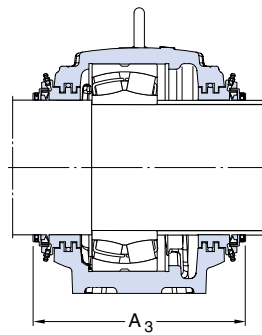

Taconite seals  
TNF design

| Shaft<br>d <sub>a</sub> | Housing<br>Dimensions |                |     |                |                |     |                |     |    |                |    |    |      | Mass<br>kg                                  | Designations<br>Housing<br>complete with<br>two seals | Components<br>Housing only | Seal             | End cover |
|-------------------------|-----------------------|----------------|-----|----------------|----------------|-----|----------------|-----|----|----------------|----|----|------|---|---|----------------------------|------------------|-----------|
|                         | A                     | A <sub>1</sub> | H   | H <sub>1</sub> | H <sub>2</sub> | J   | J <sub>1</sub> | L   | N  | N <sub>1</sub> | s  | G  |      |   |   |                            |                  |           |
| mm                      | mm                    |                |     |                |                |     |                |     |    |                |    |    |      | kg  | –   |                            |                  |           |
| 170                     | 230                   | 180            | 333 | 170            | 70             | 430 | 100            | 510 | 34 | 28             | 14 | 24 | 69,5 | <b>SNL 3134 GTS</b><br><b>SNL 3134 GTNF</b> | SNL 3134 G<br>SNL 3134 G                              | TS 40<br>TNF 40            | ETS 40<br>ETS 40 |           |
|                         | 230                   | 180            | 333 | 170            | 70             | 430 | 100            | 510 | 34 | 28             | 14 | 24 | 69,5 | <b>SNL 3036 GTS</b><br><b>SNL 3036 GTNF</b> | SNL 3036 G<br>SNL 3036 G                              | TS 44<br>TNF 44            | ETS 44<br>ETS 44 |           |
| 180                     | 240                   | 190            | 353 | 180            | 75             | 450 | 110            | 530 | 34 | 28             | 15 | 24 | 77,5 | <b>SNL 3136 GTS</b><br><b>SNL 3136 GTNF</b> | SNL 3136 G<br>SNL 3136 G                              | TS 44<br>TNF 44            | ETS 44<br>ETS 44 |           |
|                         | 240                   | 190            | 353 | 180            | 75             | 450 | 110            | 530 | 34 | 28             | 15 | 24 | 77,5 | <b>SNL 3038 GTS</b><br><b>SNL 3038 GTNF</b> | SNL 3038 G<br>SNL 3038 G                              | TS 44<br>TNF 44            | ETS 44<br>ETS 44 |           |
| 190                     | 260                   | 210            | 375 | 190            | 80             | 480 | 120            | 560 | 34 | 28             | 10 | 24 | 97,5 | <b>SNL 3138 GTS</b><br><b>SNL 3138 GTNF</b> | SNL 3138 G<br>SNL 3138 G                              | TS 44<br>TNF 44            | ETS 44<br>ETS 44 |           |
|                         | 260                   | 210            | 375 | 190            | 80             | 480 | 120            | 560 | 34 | 28             | 10 | 24 | 97,5 | <b>SNL 3040 GTS</b><br><b>SNL 3040 GTNF</b> | SNL 3040 G<br>SNL 3040 G                              | TS 48<br>TNF 48            | ETS 48<br>ETS 48 |           |
| 200                     | 280                   | 230            | 411 | 210            | 85             | 510 | 130            | 610 | 42 | 35             | 10 | 30 | 123  | <b>SNL 3140 GTS</b><br><b>SNL 3140 GTNF</b> | SNL 3140 G<br>SNL 3140 G                              | TS 48<br>TNF 48            | ETS 48<br>ETS 48 |           |
|                         | 280                   | 230            | 411 | 210            | 85             | 510 | 130            | 610 | 42 | 35             | 10 | 30 | 123  | <b>SNL 3044 GTS</b><br><b>SNL 3044 GTNF</b> | SNL 3044 G<br>SNL 3044 G                              | TS 52<br>TNF 52            | ETS 52<br>ETS 52 |           |
| 220                     | 290                   | 240            | 434 | 220            | 90             | 540 | 140            | 640 | 42 | 35             | 12 | 30 | 138  | <b>SNL 3144 GTS</b><br><b>SNL 3144 GTNF</b> | SNL 3144 G<br>SNL 3144 G                              | TS 52<br>TNF 52            | ETS 52<br>ETS 52 |           |
|                         | 290                   | 240            | 434 | 220            | 90             | 540 | 140            | 640 | 42 | 35             | 12 | 30 | 138  | <b>SNL 3048 GTS</b><br><b>SNL 3048 GTNF</b> | SNL 3048 G<br>SNL 3048 G                              | TS 56<br>TNF 56            | ETS 56<br>ETS 56 |           |
| 240                     | 310                   | 260            | 474 | 240            | 95             | 600 | 150            | 700 | 42 | 35             | 12 | 30 | 187  | <b>SNL 3148 GTS</b><br><b>SNL 3148 GTNF</b> | SNL 3148 G<br>SNL 3148 G                              | TS 56<br>TNF 56            | ETS 56<br>ETS 56 |           |
|                         | 310                   | 260            | 474 | 240            | 95             | 600 | 150            | 700 | 42 | 35             | 12 | 30 | 187  | <b>SNL 3052 GTS</b><br><b>SNL 3052 GTNF</b> | SNL 3052 G<br>SNL 3052 G                              | TS 60<br>TNF 60            | ETS 60<br>ETS 60 |           |
| 260                     | 320                   | 280            | 516 | 260            | 100            | 650 | 160            | 770 | 50 | 42             | 13 | 36 | 221  | <b>SNL 3152 GTS</b><br><b>SNL 3152 GTNF</b> | SNL 3152 G<br>SNL 3152 G                              | TS 60<br>TNF 60            | ETS 60<br>ETS 60 |           |

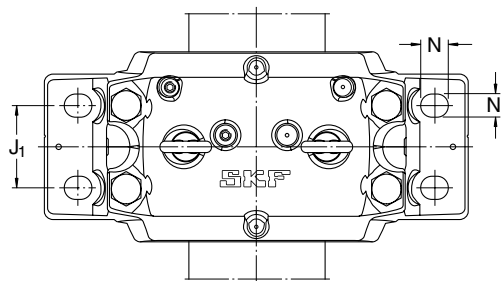
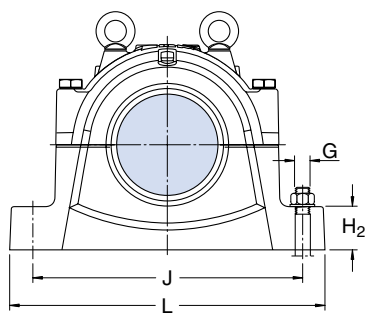

| Shaft          |                | Bearing seating |                | Width across seals |                | Eye bolts according to DIN 580 | Appropriate bearings and associated components |   |
|----------------|----------------|-----------------|----------------|--------------------|----------------|--------------------------------|--|---|
| d <sub>a</sub> | d <sub>b</sub> | C <sub>a</sub>  | D <sub>a</sub> | A <sub>2</sub>     | A <sub>3</sub> |                                | Spherical roller bearing                       | Locating rings                                |
| mm             | mm             | mm              | mm             | mm                 | mm             | —                              | —  | —   |
| 170            | 180            | 108             | 280            | 240                | 300            | M 16                           | 23134 CC/W33                                   | 2 FRB 10/280                                  |
| 180            | 200            | 108             | 280            | 240                | 310            | M 16                           | 23036 CC/W33<br>24036 CC/W33<br>C 3036         | 2 FRB 17/280<br>2 FRB 4/280<br>2 FRB 17/280   |
|                |                | 116             | 300            | 250                | 315            | M 16                           | 23136 CC/W33<br>C 3136                         | 2 FRB 10/300<br>2 FRB 10/300                  |
| 190            | 200            | 115             | 290            | 250                | 315            | M 16                           | 23038 CC/W33<br>24038 CC/W33<br>C 3038         | 4 FRB 10/290<br>2 FRB 7,5/290<br>4 FRB 10/290 |
|                |                | 124             | 320            | 270                | 335            | M 20                           | 23138 CC/W33                                   | 2 FRB 10/320                                  |
| 200            | 220            | 122             | 310            | 270                | 335            | M20                            | 23040 CC/W33<br>24040 CC/W33<br>C 3040         | 4 FRB 10/310<br>2 FRB 6,5/310<br>4 FRB 10/310 |
|                |                | 132             | 340            | 290                | 355            | M 20                           | 23140 CC/W33<br>C 3140                         | 2 FRB 10/340<br>2 FRB 10/340                  |
| 220            | 240            | 130             | 340            | 290                | 360            | M 20                           | 23044 CC/W33<br>24044 CC/W33<br>C 3044         | 4 FRB 10/340<br>2 FRB 6/340<br>4 FRB 10/340   |
|                |                | 140             | 370            | 300                | 365            | M 20                           | 23144 CC/W33<br>C 3144                         | 2 FRB 10/370<br>2 FRB 10/370                  |
| 240            | 260            | 140             | 360            | 300                | 380            | M 20                           | 23048 CC/W33<br>24048 CC/W33<br>C 3048         | 4 FRB 12/360<br>2 FRB 11/360<br>4 FRB 12/360  |
|                |                | 148             | 400            | 315                | 400            | M 24                           | 23148 CC/W33<br>C 3148                         | 2 FRB 10/400<br>2 FRB 10/400                  |
| 260            | 280            | 148             | 400            | 315                | 400            | M 24                           | 23052 CC/W33<br>24052 CC/W33<br>C 3052         | 2 FRB 22/400<br>2 FRB 4/400<br>2 FRB 22/400   |
|                |                | 164             | 440            | 330                | 415            | M 24                           | 23152 CC/W33<br>C 3152                         | 2 FRB 10/440<br>2 FRB 10/440                  |

Large SNL plummer block housings  
for bearings with cylindrical bore  
d<sub>a</sub> 280–400 mm

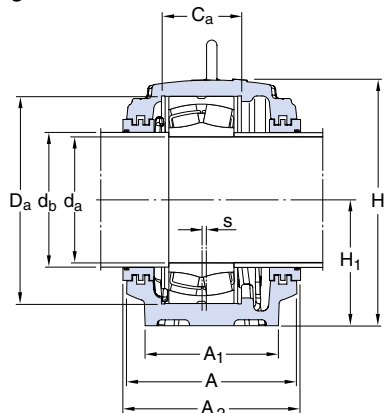

Labyrinth seals  
TS design

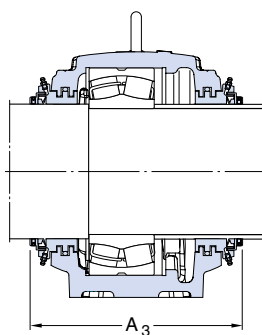

Taconite seals  
TNF design

| Shaft<br>d <sub>a</sub> | Housing<br>Dimensions |                |     |                |                |     |                |     |    |                |    |    |     | Mass<br>kg                                  | Designations<br>Housing<br>complete with<br>two seals | Components<br>Housing only | Seal             | End cover |
|-------------------------|-----------------------|----------------|-----|----------------|----------------|-----|----------------|-----|----|----------------|----|----|-----|---|---|----------------------------|------------------|-----------|
|                         | A                     | A <sub>1</sub> | H   | H <sub>1</sub> | H <sub>2</sub> | J   | J <sub>1</sub> | L   | N  | N <sub>1</sub> | s  | G  |     |   |   |                            |                  |           |
| mm                      | mm                    |                |     |                |                |     |                |     |    |                |    |    |     | kg  | –   |                            |                  |           |
| 280                     | 320                   | 280            | 516 | 260            | 100            | 650 | 160            | 770 | 50 | 42             | 13 | 36 | 221 | <b>SNL 3056 GTS</b><br><b>SNL 3056 GTNF</b> | SNL 3056 G<br>SNL 3056 G                              | TS 64<br>TNF 64            | ETS 64<br>ETS 64 |           |
|                         | 320                   | 280            | 551 | 280            | 105            | 670 | 160            | 790 | 50 | 42             | 16 | 36 | 252 | <b>SNL 3156 GTS</b><br><b>SNL 3156 GTNF</b> | SNL 3156 G<br>SNL 3156 G                              | TS 64<br>TNF 64            | ETS 64<br>ETS 64 |           |
| 300                     | 320                   | 280            | 551 | 280            | 105            | 670 | 160            | 790 | 50 | 42             | 16 | 36 | 252 | <b>SNL 3060 GTS</b><br><b>SNL 3060 GTNF</b> | SNL 3060 G<br>SNL 3060 G                              | TS 68<br>TNF 68            | ETS 68<br>ETS 68 |           |
|                         | 350                   | 310            | 591 | 300            | 110            | 710 | 190            | 830 | 50 | 42             | 22 | 36 | 301 | <b>SNL 3160 GTS</b><br><b>SNL 3160 GTNF</b> | SNL 3160 G<br>SNL 3160 G                              | TS 68<br>TNF 68            | ETS 68<br>ETS 68 |           |
| 320                     | 350                   | 310            | 591 | 300            | 110            | 710 | 190            | 830 | 50 | 42             | 22 | 36 | 301 | <b>SNL 3064 GTS</b><br><b>SNL 3064 GTNF</b> | SNL 3064 G<br>SNL 3064 G                              | TS 72<br>TNF 72            | ETS 72<br>ETS 72 |           |
|                         | 370                   | 330            | 631 | 320            | 115            | 750 | 200            | 880 | 50 | 42             | 23 | 36 | 339 | <b>SNL 3164 GTS</b><br><b>SNL 3164 GTNF</b> | SNL 3164 G<br>SNL 3164 G                              | TS 72<br>TNF 72            | ETS 72<br>ETS 72 |           |
| 340                     | 370                   | 330            | 631 | 320            | 115            | 750 | 200            | 880 | 50 | 42             | 23 | 36 | 339 | <b>SNL 3068 GTS</b><br><b>SNL 3068 GTNF</b> | SNL 3068 G<br>SNL 3068 G                              | TS 76<br>TNF 76            | ETS 76<br>ETS 76 |           |
|                         |                       |                |     |                |                |     |                |     |    |                |    |    |     | <b>SNL 3168 GTS</b><br><b>SNL 3168 GTNF</b> | SNL 3168 G<br>SNL 3168 G                              |                            |                  |           |
| 360                     | 370                   | 330            | 631 | 320            | 115            | 750 | 200            | 880 | 50 | 42             | 23 | 36 | 339 | <b>SNL 3072 GTS</b><br><b>SNL 3072 GTNF</b> | SNL 3072 G<br>SNL 3072 G                              | TS 80<br>TNF 80            | ETS 80<br>ETS 80 |           |
|                         |                       |                |     | 350            |                |     |                |     |    |                |    |    |     | <b>SNL 3172 GTS</b><br><b>SNL 3172 GTNF</b> | SNL 3172 G<br>SNL 3172 G                              |                            |                  |           |
| 380                     |                       |                |     | 340            |                |     |                |     |    |                |    |    |     | <b>SNL 3076 GTS</b><br><b>SNL 3076 GTNF</b> | SNL 3076 G<br>SNL 3076 G                              |                            |                  |           |
|                         |                       |                |     | 360            |                |     |                |     |    |                |    |    |     | <b>SNL 3176 GTS</b><br><b>SNL 3176 GTNF</b> | SNL 3176 G<br>SNL 3176 G                              |                            |                  |           |
| 400                     |                       |                |     | 350            |                |     |                |     |    |                |    |    |     | <b>SNL 3080 GTS</b><br><b>SNL 3080 GTNF</b> | SNL 3080 G<br>SNL 3080 G                              |                            |                  |           |
|                         |                       |                |     | 380            |                |     |                |     |    |                |    |    |     | <b>SNL 3180 GTS</b><br><b>SNL 3180 GTNF</b> | SNL 3180 G<br>SNL 3180 G                              |                            |                  |           |

For missing dimensions and availability please consult SKF

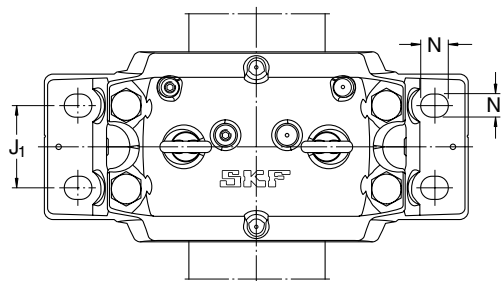
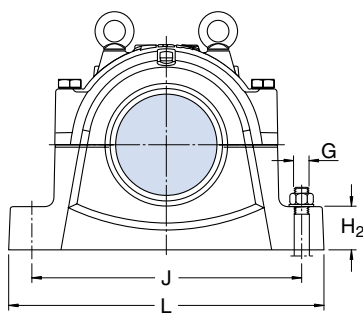

| Shaft          |                | Bearing seating |                | Width across seals |                | Eye bolts according to DIN 580 | Appropriate bearings and associated components                   |  |
|----------------|----------------|-----------------|----------------|--------------------|----------------|--------------------------------|--|--|
| d <sub>a</sub> | d <sub>b</sub> | C <sub>a</sub>  | D <sub>a</sub> | A <sub>2</sub>     | A <sub>3</sub> |                                | Spherical roller bearing   | Locating rings                                 |
| mm             | mm             | mm              | mm             | mm                 | mm             | —                              | —  | —  |
| 280            | 300            | 166             | 420            | 330                | 415            | M 24                           | 23056 CC/W33<br>24056 CC/W33<br>C 3056                           | 6 FRB 10/420<br>2 FRB 13/420<br>6 FRB 10/420   |
|                |                | 166             | 460            | 330                | 415            | M 24                           | 23156 CC/W33<br>C 3156   | 2 FRB 10/460<br>2 FRB 10/460                   |
| 300            | 320            | 168             | 460            | 330                | 415            | M 24                           | 23060 CC/W33<br>24060 CC/W33<br>C 3060                           | 2 FRB 25/460<br>2 FRB 4/460<br>2 FRB 25/460    |
|                |                | 180             | 500            | 360                | 445            | M 30                           | 23160 CC/W33<br>C 3160   | 2 FRB 10/500<br>2 FRB 10/500                   |
| 320            | 340            | 181             | 480            | 360                | 445            | M 30                           | 23064 CC/W33<br>24064 CC/W33<br>C 3064                           | 6 FRB 10/480<br>2 FRB 10,5/480<br>6 FRB 10/480 |
|                |                | 196             | 540            | 380                | 465            | M 30                           | 23164 CC/W33<br>C 3164   | 2 FRB 10/540<br>2 FRB 10/540                   |
| 340            | 360            | 197             | 520            | 380                | 465            | M 30                           | 23068 CC/W33<br>24068 CC/W33<br>C 3068<br>23168 CC/W33<br>C 3168 | 4 FRB 16/520<br>2 FRB 8,5/520<br>4 FRB 16/520  |
| 360            | 380            | 198             | 540            | 380                | 465            | M 30                           | 23072 CC/W33<br>24072 CC/W33                                     | 4 FRB 16/540<br>2 FRB 9/540                    |
|                |                |                 | 600            |                    |                |                                | 23172 CAC/W33<br>C 3172  |  |
| 380            |                |                 | 560            |                    |                |                                | 23076 CC/W33<br>24076 CC/W33                                     |  |
|                |                |                 | 620            |                    |                |                                | 23176 CA/W33   |  |
| 400            |                |                 | 600            |                    |                |                                | 23080 CAC/W33<br>24080 CAC/W33<br>C 3080                         |  |
|                |                |                 | 650            |                    |                |                                | 23180 CA/W33<br>C 3180   |  |

For missing dimensions and availability please consult SKF

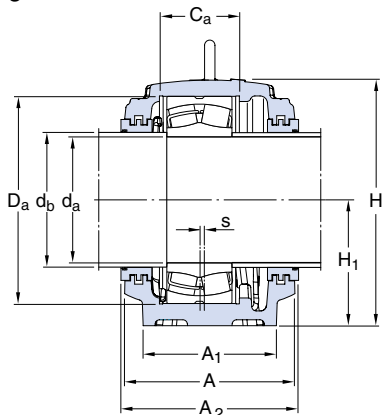

Labyrinth seals  
TS design

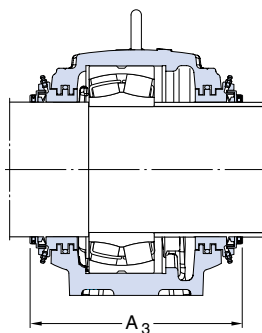

Taconite seals  
TNF design

| Shaft<br>d <sub>a</sub> | Housing<br>Dimensions |                |     |                |                |       |     | J <sub>1</sub> | L | N | N <sub>1</sub> | s | G | Mass<br>kg | Designations<br>Housing<br>complete with<br>two seals | Components<br>Housing only   | Seal | End cover |
|-------------------------|-----------------------|----------------|-----|----------------|----------------|-------|-----|----------------|---|---|----------------|---|---|------------|---|------------------------------|------|-----------|
|                         | A                     | A <sub>1</sub> | H   | H <sub>1</sub> | H <sub>2</sub> | J     |     |                |   |   |                |   |   |            |   |                              |      |           |
| mm                      | mm                    |                |     |                |                |       |     |                |   |   |                |   |   |            |   |                              |      |           |
| 420                     |                       |                | 360 |                | 870            |       | 220 |                |   |   |                |   |   |            | SNL 3084 GTS<br>SNL 3084 GTNF                         | SNL 3084 G<br>SNL 3084 G     |      |           |
|                         |                       |                |     | 410            |                | 1 000 |     | 260            |   |   |                |   |   |            | SNL 3184 GTS<br>SNL 3184 GTNF                         | SNL 3184 G<br>SNL 3184 G     |      |           |
| 440                     |                       |                | 380 |                | 950            |       | 240 |                |   |   |                |   |   |            | SNL 3088 GTS<br>SNL 3088 GTNF                         | SNL 3088 G<br>SNL 3088 G     |      |           |
|                         |                       |                |     | 420            |                | 1 030 |     | 260            |   |   |                |   |   |            | SNL 3188 GTS<br>SNL 3188 GTNF                         | SNL 3188 G<br>SNL 3188 G     |      |           |
| 460                     |                       |                | 420 |                | 1 030          |       | 260 |                |   |   |                |   |   |            | SNL 3092 GTS<br>SNL 3092 GTNF                         | SNL 3092 G<br>SNL 3092 G     |      |           |
|                         |                       |                |     | 440            |                | 1 070 |     | 260            |   |   |                |   |   |            | SNL 3192 GTS<br>SNL 3192 GTNF                         | SNL 3192 G<br>SNL 3192 G     |      |           |
| 480                     |                       |                | 410 |                | 1 000          |       | 260 |                |   |   |                |   |   |            | SNL 3096 GTS<br>SNL 3096 GTNF                         | SNL 3096 G<br>SNL 3096 G     |      |           |
|                         |                       |                |     | 460            |                | 1 110 |     | 260            |   |   |                |   |   |            | SNL 3196 GTS<br>SNL 3196 GTNF                         | SNL 3196 G<br>SNL 3196 G     |      |           |
| 500                     |                       |                | 420 |                | 1 030          |       | 260 |                |   |   |                |   |   |            | SNL 30/500 GTS<br>SNL 30/500 GTNF                     | SNL 30/500 G<br>SNL 30/500 G |      |           |

For missing dimensions and availability please consult SKF

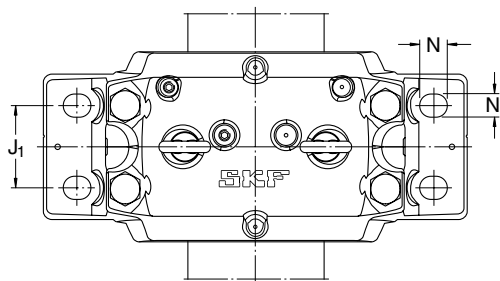
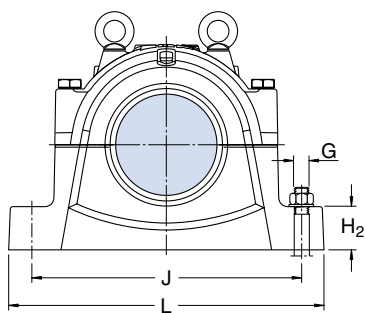

| Shaft          |                | Bearing seating |                | Width across seals |                | Eye bolts according to DIN 580 | Appropriate bearings and associated components<br>Spherical roller bearing    Locating rings<br>CARB bearing |
|----------------|----------------|-----------------|----------------|--------------------|----------------|--------------------------------|--|
| d <sub>a</sub> | d <sub>b</sub> | C <sub>a</sub>  | D <sub>a</sub> | A <sub>2</sub>     | A <sub>3</sub> |                                |  |
| mm             |                | mm              |                | mm                 |                | —                              | —  |
| 420            |                | 620             |                |                    |                |                                | 23084 CA/W33<br>24084 CA/W33   |
|                |                | 700             |                |                    |                |                                | 23184 C/W33  |
| 440            |                | 650             |                |                    |                |                                | 23088 CA/W33<br>24088 CA/W33   |
|                |                | 720             |                |                    |                |                                | 23188 CA/W33   |
| 460            |                | 680             |                |                    |                |                                | 23092 CA/W33<br>24092 CA/W33   |
|                |                | 760             |                |                    |                |                                | 23192 CA/W33   |
| 480            |                | 700             |                |                    |                |                                | 23096 CA/W33<br>24096 CA/W33   |
|                |                | 790             |                |                    |                |                                | 23196 CA/W33   |
| 500            |                | 720             |                |                    |                |                                | 230/500 CA/W33<br>240/500 CA/W33   |

For missing dimensions and availability please consult SKF

# Other products for trouble-free operation

## Robust, high-performance standard bearings

SKF produces the spherical roller bearings and CARB bearings normally incorporated in large SNL plummer block housings in many sizes and several designs. Both bearing types are self-aligning. The degree of misalignment which can be accommodated depends on the bearing series and also on the seals used in the SNL housings.

The spherical roller bearings can be used for both locating and non-locating bearing arrangements. At non-locating positions, the bearing outer ring is free to move axially in its seating in the housing bore. CARB bearings, on the other hand, accommodate axial displacements within the bearing and are always non-locating. It is usual to combine a CARB bearing at the non-locating side with a spherical roller bearing arranged as a locating bearing at the other side.

## Spherical roller bearings

The spherical roller bearings which can be used in large SNL plummer block housings are those of series 230, 231 and 240. The bearings are available with tapered bore for mounting on adapter or withdrawal sleeves, or with cylindrical bore. Sealed spherical roller bearings of ISO Dimension Series 22 can also be incorporated.

## CARB bearings

These bearings are a recent addition to the range of ball and roller bearings offered by SKF and are an SKF invention. CARB bearings of series C 30, C 31 and C 40 can be incorporated in large SNL plummer block housings.

Although available in a caged as well as a full complement version, it is normally recommended that caged bearings are used in SNL housings. CARB bearings are available with a tapered bore for mounting on an adapter sleeve or a withdrawal sleeve, as well as with a cylindrical bore.



## For easy mounting – adapter and withdrawal sleeves

Generally the bearings with a tapered bore incorporated in SNL plummer block housings are mounted on smooth or stepped shafts with the aid of an adapter sleeve or, on stepped shafts only, a withdrawal sleeve. These sleeves are produced by SKF in appropriate sizes for the range of bearings which can be used in SNL housings. The adapter sleeves are the more popular as they are more versatile and are easier to mount.

### Adapter sleeves

These are slotted sleeves with a tapered outside diameter. The sizes used with bearings for SNL housings have an external taper of 1:12 and are supplied complete with lock nut and locking washer. Their dimensions are in accordance with ISO 2982-1:1995.

When using adapter sleeves on smooth shafts it is possible to locate the bearing at any position on the shaft and no additional axial location is required.

### Withdrawal sleeves

These are also slotted sleeves with a tapered outside diameter. The sizes used with bearings for SNL housings have an external taper of 1:12. Their dimensions are in accordance with ISO 2982-1:1995.

Bearings on withdrawal sleeves must be mounted against a fixed abutment, e.g. a shaft shoulder. The withdrawal sleeve must be secured in position after it has been pressed into the bearing bore by a lock nut or end plate on the shaft. The nuts are not supplied with the sleeves.

### More information about

- spherical roller bearings (→ General Catalogue 4000 and brochure 5100)
- CARB bearings (→ brochure 5102)
- adapter and withdrawal sleeves (→ catalogue 3766)



## Other products

### Lock nuts

Lock nuts are used to axially locate bearings at shaft ends as well as to facilitate mounting and dismounting bearings on withdrawal sleeves. Several designs are available from SKF. They may also be referred to as shaft nuts or withdrawal nuts depending on the use to which they are put. Generally KM or KML nuts are those designs most used. They have four equally spaced slots around the circumference to take hook or impact spanners. The dimensions of the KM and KML nuts and the locking washers used with them are in accordance with ISO 2982-2:1995.



### Lubricating greases for bearings

Lubrication is a necessity for proper bearing performance. Grease is normally used for applications involving SNL plummer blocks. SKF has put considerable effort into establishing a range of high-quality greases for ball and roller bearing lubrication.

The SKF SYSTEM 24 automatic lubricator can also be used with SNL plummer block housings. An adapter can be fitted to the standard drilled and tapped hole in the housing cap. It should be remembered that surplus grease should be able to leave the housing.



### Pop Release units

These units are plummer blocks with ready-lubricated bearings for easy installation. They comprise

- a one-piece plummer block housing of grey cast iron,
- a spherical roller bearing of series 222 with special inner ring,
- a special adapter sleeve, and
- two seals of the "TriGard" type or two labyrinth seals.

The units are available in a locating and a non-locating version.



## Other bearing housings

To meet a wide variety of application demands, SKF produces a comprehensive range of bearing housings. The majority of these are of the split plummer block type but the SKF range also includes

- one-piece plummer block housings,
- flanged housings,
- take-up housings, and
- two-bearing housings.

Most of these housings are designed to take self-aligning bearings, principally spherical roller bearings, and the range extends to shaft diameters up to and including 1 800 mm. Housings are

available for oil lubrication as well as grease lubrication and also for bearings with cylindrical bore or for tapered bore, mounted on adapter or withdrawal sleeves. Smooth or stepped shafts can be used.

Various different types of seal are used. Most housings are made of grey cast iron but spheroidal graphite cast iron or cast steel housings are included in the range.

For further information, please contact SKF.

### *More information about*

- *lock nuts (→ brochure 4412)*
- *greases (→ leaflet MP319)*
- *Pop Release units (→ brochure 5103)*
- *housings (→ catalogue 4005)*



# The SKF Group - a worldwide corporation

SKF is an international industrial Group operating in some 130 countries and is world leader in bearings.

The company was founded in 1907 following the invention of the self-aligning ball bearing by Sven Wingquist and, after only a few years, SKF began to expand all over the world.

Today, SKF has some 40 000 employees and around 80 manufacturing facilities spread throughout the world. An international sales network includes a large number of sales companies and some 7 000 distributors and retailers. Worldwide availability of SKF products is supported by a comprehensive technical advisory service.

The key to success has been a consistent emphasis on maintaining the highest quality of its products and services. Continuous investment in research and

development has also played a vital role, resulting in many examples of epoch-making innovations.

The business of the Group consists of bearings, seals, special steel and a comprehensive range of other high-tech industrial components. The experience gained in these various fields provides SKF with the essential knowledge and expertise required in order to provide the customers with the most advanced engineering products and efficient service.



SKF



*The SKF Group is the first major bearing manufacturer to have been granted approval according to ISO 14001, the international standard for environmental management systems. The certificate is the most comprehensive of its kind and covers more than 60 SKF production units in 17 countries.*



*The SKF Engineering & Research Centre is situated just outside Utrecht in The Netherlands. In an area of 17 000 square metres (185 000 sq.ft) some 150 scientists, engineers and support staff are engaged in the further improvement of bearing performance. They are developing technologies aimed at achieving better materials, better designs, better lubricants and better seals – together leading to an even better understanding of the operation of a bearing in its application. This is also where the SKF Life Theory was evolved, enabling the design of bearings which are even more compact and offer even longer operational life.*



*SKF has developed the Channel concept in factories all over the world. This drastically reduces the lead time from raw material to end product as well as work in progress and finished goods in stock. The concept enables faster and smoother information flow, eliminates bottlenecks and bypasses unnecessary steps in production. The Channel team members have the knowledge and commitment needed to share the responsibility for fulfilling objectives in areas such as quality, delivery time, production flow etc.*



*SKF manufactures ball bearings, roller bearings and plain bearings. The smallest are just a few millimetres (a fraction of an inch) in diameter, the largest several metres. SKF also manufactures bearing and oil seals which prevent dirt from entering and lubricant from leaking out. SKF's subsidiaries CR and RFT S.p.A. are among the world's largest producers of seals.*

® SKF and CARB are registered trademarks of SKF.

© Copyright SKF 2001

The contents of this publication are the copyright of the publisher and may not be reproduced (even extracts) unless permission is granted. Every care has been taken to ensure the accuracy of the information contained in this publication but no liability can be accepted for any loss or damage whether direct, indirect or consequential arising out of the use of the information contained herein.

Publication **5101 E**

Printed in Denmark on environmentally friendly, chlorine-free paper (Multiart Silk) by Scanprint as.

[www.skf.com](http://www.skf.com)