



TSUBAKI EMERSON CAM CLUTCHES MZEU-K SERIES



WARNING

USE CARE TO PREVENT INJURY.

COMPLY WITH THE FOLLOWING TO AVOID SERIOUS PERSONAL INJURY.

1. Guards must be provided on all power transmission and conveyor applications in accordance with provisions of ANSI/ASME B 15.1 1992 and ANSI/ASME B 20.1 1993 or other applicable standards. When revisions of these standards are published, the updated edition shall apply.
2. Always lock out power switch before installing, removing, lubricating or servicing a system that uses Cam Clutch products.
3. If the Cam Clutch is used for repeated starting and stopping, make sure the strength of the supports for the Cam Clutch are sufficient.
4. The capacity of your Cam Clutch may be effected by the accuracy of its set up, the amount of pressure exerted on it, wear on other parts in your system, or wear life of the Cam Clutch itself. Check the Cam Clutch at regular intervals and take any necessary safety precautions.
5. When connecting or disconnecting Cam Clutch products, eye protection is required. Wear safety glasses, protective clothing, gloves and safety shoes.



TSUBAKI EMERSON CO.

Group Companies:

U.S. TSUBAKI, INC.
301 E. Marquardt Drive
Wheeling, IL 60090
U.S.A.
Phone : 847-459-9500
Facsimile : 847-459-9515

TSUBAKI of CANADA LIMITED
1630 Drew Road
Mississauga, Ontario, L5S 1J6
Canada
Phone : 905-676-0400
Facsimile : 905-676-0904

TSUBAKI AUSTRALIA PTY. LTD.
Unit E. 95-101 Silverwater Road
Silverwater, N.S.W. 2128
Australia
Phone : 02-9648-5269
Facsimile : 02-9648-3115

TSUBAKIMOTO (THAILAND) CO., LTD.
Room No. C, T.W.Y. Office Center,
10th Floor, Serm-Mit Tower,
159 Soi Asoke, Sukhumvit Road,
North-Klongtoey Wattana, Bangkok 10110
Thailand
Phone : 66-2-261-9991/2
Facsimile : 66-2-261-9993

TSUBAKIMOTO SINGAPORE PTE. LTD.
25 Gul Lane
Jurong
Singapore 629419
Phone : 68610422/3/4
Facsimile : 68617035

TAIWAN TSUBAKIMOTO CO.
No. 7 Feng Sun Keng
Kuei Shan-Hsiang, Taoyuan-Hsien
Taiwan R.O.C.
Phone : 03-3293827/8/9
Facsimile : 03-3293065

**TSUBAKI EMERSON CO.
TAIWAN BRANCH**
5th Fl., No. 2, Jen Ai Road, Sec.4, Taipei
Taiwan R.O.C.
Phone : 02-2325-9555
Facsimile : 02-2784-0022

1-1, Kotari-Kuresumi, Nagaokakyo, Phone : (075) 957-3131
Kyoto 617-0833, Japan Facsimile : (075) 957-3122
Internet:
<http://www.tsubaki-emerson.co.jp/english/>

TSUBAKIMOTO EUROPE B.V.
Belder 1, 4704 RK Roosendaal
The Netherlands
Phone : 0165-594800
Facsimile : 0165-549450

TSUBAKIMOTO U.K. LTD.
Osier Drive, Sherwood Park
Annesley, Nottingham, NG15 ODX
United Kingdom
Phone : 01623-688788
Facsimile : 01623-688789

TSUBAKIMOTO CHAIN CO.
Shanghai Representative Office
603 Unicom International Tower
547 Tianmu Xi Road, Shanghai,
China 200070
Phone : 021-6317-1662
Facsimile : 021-6317-0794

Distributed by:



MZEU-K SERIES CAM CLUTCHES

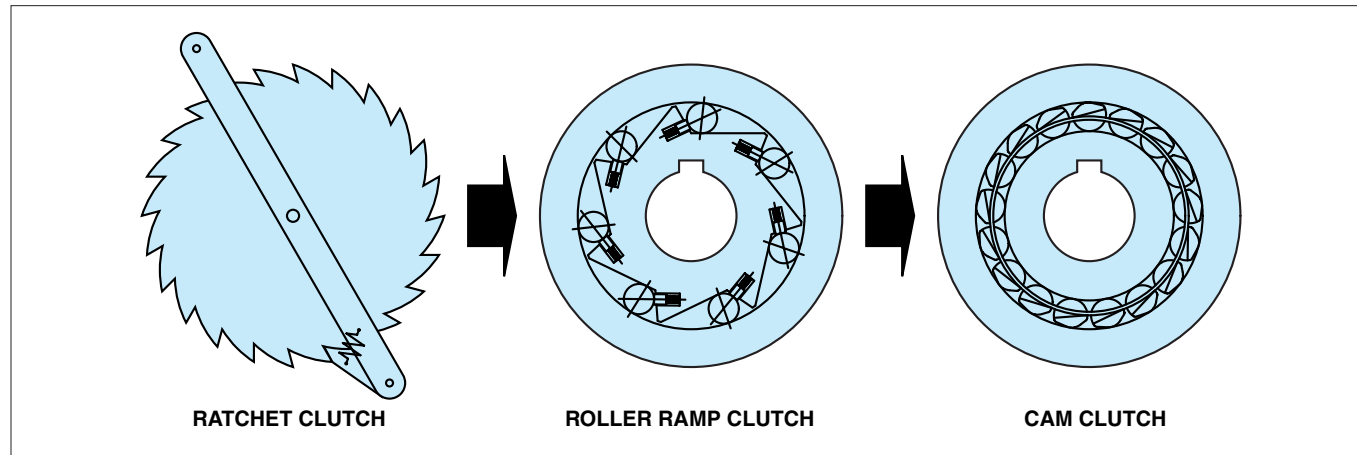

Tsubaki Cam Clutch is a sprag type one way clutch that is a leader in its class. The one way clutch was developed originally from Ratchet clutch that became the Roller ramp clutch that finally became the Tsubaki Cam Clutch, similar to the sprag type one way clutch. The Tsubaki Cam Clutch provides longer life to the clutch mechanism than other types of one way clutches. Tsubaki has a vast amount of experience producing this clutch and supplies it to many different industries throughout the world. The MZEU series Cam Clutch, the most recently developed one way clutch, is based on the historically proven European style one way clutch.



MZEU-K SERIES CAM CLUTCHES

Basic type

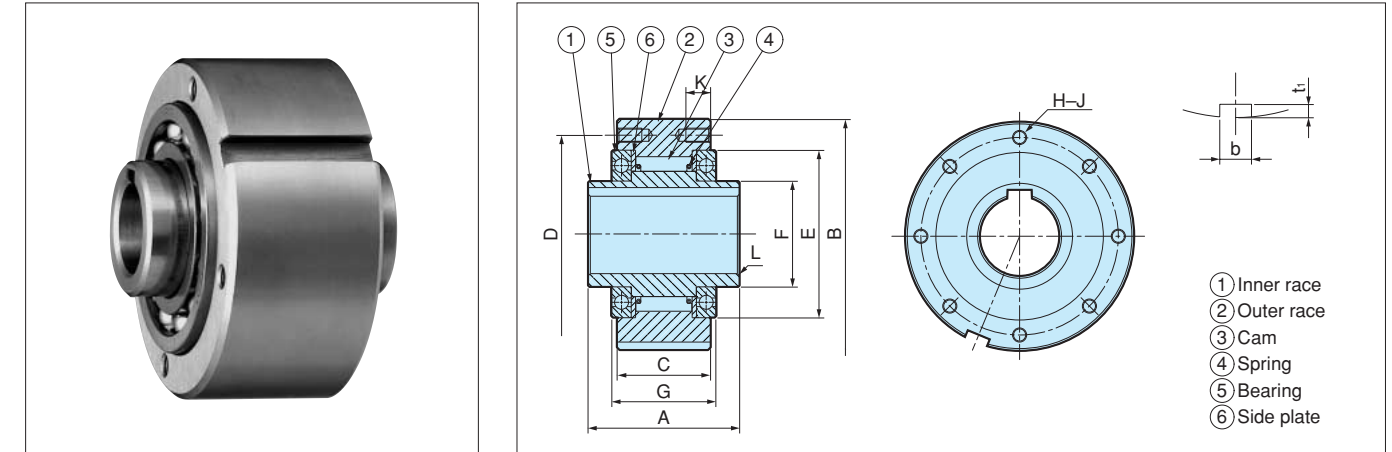

Dimensions and Capacity

Model	Torque Capacity	Max. Overrunning Speed		Drag Torque	Bore Size	Keyway	Dimensions in mm														Weight
	N·m	Inner Race	Outer Race				A	B	C	D	E	F	G	H-J	K	L	b	t ₁	kg		
		r/min	r/min	N·m	H7		h7									C	P10				
MZEU12K	60	2000	1000	0.20	12	4 × 1.8	42	62	20	51	42	20	27	3-φ5.5	—	0.8	4	2.5	0.5		
MZEU15K	100	1800	900	0.20	15	5 × 2.3	52	68	28	56	47	25	32	3-M5	8	0.8	5	3.0	0.8		
MZEU20K	245	1600	700	0.29	20	6 × 2.8	57	75	34	64	55	30	39	4-M5	8	0.8	6	3.5	1.2		
MZEU25K	425	1600	600	0.33	25	8 × 3.3	60	90	35	78	68	40	40	4-M6	10	0.8	8	4.0	1.8		
MZEU30K	735	1500	500	0.39	30	8 × 3.3	68	100	43	87	75	45	48	6-M6	10	1.0	8	4.0	2.6		
MZEU35K	1015	1400	300	0.49	35	10 × 3.3	74	110	45	96	80	50	51	6-M6	12	1.0	10	5.0	3.2		
MZEU40K	1350	1400	300	0.59	40	12 × 3.3	86	125	53	108	90	55	59	6-M8	14	1.3	12	5.0	4.8		
MZEU45K	1620	1400	300	0.69	45	14 × 3.8	86	130	53	112	95	60	59	8-M8	14	1.3	14	5.5	6.2		
MZEU50K	2070	1300	250	0.79	50	14 × 3.8	94	150	64	132	110	70	72	8-M8	14	1.3	14	5.5	8.2		
MZEU55K	2400	1300	250	0.88	55	16 × 4.3	104	160	66	138	115	75	72	8-M10	16	1.5	16	6.0	9.5		
MZEU60K	2950	1200	250	0.98	60	18 × 4.4	114	170	78	150	125	80	89	10-M10	16	1.5	18	7.0	12.3		
MZEU70K	4210	1100	250	1.27	70	20 × 4.9	134	190	95	165	140	90	108	10-M10	16	1.8	20	7.5	18.1		
MZEU80K	5170	800	200	1.38	80	22 × 5.4	144	210	100	185	160	105	108	10-M10	16	1.8	22	9.0	23.1		
MZEU 90	12000	450	150	4.70	90	25 × 5.4	158	230	115	206	180	120	125	10-M12	20	2.0	25	9.0	28.1		
MZEU100	17600	400	130	5.39	100	28 × 6.4	182	270	120	240	210	140	131	10-M16	24	2.0	28	10.0	46.3		
MZEU130	24500	320	110	6.76	130	32 × 7.4	212	310	152	278	240	160	168	12-M16	24	2.5	32	11.0	70.2		
MZEU150	33800	240	80	8.13	150	36 × 8.4	246	400	180	360	310	200	194	12-M20	32	2.5	36	12.0	146.3		

Installation and Usage

General Information for Installation and Usage

- MZEU-K series is a modular type Cam Clutch that the clutch is delivered with a Basic type Cam Clutch and option parts (E1, E2, E5, E7 flanges, E3 Torque arm and E4 cover) that are required as separate parts.
- Model No's. MZEU-K12 to MZEU-K80 is pre-greased and requires no lubrication. The ambient temperature range is -40°C to +40°C. Model No's. MZEU90 to MZEU150 require oil lubrication. Refer to lubrication and maintenance on page 9.
- We recommend a Shaft tolerance of h7, and DIN6885.1 keyway is standard.
- We recommend tolerance of E, H7 or H8 for sprocket, gear and other fitted parts.
- Clean the surface of both end of the outer race and the contact surfaces of the flange, torque arm and cover.
- For model No's. MZEU90 to MZEU150, apply seal adhesive to the surface of the outer race at both ends.
- Check the direction of rotation and attach the flange, torque arm or cover.
- When installing sprocket, gear, and other equipment to the clutch, fit them on the surface of the outer race or flange and screw the bolt in to them.
- By installing both option parts on the opposite side, the direction of rotation can be changed.
- Fix the grease nipple to the option parts.
- When mounting the clutch onto the shaft, apply pressure to the inner race but never to the outer race.
- For high speed indexing applications (More than 50 c/min) a strong spring type is recommended.

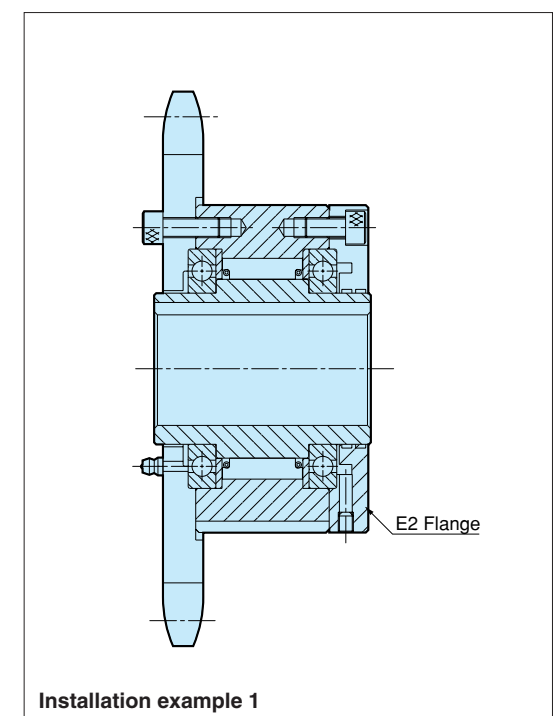

Installation example 1

MZEU-K SERIES CAM CLUTCHES

E1+E2

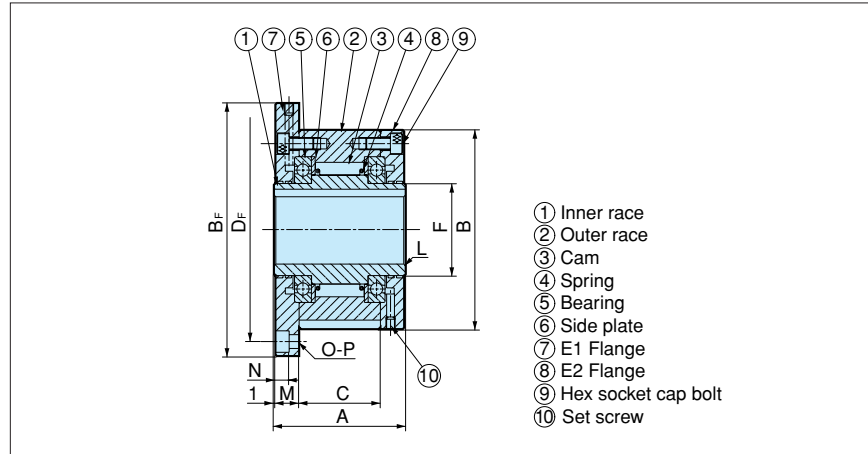

Dimensions and Capacity

Dimensions in mm

Model	Torque Capacity N·m	Max. Overrunning Speed		Drag Torque N·m	Bore Size H7	Keyway	A	B	B _F	C	D _F	F	L	M	N	O-P	Weight kg
		Inner Race r/min	Outer Race r/min														
MZEU12K E1+E2	60	2000	1000	0.20	12	4 × 1.8	42	62	85	20	72	20	0.8	10.0	5.7	3 – φ5.5	1.1
MZEU15K E1+E2	100	1800	900	0.20	15	5 × 2.3	52	68	92	28	78	25	0.8	11.0	5.7	3 – φ5.5	1.5
MZEU20K E1+E2	245	1600	700	0.29	20	6 × 2.8	57	75	98	34	85	30	0.8	10.5	5.7	4 – φ5.5	1.9
MZEU25K E1+E2	425	1600	600	0.33	25	8 × 3.3	60	90	118	35	104	40	0.8	11.5	6.8	4 – φ6.6	2.9
MZEU30K E1+E2	735	1500	500	0.39	30	8 × 3.3	68	100	128	43	114	45	1.0	11.5	6.8	6 – φ6.6	4.0
MZEU35K E1+E2	1015	1400	300	0.49	35	10 × 3.3	74	110	140	45	124	50	1.0	13.5	6.8	6 – φ6.6	5.2
MZEU40K E1+E2	1350	1400	300	0.59	40	12 × 3.3	86	125	160	53	142	55	1.3	15.5	9.0	6 – φ9.0	7.9
MZEU45K E1+E2	1620	1400	300	0.69	45	14 × 3.8	86	130	165	53	146	60	1.3	15.5	9.0	8 – φ9.0	9.3
MZEU50K E1+E2	2070	1300	250	0.79	50	14 × 3.8	94	150	185	64	166	70	1.3	14.0	9.0	8 – φ9.0	11.7
MZEU55K E1+E2	2400	1300	250	0.88	55	16 × 4.3	104	160	204	66	182	75	1.5	18.0	11.0	8 – φ11.0	15.3
MZEU60K E1+E2	2950	1200	250	0.98	60	18 × 4.4	114	170	214	78	192	80	1.5	17.0	11.0	10 – φ11.0	17.7
MZEU70K E1+E2	4210	1100	250	1.27	70	20 × 4.9	134	190	234	95	212	90	1.8	18.5	11.0	10 – φ11.0	25.5
MZEU80K E1+E2	5170	800	200	1.38	80	22 × 5.4	144	210	254	100	232	105	1.8	21.0	11.0	10 – φ11.0	33.2
MZEU 90 E1+E2	12000	450	150	4.70	90	25 × 5.4	158	230	278	115	254	120	2.0	20.5	13.0	10 – φ14.0	38.3
MZEU100 E1+E2	17600	400	130	5.39	100	28 × 6.4	182	270	335	120	305	140	2.0	30.0	17.5	10 – φ18.0	68.8
MZEU130 E1+E2	24500	320	110	6.76	130	32 × 7.4	212	310	380	152	345	160	2.5	29.0	17.5	12 – φ18.0	98.2
MZEU150 E1+E2	33800	240	80	8.13	150	36 × 8.4	246	400	485	180	445	200	2.5	32.0	21.5	12 – φ22.0	198.2

Installation and Usage

1. The clutch is delivered with a Basic type Cam Clutch, E1 flange, E1 flange and each flange kit as separate parts.
2. Check the direction of rotation and attach the each flange to the clutch.
3. When installing sprocket, gear and other equipment to the clutch, fit them on the surface of the outer race or flange and screw the bolt in to them.
4. By installing both option parts on the opposite side, the direction of rotation can be changed.
5. When mounting the clutch onto the shaft, apply pressure to the inner race but never to the outer race.
6. For high speed indexing applications (More than 50 c/min) a strong spring type is recommended.
7. Refer to page 9 for other usage.

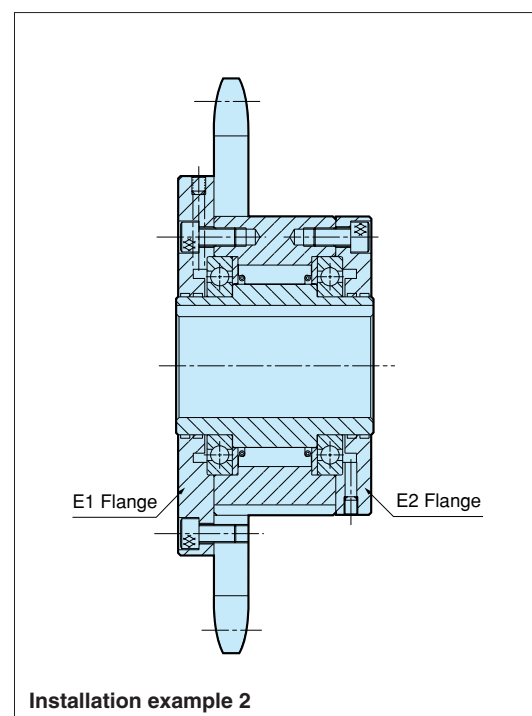

MZEU-K SERIES CAM CLUTCHES

E2+E3

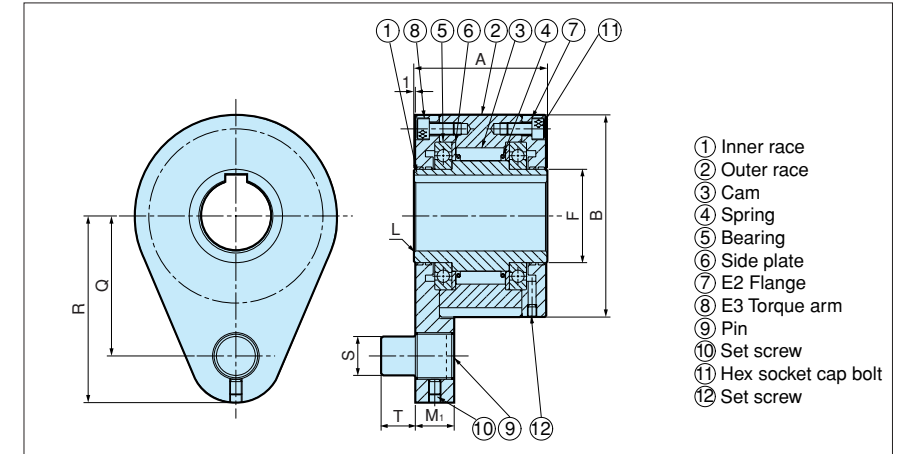

Dimensions and Capacity

Dimensions in mm

Model	Torque Capacity N·m	Max. Overrunning Speed		Drag Torque N·m	Bore Size H7	Keyway	A	B	F	L	M _i	Q	R	S	T	Weight kg
		Inner Race r/min	Outer Race r/min													
MZEU12K E2+E3	60	2000	1000	0.20	12	4 × 1.8	42	62	20	0.8	13.5	44	59	10	10	1.0
MZEU15K E2+E3	100	1800	900	0.20	15	5 × 2.3	52	68	25	0.8	13.5	47	62	10	10	1.4
MZEU20K E2+E3	245	1600	700	0.29	20	6 × 2.8	57	75	30	0.8	15.0	54	72	12	11	1.8
MZEU25K E2+E3	425	1600	600	0.33	25	8 × 3.3	60	90	40	0.8	19.0	62	84	16	14	2.7
MZEU30K E2+E3	735	1500	500	0.39	30	8 × 3.3	68	100	45	1.0	19.0	68	92	16	14	4.1
MZEU35K E2+E3	1015	1400	300	0.49	35	10 × 3.3	74	110	50	1.0	22.0	76	102	20	18	5.1
MZEU40K E2+E3	1350	1400	300	0.59	40	12 × 3.3	86	125	55	1.3	22.0	85	112	20	18	7.4
MZEU45K E2+E3	1620	1400	300	0.69	45	14 × 3.8	86	130	60	1.3	25.0	90	120	25	22	9.1
MZEU50K E2+E3	2070	1300	250	0.79	50	14 × 3.8	94	150	70	1.3	25.0	102	135	25	22	11.6
MZEU55K E2+E3	2400	1300	250	0.88	55	16 × 4.3	104	160	75	1.5	30.0	108	142	32	25	14.6
MZEU60K E2+E3	2950	1200	250	0.98	60	18 × 4.4	114	170	80	1.5	30.0	112	145	32	25	17.0
MZEU70K E2+E3	4210	1100	250	1.27	70	20 × 4.9	134	190	90	1.8	35.0	135	175	38	30	25.4
MZEU80K E2+E3	5170	800	200	1.38	80	22 × 5.4	144	210	105	1.8	35.0	145	185	38	30	32.6
MZEU 90 E2+E3	12000	450	150	4.70	90	25 × 5.4	158	230	120	2.0	45.0	155	205	50	40	38.9
MZEU100 E2+E3	17600	400	130	5.39	100	28 × 6.4	182	270	140	2.0	45.0	180	230	50	40	65.2
MZEU130 E2+E3	24500	320	110	6.76	130	32 × 7.4	212	310	160	2.5	60.0	205	268	68	55	97.3
MZEU150 E2+E3	33800	240	80	8.13	150	36 × 8.4	246	400	200	2.5	60.0	255	325	68	55	191.4

Installation and Usage

1. The clutch is delivered with a Basic type Cam Clutch, E2 flange, E3 torque arm and each kit as separate parts.
2. Check the direction of rotation and attach the flange and torque arm to the clutch.
3. When installing sprocket, gear and other equipment to the clutch, fit them on the surface of the outer race or flange and screw the bolt in to them.
4. By installing both option parts on the opposite side, the direction of rotation can be changed.
5. When mounting the clutch onto the shaft, apply pressure to the inner race but never to the outer race.
6. For high speed indexing applications (More than 50 c/min) a strong spring type is recommended.
7. Refer to page 9 for other usage.

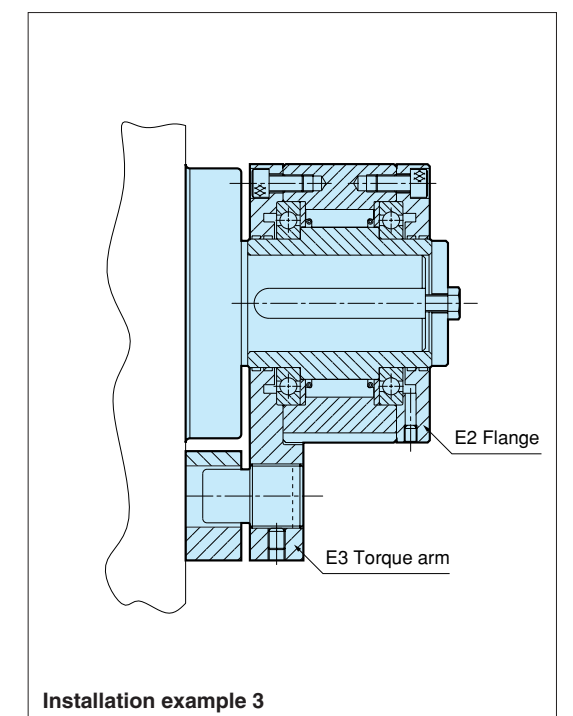

MZEU-K SERIES CAM CLUTCHES

E3+E4

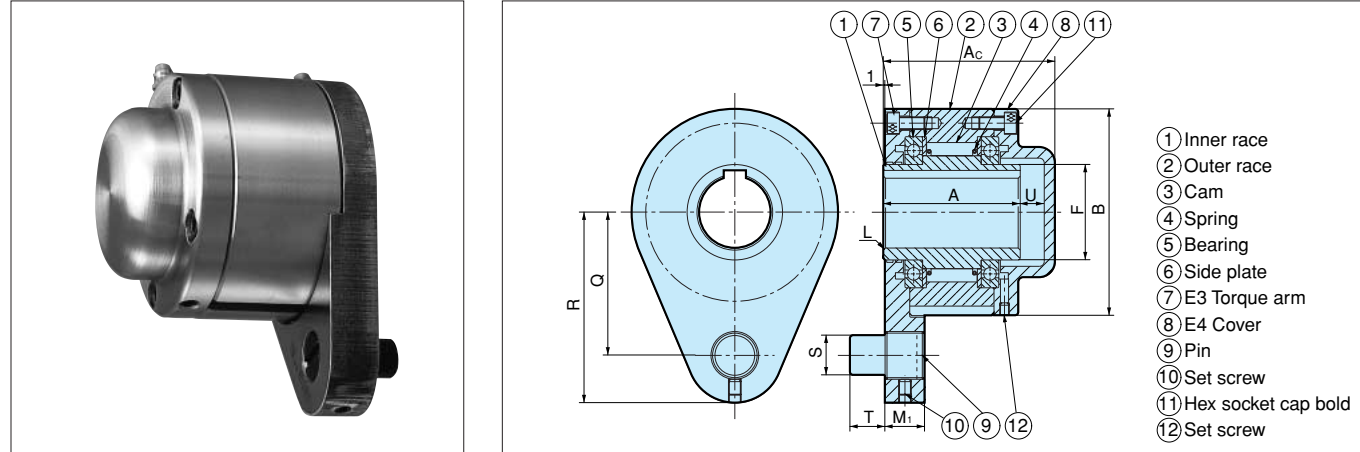

- ① Inner race
- ② Outer race
- ③ Cam
- ④ Spring
- ⑤ Bearing
- ⑥ Side plate
- ⑦ E3 Torque arm
- ⑧ E4 Cover
- ⑨ Pin
- ⑩ Set screw
- ⑪ Hex socket cap bolt
- ⑫ Set screw

Dimensions and Capacity

Dimensions in mm

Model	Torque Capacity N·m	Max. Overrunning Speed		Drag Torque N·m	Bore Size H7	Keyway	A	Ac	B	F	L	M ₁	Q	R	S	T	U	Weight kg
		Inner Race r/min	Outer Race r/min															
MZEU12K E3+E4	60	2000	1000	0.20	12	4 × 1.8	42	53	62	20	0.8	13.5	44	59	10	10	6	1.0
MZEU15K E3+E4	100	1800	900	0.20	15	5 × 2.3	52	68	68	25	0.8	13.5	47	62	10	10	10	1.5
MZEU20K E3+E4	245	1600	700	0.29	20	6 × 2.8	57	73	75	30	0.8	15.0	54	72	12	11	10	2.0
MZEU25K E3+E4	425	1600	600	0.33	25	8 × 3.3	60	76	90	40	0.8	19.0	62	84	16	14	10	2.9
MZEU30K E3+E4	735	1500	500	0.39	30	8 × 3.3	68	84	100	45	1.0	19.0	68	92	16	14	10	4.3
MZEU35K E3+E4	1015	1400	300	0.49	35	10 × 3.3	74	92	110	50	1.0	22.0	76	102	20	18	12	5.3
MZEU40K E3+E4	1350	1400	300	0.59	40	12 × 3.3	86	105	125	55	1.3	22.0	85	112	20	18	12	7.8
MZEU45K E3+E4	1620	1400	300	0.69	45	14 × 3.8	86	108	130	60	1.3	25.0	90	120	25	22	15	9.6
MZEU50K E3+E4	2070	1300	250	0.79	50	14 × 3.8	94	113	150	70	1.3	25.0	102	135	25	22	12	12.1
MZEU55K E3+E4	2400	1300	250	0.88	55	16 × 4.3	104	126	160	75	1.5	30.0	108	142	32	25	15	15.2
MZEU60K E3+E4	2950	1200	250	0.98	60	18 × 4.4	114	137	170	80	1.5	30.0	112	145	32	25	15	17.7
MZEU70K E3+E4	4210	1100	250	1.27	70	20 × 4.9	134	164	190	90	1.8	35.0	135	175	38	30	22.5	26.5
MZEU80K E3+E4	5170	800	200	1.38	80	22 × 5.4	144	168	210	105	1.8	35.0	145	185	38	30	16	33.6
MZEU 90 E3+E4	12000	500	150	3.76	90	25 × 5.4	158	192	230	120	2.0	45.0	155	205	50	40	27	39.0
MZEU100 E3+E4	17600	500	130	4.31	100	28 × 6.4	182	217	270	140	2.0	45.0	180	230	50	40	28	67.4
MZEU130 E3+E4	24500	400	110	5.39	130	32 × 7.4	212	250	310	160	2.5	60.0	205	268	68	55	30	100.2
MZEU150 E3+E4	33800	300	80	6.47	150	36 × 8.4	246	286	400	200	2.5	60.0	255	325	68	55	32	194.8

Installation and Usage

- The clutch is delivered with a Basic type Cam Clutch, E3 torque arm, E4 cover and each kit as separate parts.
- Check the direction of rotation and attach the each flanges to the clutch.
- When installing sprocket, gear and other equipment to the clutch, fit them on the surface of the outer race or flange and screw the bolt in to them.
- By installing both option parts on the opposite side, the direction of rotation can be changed.
- When mounting the clutch onto the shaft, apply pressure to the inner race but never to the outer race.
- For Model No's. MZEU-K12 to MZEU-K80, before mounting E4 cover to the clutch attach the end plate with bolts. Refer to installation example 4.
- For Model No's. MZEU90 to MZEU150, before mounting cover attach the packing between the end surface of inner race and the surface of the end plate, and using sealing washers and bolts. Refer to installation example 4.
- For high speed indexing applications (More than 50 c/min) a strong spring type is recommended.
- Refer to page 9 for other usage.

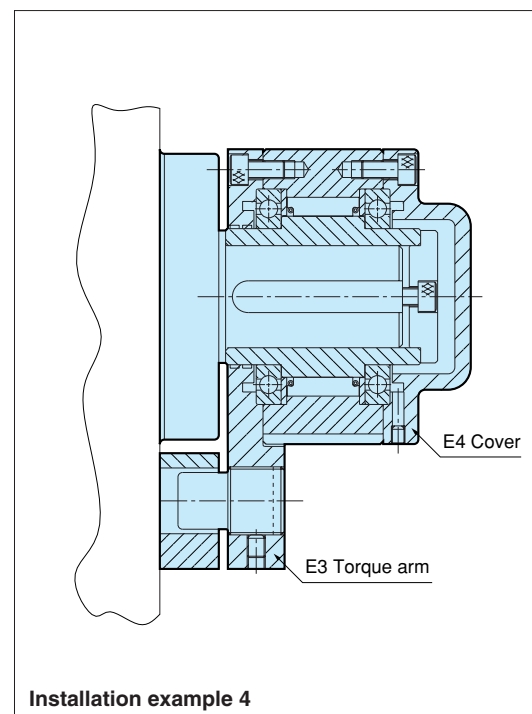

Installation example 4

MZEU-K SERIES CAM CLUTCHES

E5+E5

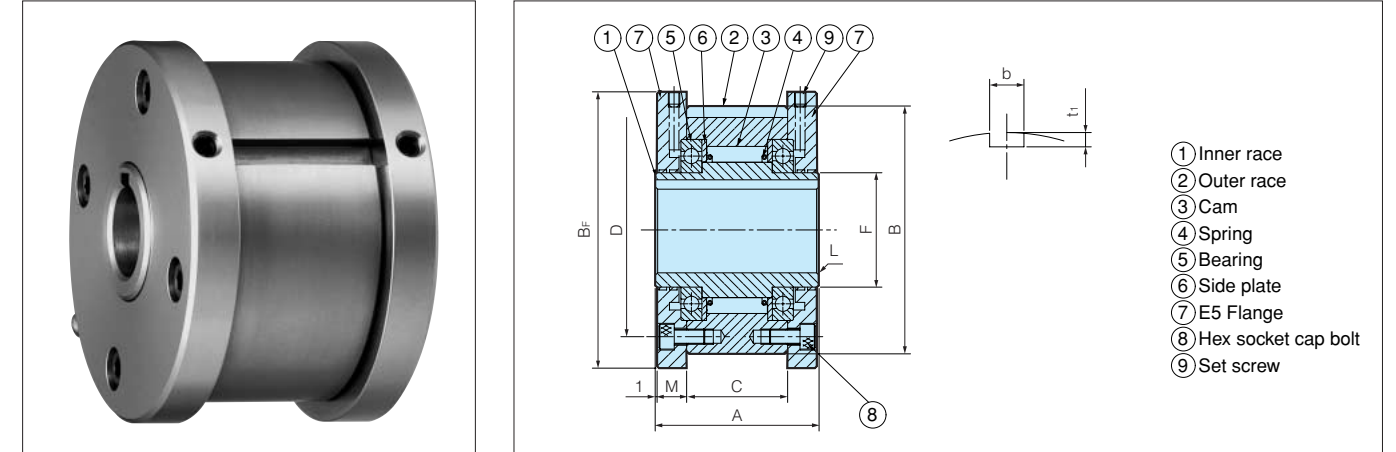

- ① Inner race
- ② Outer race
- ③ Cam
- ④ Spring
- ⑤ Bearing
- ⑥ Side plate
- ⑦ E5 Flange
- ⑧ Hex socket cap bolt
- ⑨ Set screw

Dimensions and Capacity

Dimensions in mm

Model	Torque Capacity N·m	Max. Overrunning Speed		Drag Torque N·m	Bore Size H7	Keyway	A	B	B _f	C	D	F	L	M	b	t ₁	Weight kg
		Inner Race r/min	Outer Race r/min														
MZEU12K E5+E5	60	2000	1000	0.20	12	4 × 1.8	42	62	70	20	51	20	0.8	10.0	4	2.5	0.5
MZEU15K E5+E5	100	1800	900	0.20	15	5 × 2.3	52	68	76	28	56	25	0.8	11.0	5	3.0	0.8
MZEU20K E5+E5	245	1600	700	0.29	20	6 × 2.8	57	75	84	34	64	30	0.8	10.5	6	3.5	1.2
MZEU25K E5+E5	425	1600	600	0.33	25	8 × 3.3	60	90	99	35	78	40	0.8	11.5	8	4.0	1.8
MZEU30K E5+E5	735	1500	500	0.39	30	8 × 3.3	68	100	109	43	87	45	1.0	11.5	8	4.0	2.6
MZEU35K E5+E5	1015	1400	300	0.49	35	10 × 3.3	74	110	119	45	96	50	1.0	13.5	10	5.0	3.2
MZEU40K E5+E5	1350	1400	300	0.59	40	12 × 3.3	86	125	135	53	108	55	1.3	15.5	12	5.0	4.8
MZEU45K E5+E5	1620	1400	300	0.69	45	14 × 3.8	86	130	140	53	112	60	1.3	15.5	14	5.5	6.2
MZEU50K E5+E5	2070	1300	250	0.79	50	14 × 3.8	94	150	160	64	132	70	1.3	14.0	14	5.5	8.2
MZEU55K E5+E5	2400	1300	250	0.88	55	16 × 4.3	104	160	170	66	138	75	1.5	18.0	16	6.0	9.5
MZEU60K E5+E5	2950	1200	250	0.98	60	18 × 4.4	114	170	182	78	150	80	1.5	17.0	18	7.0	12.3
MZEU70K E5+E5	4210	1100	250	1.27	70	20 × 4.9	134	190	202	95	165	90	1.8	18.5	20	7.5	18.1
MZEU80K E5+E5	5170	800	200	1.38	80	22 × 5.4	144	210	222	100	185	105	1.8	21.0	22	9.0	23.1
MZEU 90 E5+E5	12000	450	150	4.70	90	25 × 5.4	158	230	242	115	206	120	2.0	20.5	25	9.0	28.1
MZEU100 E5+E5	17600	400	130	5.39	100	28 × 6.4	182	270	282	120	240	140	2.0	30.0	28	10.0	46.3
MZEU130 E5+E5	24500	320	110	6.76	130	32 × 7.4	212	310	322	152	278	160	2.5	29.0	32	11.0	70.2
MZEU150 E5+E5	33800	240	80	8.13	150	36 × 8.4	246	400	412	180	360	200	2.5	32.0	36	12.0	146.3

Installation and Usage

- The clutch is delivered with a Basic type Cam Clutch, two E5 flanges, and flange kit as separate parts.
- Check the direction of rotation and attach an E5 flange to the clutch by the bolt.
- When installing sprocket, gear and other equipment to the clutch, install them on the outer race and fix the key between the equipment and the outer race.
- We recommend a tolerance of H7 for the bore of the sprocket, gear or other equipment.
- Attach the opposite side E5 flange to the clutch by the bolts.
- By installing the clutch to the shaft on the opposite side, the direction of rotation can be changed.
- When mounting the clutch onto the shaft, apply pressure to the inner race but never to the outer race.
- For high speed indexing applications (More than 50 c/min) a strong spring type is recommended.
- Refer to page 9 for other usage.

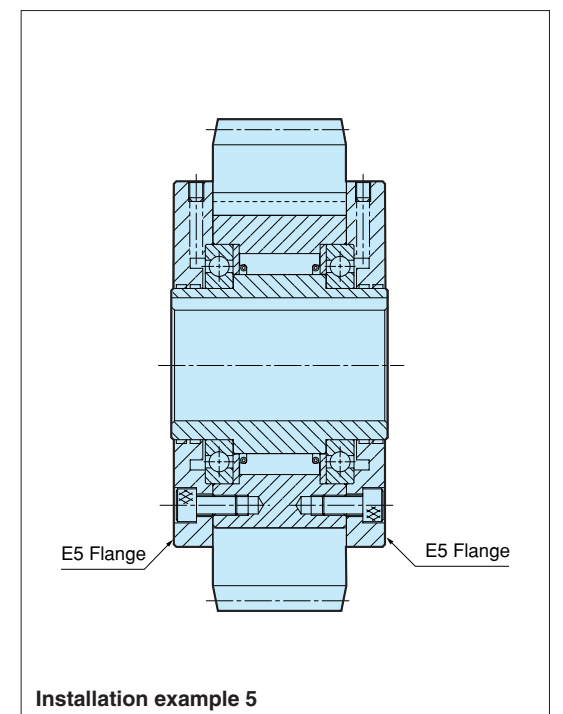

Installation example 5

MZEU-K SERIES CAM CLUTCHES

E2+E7

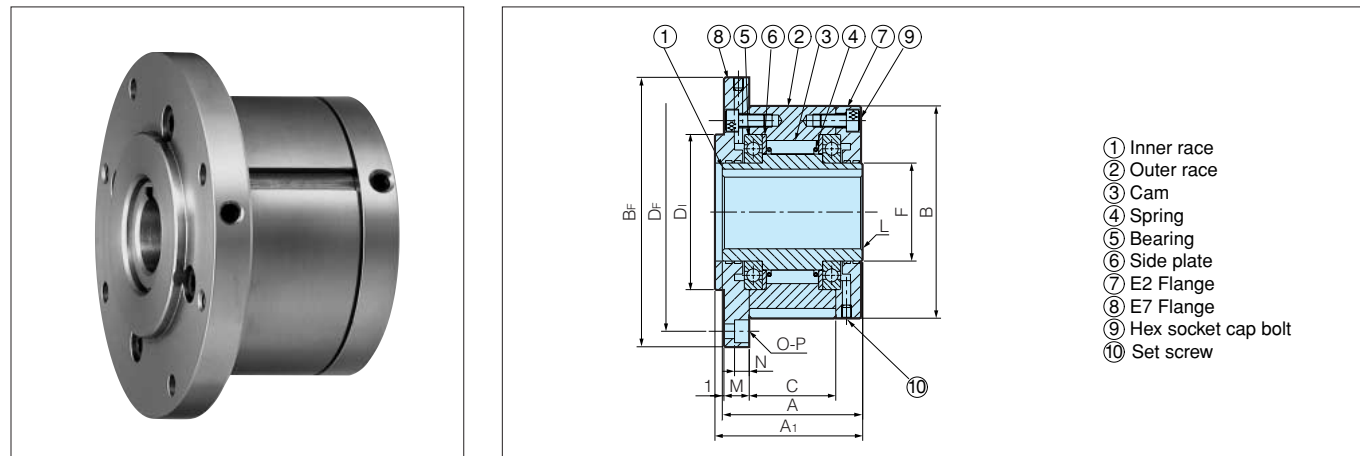

- ① Inner race
- ② Outer race
- ③ Cam
- ④ Spring
- ⑤ Bearing
- ⑥ Side plate
- ⑦ E2 Flange
- ⑧ E7 Flange
- ⑨ Hex socket cap bolt
- ⑩ Set screw

Dimensions and Capacity

Dimensions in mm

Model	Torque Capacity	Max. Overrunning Speed		Drag Torque	Bore Size	Keyway	Dimensions																Weight
	N·m	Inner Race	Outer Race				A	A ₁	B	B _F	C	D ₁	D _F	F	L	M	N	O-P	kg				
		r/min	r/min				h7	h7	h7	h7	h7	h7	h7	h7	h7	h7	h7	h7		h7			
MZEU12K E2+E7	60	2000	1000	0.20	12	4 × 1.8	42	44	62	85	20	42	72	20	0.8	10.0	5.7	3 - φ5.5	0.5				
MZEU15K E2+E7	100	1800	900	0.20	15	5 × 2.3	52	54	68	92	28	47	78	25	0.8	11.0	5.7	3 - φ5.5	0.8				
MZEU20K E2+E7	245	1600	700	0.29	20	6 × 2.8	57	59	75	98	34	55	85	30	0.8	10.5	5.7	4 - φ5.5	1.2				
MZEU25K E2+E7	425	1600	600	0.33	25	8 × 3.3	60	62	90	118	35	68	104	40	0.8	11.5	6.8	4 - φ6.6	1.8				
MZEU30K E2+E7	735	1500	500	0.39	30	8 × 3.3	68	70	100	128	43	75	114	45	1.0	11.5	6.8	6 - φ6.6	2.6				
MZEU35K E2+E7	1015	1400	300	0.49	35	10 × 3.3	74	76	110	140	45	80	124	50	1.0	13.0	6.8	6 - φ6.6	3.2				
MZEU40K E2+E7	1350	1400	300	0.59	40	12 × 3.3	86	88	125	160	53	90	142	55	1.3	15.0	9.0	6 - φ9.0	4.8				
MZEU45K E2+E7	1620	1400	300	0.69	45	14 × 3.8	86	88	130	165	53	95	146	60	1.3	15.0	9.0	8 - φ9.0	6.2				
MZEU50K E2+E7	2070	1300	250	0.79	50	14 × 3.8	94	96	150	185	64	110	166	70	1.3	13.0	9.0	8 - φ9.0	8.2				
MZEU55K E2+E7	2400	1300	250	0.88	55	16 × 4.3	104	106	160	204	66	115	182	75	1.5	17.0	11.0	8 - φ11.0	9.5				
MZEU60K E2+E7	2950	1200	250	0.98	60	18 × 4.4	114	116	170	214	78	125	192	80	1.5	16.0	11.0	10 - φ11.0	12.3				
MZEU70K E2+E7	4210	1100	250	1.27	70	20 × 4.9	134	136	190	234	95	140	212	90	1.8	17.5	11.0	10 - φ11.0	18.1				
MZEU80K E2+E7	5170	800	200	1.38	80	22 × 5.4	144	146	210	254	100	160	232	105	1.8	20.0	11.0	10 - φ11.0	23.1				
MZEU 90 E2+E7	12000	450	150	4.70	90	25 × 5.4	158	160	230	278	115	180	254	120	2.0	19.0	13.0	10 - φ14.0	28.1				
MZEU100 E2+E7	17600	400	130	5.39	100	28 × 6.4	182	184	270	335	120	210	305	140	2.0	28.0	17.5	10 - φ18.0	46.3				
MZEU130 E2+E7	24500	320	110	6.76	130	32 × 7.4	212	214	310	380	152	240	345	160	2.5	27.0	17.5	12 - φ18.0	70.2				
MZEU150 E2+E7	33800	240	80	8.13	150	36 × 8.4	246	248	400	485	180	310	445	200	2.5	30.0	21.5	12 - φ22.0	146.3				

Installation and Usage

- The clutch is delivered with a Basic type Cam Clutch, E2 flange, E7 flange and each flange kit as separate parts.
- Check the direction of rotation and attach the each flange to the clutch.
- When installing sprocket, gear and other equipment to the clutch, fit them on the surface of the outer race or flange and screw the bolt in to them.
- By installing both option parts on the opposite side, the direction of rotation can be changed.
- When mounting the clutch onto the shaft, apply pressure to the inner race but never to the outer race.
- For high speed indexing applications (more than 50 c/min) a strong spring type is recommended.
- Refer to page 9 for other Usage.

Note: Never apply the big overhang load to the outer race by using E7 flange to keep the centerline between the inner and outer race.

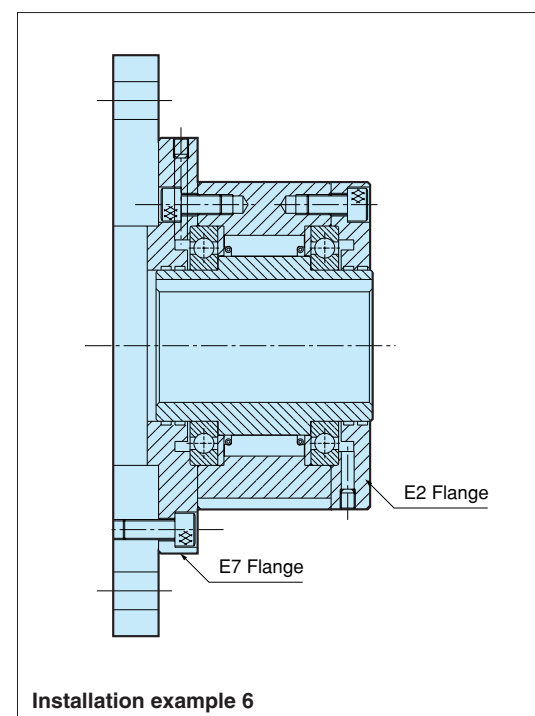

MZEU-K SERIES CAM CLUTCHES

COUPLING

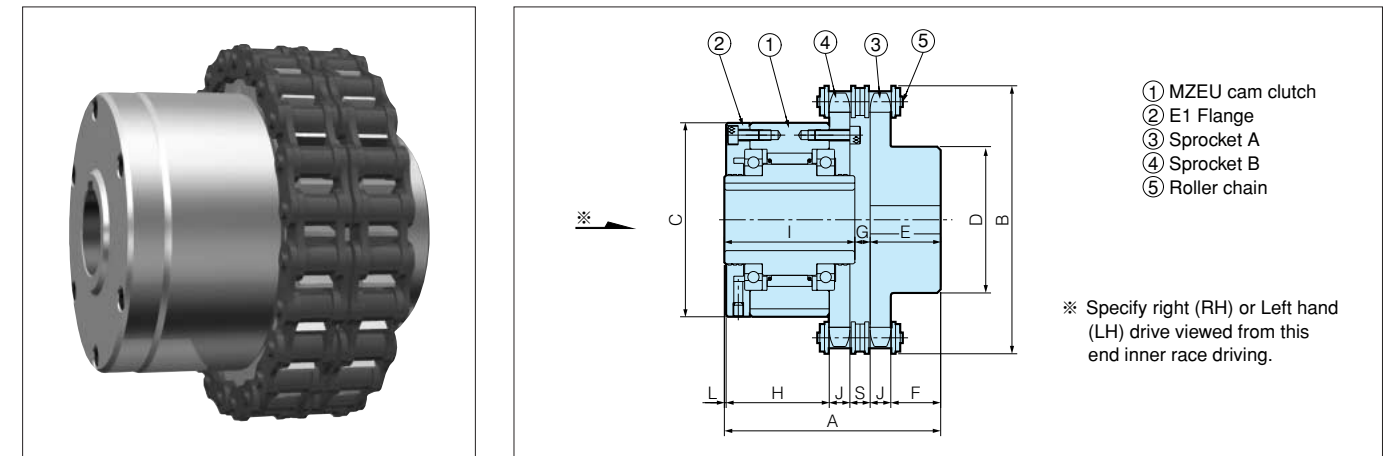

- ① MZEU cam clutch
- ② E1 Flange
- ③ Sprocket A
- ④ Sprocket B
- ⑤ Roller chain

※ Specify right (RH) or Left hand (LH) drive viewed from this end inner race driving.

Dimensions and Capacities

Dimensions in mm

Model	Torque Capacity	Max. Overrunning Speed		Drag Torque	Clutch Side		Coupling Side		Dimensions															
	N·m	Inner Race	Outer Race		Stock Bore Size	Bore Dia. Range	A	B	C	D	E	F	G	H	I	J	L	S						
		r/min	r/min		N·m	H7	Keyway	min.	max.	h7	h7	h7	h7	h7	h7	h7	h7	h7	h7					
MZEU12K-C	60	2000	1000	0.20	12	4 × 1.8	14	45	70.6	93	62	67	25	17.8	3.6	30.0	42	7.2	1	7.4				
MZEU15K-C	100	1800	900	0.20	15	5 × 2.3	14	50	79.6	101	68	75	25	17.8	2.6	39.0	52	7.2	1	7.4				
MZEU20K-C	245	1600	700	0.29	20	6 × 2.8	14	42	85.1	109	75	63	25	17.8	3.1	44.5	57	7.2	1	7.4				
MZEU25K-C	425	1600	600	0.33	25	8 × 3.3	18	47	93.9	127	90	73	28	19.3	5.9	46.5	60	8.7	1	9.7				
MZEU30K-C	735	1500	500	0.39	30	8 × 3.3	18	47	101.9	137	100	73	28	19.3	5.9	54.5	68	8.7	1	9.7				
MZEU35K-C	1015	1400	300	0.49	35	10 × 3.3	18	55	122.7	152	110	83	40	28.3	8.7	58.5	74	11.7	1	11.5				
MZEU40K-C	1350	1400	300	0.59	40	12 × 3.3	20	55	132.7	164	125	83	40	28.3	6.7	68.5	86	11.7	1	11.5				
MZEU45K-C	1620	1400	300	0.69	45	14 × 3.8	20	55	132.7	176	130	83	40	28.3	6.7	68.5	86	11.7	1	11.5				
MZEU50K-C	2070	1300	250	0.79	50	14 × 3.8	20	55	142.2	200	150	83	40	28.3	8.2	78.0	94	11.7	1	11.5				
MZEU55K-C	2400	1300	250	0.88	55	16 × 4.3	30	75	159.8	219	160	107	45	30.4	10.8	84.0	104	14.6	1	15.2				
MZEU60K-C	2950	1200	250	0.98	60	18 × 4.4	30	75	170.8	235	170	107	45	30.4	11.8	95.0	114	14.6	1	15.2				
MZEU70K-C	4210	1100	250	1.27	70	20 × 4.9	30	75	189.3	251	190	107	45	30.4	10.3	113.5	134	14.6	1	15.2				
MZEU80K-C	5170	800	200	1.38	80	22 × 5.4	30	75	196.8	267	210	107	45	30.4	7.8	121.0	144	14.6	1	15.2				

Installation and Usage

- MZEUK-C series Cam Clutch couplings make use of MZEUK series and CR type couplings without cover.
- Mount the Cam Clutch loosely on the high speed shaft at first.
- Accurately align both sprockets by checking with a straight edge on the teeth of both sprockets.
- Check whether the clearance(S) between both sprockets are correct, then wrap the chain around the sprockets.
- Specify right hand (RH) or left hand (LH) as inner race overrunning direction from the view of Cam Clutch side (※). See the above drawing.
- The same lubrication as for Tsubaki roller chain is necessary for the coupling chain.
- Ensure that the chain is properly closed with a connecting link and that the closed of the spring clip is installed in the same direction as the rotation of the outer race.

■LUBRICATION AND MAINTENANCE

Model No's. MZEU12 to MZEU80 are pre-greased and require no lubrication. The operational temperature range is -40°C to +40°C.

Model No's. MZEU90 to MZEU150 require oil lubrication.

Recommended Grease for Model No's. MZEU12 to MZEU80

Oil Company	Ambient Temperature	
	-5°C ~ +40°C	-40°C ~ +40°C
Esso	Beacon 2	Beacon 325
Mobil	Mobilux Grease No.2	Mobil temp SHC100
Shell	Alvania Grease No.2	Alvania Grease RA
BP	Energrease LS2	Energrease LT2
TOTAL	Multis 2	Aerogrease 22

Note: Do not use oil that contains EP additives.
E1~E4 options are supplied with bolts for installation, and grease nipple.

Recommended oil for from MZEU90 to MZEU150

Oil Company	Ambient Temperature	
	-10°C ~ +30°C	+30°C ~ +50°C
Esso	Telesso 32, Essolub D-3 10W, ATF Dexron	Essolub D-3 30
Mobil	ATF 220, Delvac 1310, DTE oil Light	Delvac 1330
Shell	Dexron II, Rimulla CT oil 10W,	Rimulla CT Oil 20W/20, 30
	Shell Clavus Oil 17, Rotella S Oil 10W	Rotella S Oil 20W/20, 30
BP	BP Energol THB32	—
Gulf	Harmony 32, Veritas SD10	Veritas SD30

Note: Do not use oil that contains EP additives.
Body (Basic type) is supplied with sealing adhesive.

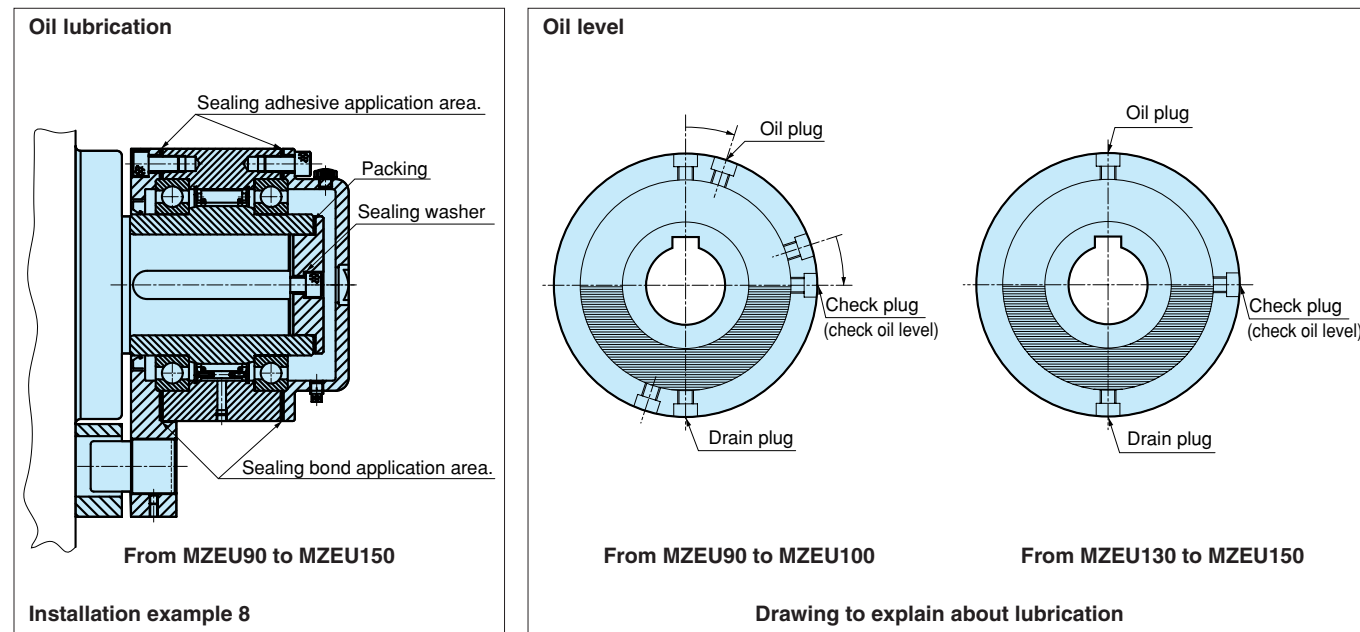

1. Apply a suitable amount of oil before use.
2. As a general rule, the amount of lubricant should be level with the center of the shaft for overrunning or backstopping.
3. The E2 flange has three plugs. The E4 cover has a large plug for adding oil and two small plugs for checking and draining.
4. Place the plugs, so that one is at the top and one is at the bottom. The center one should be level with the center of the shaft.
5. Pour oil into the clutch until it overflows from check plug. After a few minutes, pour in more oil and check that it overflows again.

MAINTENANCE

Model	Lubricant	Maintenance
MZEU12 ~ MZEU80	Grease	From the grease nipple on the flange, the torque arm and the cover add grease for both bearings every 3 months.
MZEU90 ~ MZEU150	Oil	Initially, replace oil after 10 hours of operation. Then replace it every 3 months. In a dirty environment, we recommend replacement every month.

TSUBAKI-EMERSON CAM CLUTCHES

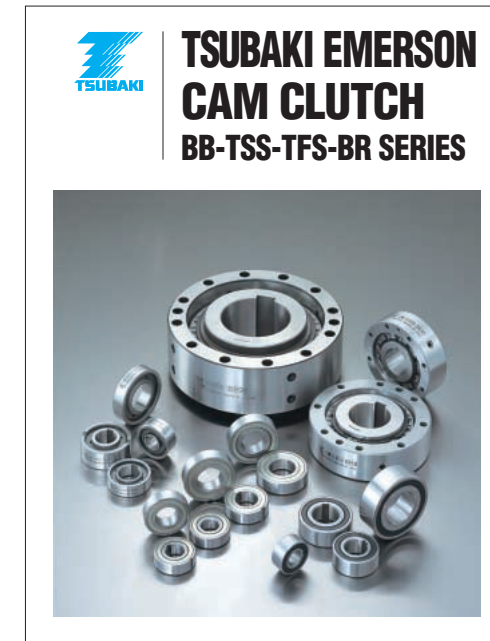

EUROPEAN STYLE CAM CLUTCH



EUROPEAN STYLE CAM CLUTCH



EUROPEAN STYLE CAM CLUTCH

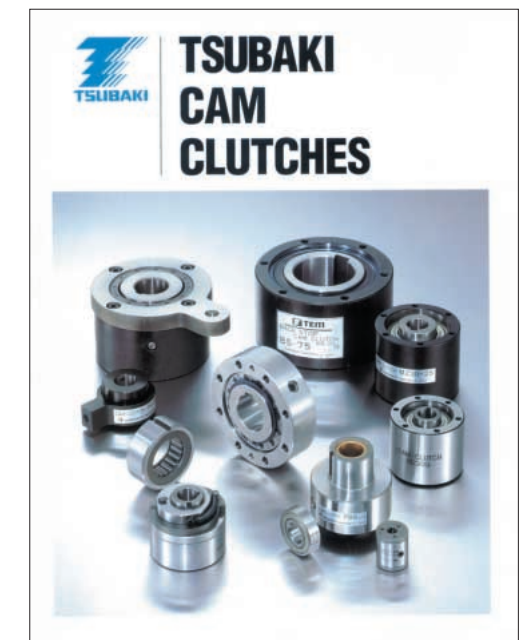

JAPANESE AND AMERICAN STYLE CAM CLUTCH