

Bearings for Screw Drives – just bolt them down

Gerald Nonnast and Martin Schreiber

INA reprint from "KEM"
No. 5, May 1999
Konradin-Verlag, Leinfelden-Echterdingen



Bearings for Screw Drives – just bolt them down

One more way to reduce costs for screw drive bearings

Gerald Nonnast and Martin Schreiber

In spite of technological innovations in screw drive bearings, the appeal of the conventional electromechanical drive concept has not been diminished. In addition to ongoing developments in bearing technology, higher cost-effectiveness of a bearing solution is becoming increasingly important. Total cost-savings potential is not the result of a less expensive bearing, but rather a cost-effective total solution. Most promising here are lower processing costs for the surrounding structure and simplified installation. At the same time there is a demand for more technical advantages over other conventional screw drive bearing arrangements.

1 Introduction

Besides linear direct drives, the electro-mechanical drive concept for machine shafts has consistently proven effective, especially since the EMO '97 trade show in Hanover.

One example that can be mentioned here is the locating/locating bearing type screw drive spindles. Besides the locating/locating bearings used on rotating spindles, design engineers are also focusing on driven screw drive nuts. Because they can generate higher feed power than the linear motor, these designs offer advantages in terms of greater moved masses and higher process forces. But the already significantly lower costs of electromechanical drives are being further optimized by the use of innovative screw drive bearings.

Apart from the technical performance potential, another way to reduce costs even more is to match components properly, such as servo drives in conjunction with screw drives.

Here clever bearing solutions in conjunction with the surrounding structure are of central significance. Such trends not only provide technological improvements, but are also responsive to the increasing demand for lower total-solution costs.

Bearings predrilled for flange mounting are ready-to-install units that provide state-of-the-art for screw drive bearing arrangements.

2 Contemporary bearings

Series ZKLF thrust angular-contact ball bearings are ready-to-install, self-retaining components (Fig. 1). They enable the direct mating of the bearing to the mounting structure without additional parts. This has positive effects on the rigidity and accuracy of the entire screw drive system. In contrast to single-bearing solutions, the number of slots is reduced to a minimum.

The seal is also integrated into the bearing. Additional parts in the surrounding structure are not necessary. For most applications, these bearings are delivered lubricated for life. For heavy loads concurrent with high speed, ZKLF series bearings are also available in a paired design.

Series DKLFA bearings were developed especially for locating/locating bearing type drive spindles (Fig. 2). These spindles are axially preloaded to compensate for heat expansion during operation and are called tensioned spindles. Under this design principle the bearings are permanently more heavily loaded in one direction because of the stretching force inside the spindle. This is accommodated by a third row that provides a one-sided support of higher axial loads. The bearing is likewise suitable for the vertical axis of a machine tool in which the bearing is constantly loaded by the carriage mass.

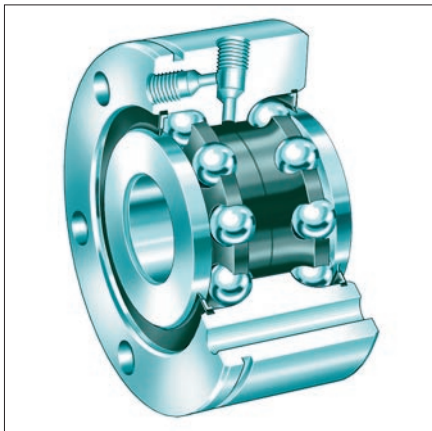

Fig.1 Series ZKLF bearing

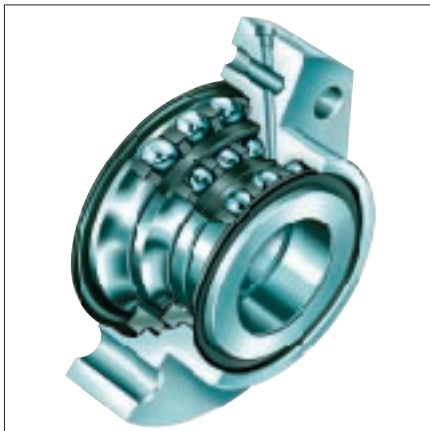

Fig. 2 Series DKLFA bearing

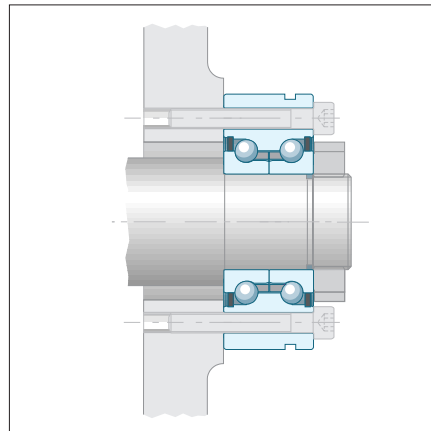

Fig. 3 Series ZKLF thrust angular-contact ball bearing bolted to a flat-milled surface

In addition, the DKLFA offers the same economical advantages as ZKLF bearings. Also, the DKLFA bearing's outer ring is flattened on both sides, which permits extremely low construction solutions. For the calculation of these complex, mechanically overdetermined configurations, INA's Engineering Service utilizes computer-assisted calculation facilities. This makes it possible to determine load carrying capacities as well as all relevant assembly parameters.

3 Bolt mounting

One option available to the designer working with bearings predrilled for flange mounting is direct bolting to a flat surface. No additional radial location is necessary. Both ZKLF and DKLFA bearings can be bolted to a flat-milled surface (Fig. 3). This design feature opens a whole new perspective for the economical and technologically advanced design for screw drive bearing arrangements.

4 The cost-effective solution

Besides selection on the basis of technical performance features, the cost-effectiveness of the systems solution is becoming increasingly important. Here comparing the costs of bearing variants demonstrates that the purchase price of the bearing should not be the primary consideration.

Total costs essentially include:

- the purchase price of the bearing
- costs for additional parts such as bearing caps, seals, sleeves, etc.
- processing costs for the surrounding structure
- mounting costs.

Figures 4 and 5 show the potential savings when the single Series ZKLF bearing is used. If the conventional approach with a modern design is

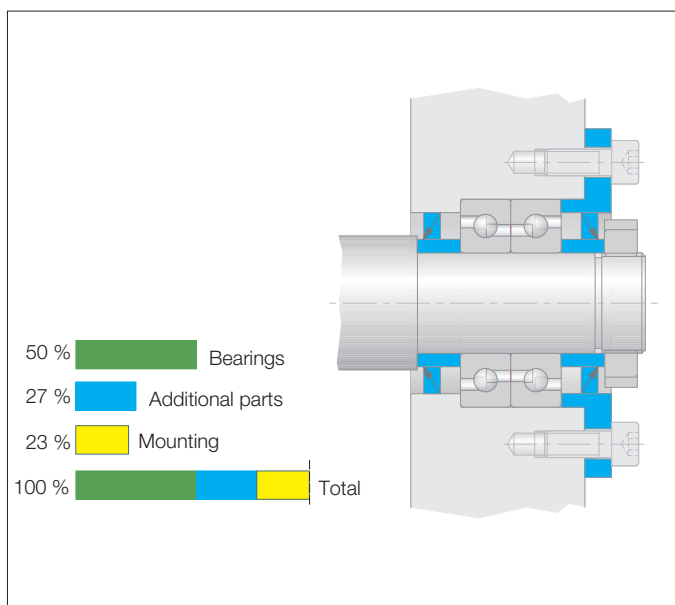

Fig. 4 Cost breakdown for bearing solution with single bearings

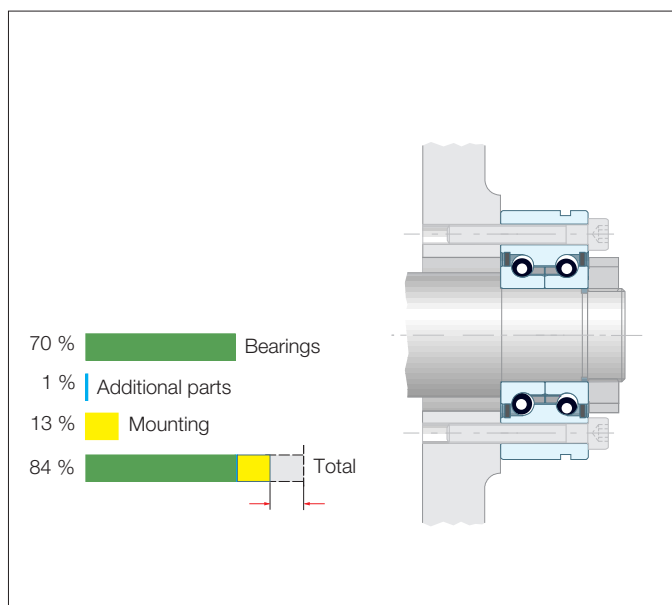

Fig. 5 Potential savings of a bolt-mounted ZKLF bearing solution

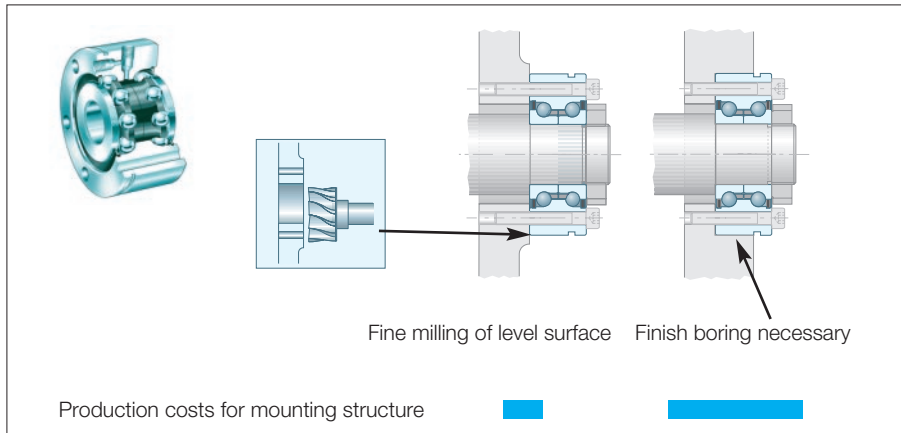

Fig. 6 Reducing production costs for the mounting structure by mounting the bearing to a flat surface

compared, the following becomes evident: the lower price of the conventional bearing does not make up for the higher costs for additional parts and assembly. For a state-of-the-art solution, not only is the higher price of the bearing compensated, but true savings are possible.

If production costs of the mounting structure are also included in the analysis, the result is a cost-optimized solution for a state-of-the-art screw drive bearing arrangement.

Figure 6 shows potential savings with a bolt-mounted ZKLF compared to a bearing mounted in a center bore. No grinding of the bearing seat is necessary – only fine-milling of the mating surface.

5 Mounting

The possibility of bolt-mounting the screw drive bearing to a flat surface greatly simplifies mounting. To achieve exact positioning of the bearing, the only thing that must be done is move the screw drive nut to its end positions.

One problem in the design stage is the radial positioning of the screw drive spindle bearing to a reference. The installation of a screw drive spindle with flat bolt-mounted bearing is very simple.

Here the position of the screw drive is the reference. The movable screw drive nut serves as a functional element for positioning the flange-mountable screw drive bearing. In the positioning process the

mounting screws of the bearing outer rings are first hand tightened, and then the screw drive nut is brought to the end positions. This places the spindle and bearing together in the optimum radial position (Fig. 7). The mounting screws are then tightened using the specified tightening torque in the feed path. This contributes to the reduction of additional radial loads on the bearing and screw drive nut and, ultimately, to a longer service life.

Another positive advantage in using the compact ZKLF bearing is that it minimizes the risk of error. The mounting process is reduced to only a few parts – the self-retaining bearing, the mounting screws and the precision locknut.

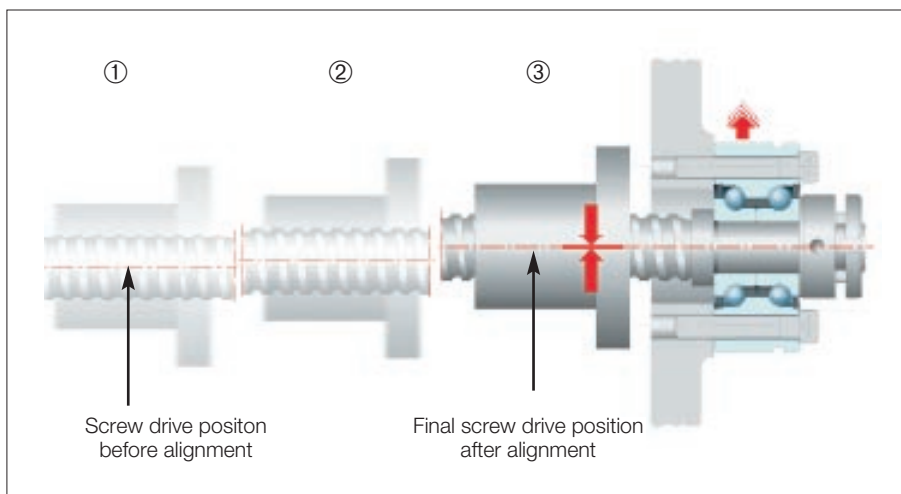

Fig. 7 Aligning the bearing by moving the screw drive nut

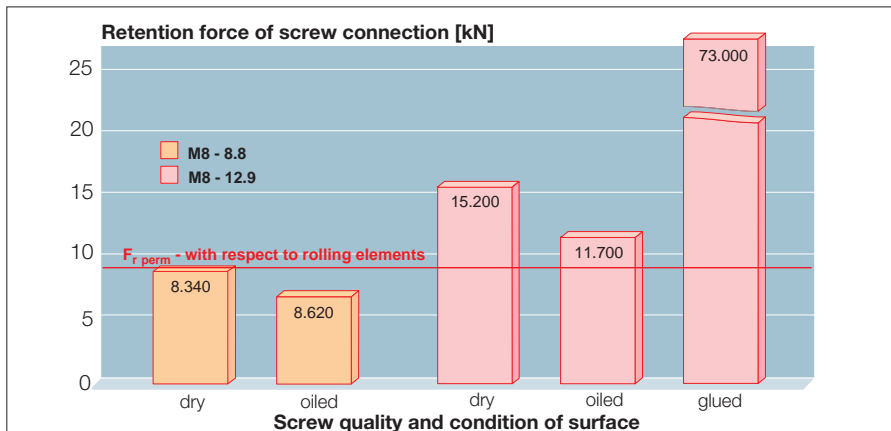

Fig. 8 Radial retention forces for ZKLF 30100.2 RS bearing screwed to a flat surface

6 No slippage

An important aspect of the solution discussed here is safeguarding the bearing against slippage. The maximum radial forces transmitted, such as those from the drive belt, were determined in tests.

Test results show that slippage does not occur until after the radial load-carrying capacity of the bearing is reached or exceeded. When strength class 8.8 screws are used, the maximum transferable radial load until slippage of the outer ring with dry parts corresponds approximately to the maximum permissible radial load (Fig. 8).

If a higher screw strength class (12.9) is selected and higher tightening torques are used, forces can be transferred which exceed the bearing's limit load in the radial direction. If the outer ring is glued (with Loctite 638 for example), the maximum transferable radial load can be increased significantly.

Results of tests conducted on screws of lower and higher strength classes indicate that the belt tensile loads that actually occur in applications are transmitted reliably with the class 10.9 screws recommended for locating ZKLF bearings.

7 Conclusion

Continuous development and new ideas with regard to the concept of electro-mechanical drives of linear axes have brought about new demands on drive components. For screw drive bearings this means that extensive improvements have been made on the product, and breakthroughs have also been made in the product's applications.

A modern screw drive bearing provides both the improved technical performance of machines as well as cost savings. Innovations for conventional drive concepts offer the designer a variety of advantages.

For instance, modern solutions based on many years of experience with electromechanical drives can be implemented. The big step toward a new design principle with effects on the total machine concept, as in the case of the linear motor, becomes unnecessary. And, compared to other designs, the electromechanical drive is a more appealing concept.

Literature:

- [1] INA Publication ZAE, "Bearings for screw drives", Herzogenaurach, November 1997
- [2] INA Publication "A wealth of experience with bearing arrangements for feed spindles", Herzogenaurach 1996
- [3] INA Test Report VA-67517 "Rutschlast für ZKLF", Herzogenaurach 1995

About the authors:

Gerald Nonnast is an Applications Engineer, and Martin Schreiber is Senior specialist in Applications Engineering in the Production Machines and Systems Industry Management at INA Wälzlager Schaeffler oHG.



INA Wälzlager Schaeffler oHG

D-91072 Herzogenaurach
Telephone (+49 91 32) 82-0
Fax (+49 91 32) 82-49 50
<http://www.ina.com>