

**WEAR- AND MAINTENANCE-FREE.**

# LINE SHAFTS

**SERIES ZA / ZAE | 10 – 4,000 Nm**



**R+W**<sup>®</sup>  
COUPLING TECHNOLOGY

THE ULTIMATE COUPLING FROM 10 – 4,000 Nm

[www.rwcouplings.com](http://www.rwcouplings.com)



# TORSIONAL STIFF LINE SHAFTS

## MODEL

## PROPERTIES

## APPLICATION EXAMPLES

### Application Examples:

Spanning of larger axial distances

- Palletizers
- Screw jack systems
- Multi-axis linear modules
- Printing machines

- Paper pulp machines
- Packaging machines
- Conveyor systems
- Textile machinery

- Crane gantry systems
- Automated assembly systems
- Woodworking machines
- Food processing machines



ZA

from 10 – 800 Nm

- Mounting + dismantling without moving the aligned machines
- Standard lengths up to 6 m (19.68 ft.)
- No intermediate support bearing required

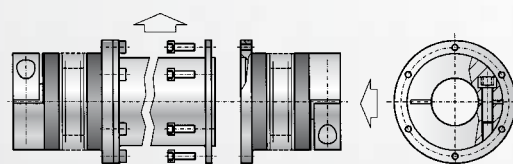

see page 3



ZA

from 1500 – 4000 Nm

- Mounting + dismantling without moving the aligned machines
- Standard lengths up to 3 m (9.84 ft.)
- No intermediate support bearing required

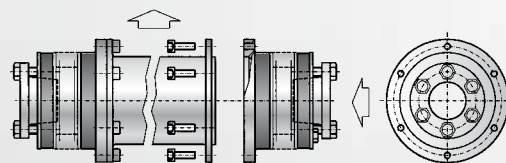

see page 4



ZAE

from 10 – 800 Nm

- Coupling radially removable
- easy mounting and dismantling by split hubs
- Standard lengths up to 6 m (19.68 ft.)
- No intermediate support bearing required

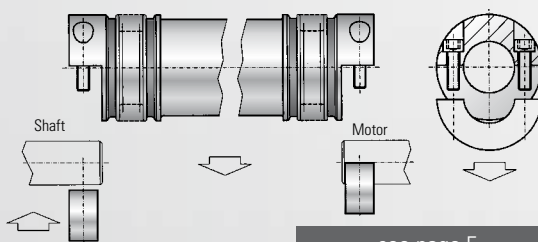

see page 5



EZ 2

line shaft with split clamping hub

- dampens vibrations
- easy mounting and dismantling by split hubs
- length up to 4 m
- no intermediate support bearing necessary
- radial mounting due to split hubs

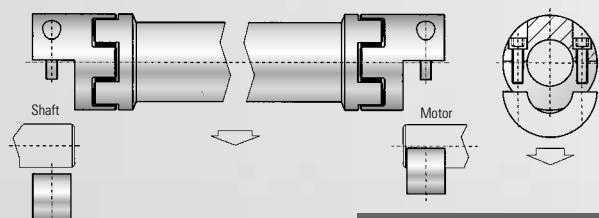

see separate catalog



EZV

von 10 – 800 Nm

- stepless adjustable in length
- dampens vibrations
- easy mounting and dismantling by split hubs
- length up to 4 m
- no intermediate support bearing necessary
- radial mounting due to split hubs

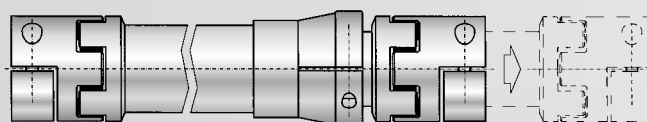

see separate catalog



# MODEL ZA 10-800 Nm

## TECHNICAL SPECIFICATIONS

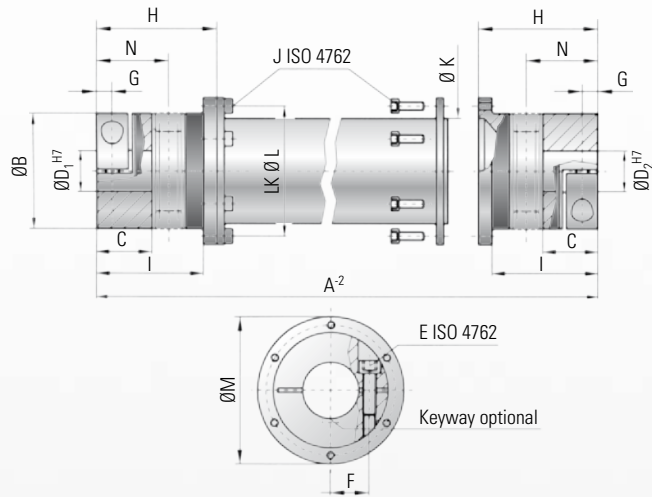

### Properties:

- Compensation of misalignments
- Backlash-free and torsionally stiff
- Able to span long distances
- Standard lengths up to 6 m ( 19.68 ft)
- No intermediate support bearing required
- Intermediate tube removable for easy mounting

### Material:

- Bellows made of flexible high grade stainless steel
- Aluminum intermediate tube section through size 200, size 300 and up steel
- **Optional composite CFK tube**
- Clamping hubs through size 60 Aluminum, size 150 and up steel

### Design:

- Balanced clamping hubs with one radial screw ISO 4762
- Intermediate tube section supported by gimbals within the clamping hub
- Mounting and dismounting accomplished through the removal of the intermediate tube section

-30 to +120° C (-3,6 to 270 F)

### Temperature range:

Depending on length A, please contact R+W

### Speed:

These couplings have an infinite life and are maintenance-free if the technical limits are not exceeded.

### Service life:

### Backlash:

Absolutely backlash-free due to frictional clamp connection

### Fit tolerance:

Shaft/hub connection 0.01 to 0.05 mm

### Ordering example

ZA / 10 / 1551 / 18 / 19 / XX

- Model
- Series/rated torque
- Overall length
- Ø D1 H7
- Ø D2 H7
- Non-Standard e.g. carbon tube

Model ZA 10 - 800 Nm		Series								
		10	30	60	150	200	300	500	800	
Rated torque (Nm)	T <sub>KN</sub>	10	30	60	150	200	300	500	800	
Overall length min. to max. (mm)	A <sup>2</sup>	110 to 6000	140 to 6000	170 to 6000	190 to 6000	210 to 6000	250 to 6000	260 to 6000	260 to 6000	
Outer diameter clamping hub (mm)	B	40	55	66	81	90	110	123	134	
Fit length (mm)	C	16	27	31	35.5	40.5	43	50	48	
Inner diameter from Ø to Ø H7 (mm)	D <sub>1/2</sub>	5 to 20	10 to 28	12 to 32	19 to 42	22 to 45	30 to 60	35 to 60	40 to 72	
With keyway max. Ø H7 (mm)	D <sub>1/2</sub>	17	23	29	36	45	60	60	66	
ISO 4762 clamping screw	E	M4	M6	M8	M10	M12	M12	M16	2x M16	
Tightening torque (Nm)	E	5	15	40	70	110	130	200	250	
	F	15	19	23	27	31	39	41	48	
	G	5	7.5	9.5	11	12.5	13	17	18	
Length bellows body (mm)	H	44.5	57.5	71	78	86	94	110	101	
	I	38.5	51	61	69	75.5	81	96	89	
ISO 4762 screw	J	4x M4	6x M4	6x M5	8x M6	8x M6	8x M8	8x M8	10x M8	
Tightening torque of the assembly screws (Nm)	J	3	4	7	10	12	30	30	40	
Outer diameter tube section (mm)	K	35	50	60	76	90	100	110	120	
Bolt hole circle Ø (mm)	L	45	62.5	71.5	88	100	120	132	138	
Outer diameter flange (mm)	M	52	70	80	98	110	135	148	153	
Shaft average value (mm)	N	25	34	41	47	52	56	66	64	

1Nm = 8.85 in lbs

max. permissible misalignment page 6

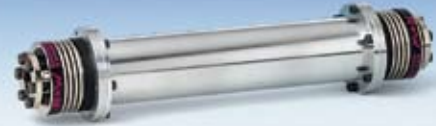

# MODEL ZA 1500-4000 Nm

## TECHNICAL SPECIFICATIONS

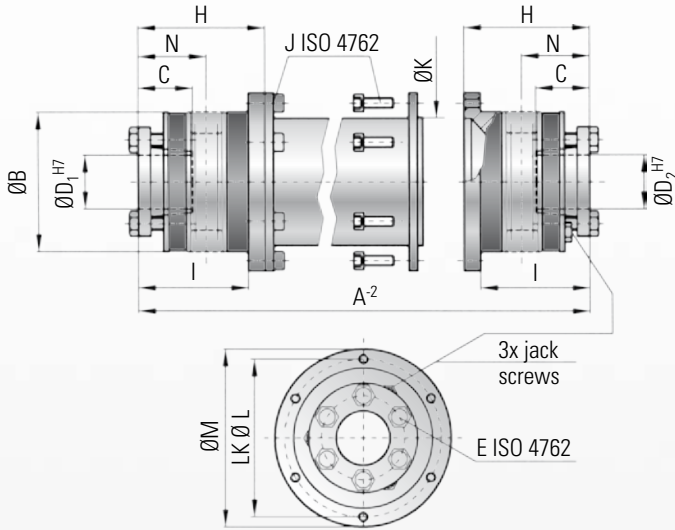

### Properties:

- Compensation of misalignments
- Backlash-free and torsionally stiff
- Able to span longer distances
- Standard lengths up to 3 m (9.84 ft)
- No intermediate support bearing required
- Intermediate tube removable for easy mounting

### Material:

- Bellows made of flexible high grade stainless steel
- Intermediate tube section: steel, **optional composite CFK tube**
- Clamping hubs: steel

### Design:

- With tapered conical sleeves and captive jack screws
- Intermediate tube section support by gimbals within the clamping hub.
- Lateral mounting and dismounting accomplished due to the removal of the intermediate tube section.

### Temperature range:

-30 to +120° C (-22 to 250° F)

### Speed:

Depending on length A, please contact R+W

### Service life:

These couplings have an infinite life and are maintenance-free if the technical limits are not exceeded

### Backlash:

Absolutely backlash-free due to frictional clamp connection

### Fit tolerance:

Shaft/hub connection 0.01 to 0.05 mm

### Ordering example

ZA / 1500 / 2551 / 65 / 70 / XX

Model  
Series/rated torque  
Overall length  
Ø D1 H7  
Ø D2 H7  
Non-Standard e.g. carbon tube

Model ZA 1500 - 4000 Nm		Series	
		1500	4000
rated torque (Nm)	T <sub>KN</sub>	1500	4000
Overall length min. to max. (mm)	A <sup>-2</sup>	240 to 3000	280 to 3000
Outer diameter (mm)	B	157	200
Fit length (mm)	C	61	80,5
Inner diameter from Ø to Ø H7 (mm)	D <sub>1/2</sub>	35 to 70	40 to 100
ISO 4017 clamping screws	6x E	M12	M16
Tightening torque (Nm)		70	120
Length bellows body (mm)	H	98	103,5
	I	82	84
ISO 4762 screw		10x M10	12x M12
Tightening torque of the assembly screws (Nm)	J	70	120
Outer diameter tube section (mm)	K	150	160
Bolt hole circle Ø (mm)	L	168	193
Outer diameter flange (mm)	M	184	213
Shaft average value (mm)	N	56	61

max. permissible misalignments page 6

### Vertical installation ZA/ZE

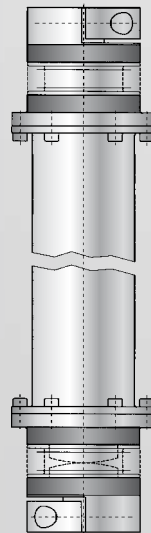

- While vertical mounting an additional supporting of the lower bellows body is necessary.
- A special bellows body for vertical mounting is available upon request.
- Please note „vertical mounting“ when ordering.



# MODEL ZAE 10-800 Nm

## TECHNICAL SPECIFICATIONS

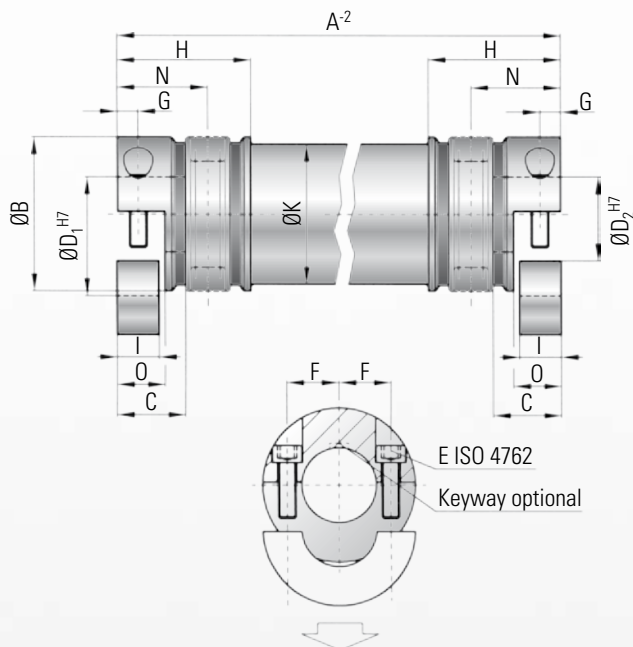

### Properties:

- Compensation of misalignments
- Backlash-free and torsionally stiff
- Able to span longer distances
- Standard lengths up to 6 m (19.68 ft)
- No intermediate support bearing required
- Split hubs for easy mounting and dismantling

### Material:

- Bellows made of flexible high grade stainless steel
- Aluminum intermediate tube section through size 150, size 300 and up steel
- optional composite CFK tube
- Clamping hubs through size 60 Aluminum, size 150 and up steel

### Design:

- Balanced split clamping hubs with two radial clamping screws ISO 4762
- Intermediate tube section supported by gim-bals within the clamping hub
- Lateral mounting and dismantling accom-plished due to split hubs

### Temperature range:

-30 to +120° C (-3,6 to 270 F)

### Speed:

Depending on length A, please contact R+W

### Service life:

These couplings have an infinite life and are main-tenance-free if the technical limits are not exceeded.

### Backlash:

Absolutely backlash-free through frictional clamp connection

### Fit tolerance:

Shaft/hub connection 0.01 to 0.05 mm

### Ordering example

ZAE / 10 / 1551 / 18 / 19 / XX

Model  
Series/rated torque  
Overall length  
Ø D1 H7  
Ø D2 H7  
Non-Standard e.g. carbon tube

Model ZAE 10 - 800 Nm		Series							
		10	30	60	150	300	500	800	
Rated torque (Nm)	T <sub>KN</sub>	10	30	60	150	300	500	800	
Overall length min. to max. (mm)	A <sup>2</sup>	100 to 6000	130 to 6000	160 to 6000	180 to 6000	240 to 6000	250 to 6000	250 to 6000	
Outer diameter clamping hub (mm)	B	40	55	66	81	110	123	133	
Fit length (mm)	C	16	27	31	34.5	42	50	47	
Inner diameter from Ø to Ø H7 (mm)	D <sub>1/2</sub>	5 to 20	10 to 28	12 to 32	19 to 42	30 to 60	35 to 60	40 to 72	
Max. inner diameter clamping hub (mm)	D <sub>max</sub>	24	30	32	42	60	60	75	
with keyway - max Ø H7 (mm)	D <sub>1/2</sub>	17	23	29	36	60	60	66	
ISO 4762 clamping screws	E	M4	M6	M8	M10	M12	M16	M16	
Tightening torque (Nm)		5	15	40	70	130	200	250	
	F	15	19	23	27	39	41	48	
	G	5	7.5	9.5	12	14	17	19	
Length bellows body (mm)	H	39.5	52	64	72	83	96	95	
Clamping length (mm)	I	10	15	19	22	28	33.5	37.5	
Outer diameter tube section (mm)	K	35	50	60	76	100	110	120	
	O	11.5	17	21	24	30	35	40	
Shaft average value (mm)	N	25	34	41	47	56	66	65	

1Nm = 8.85 in lbs



# NOTES

## SELECTION PROCESS FOR LINE SHAFTS MODELS ZA / ZAE

Series	Torsional stiffness of both bellows bodies $C_T^B$ (Nm/rad)	Torsional stiffness per 1m tube $C_T^{ZWR}$ (Nm <sup>2</sup> /rad)	Length of bellows body ZA H (mm)	Length of bellows body ZAE H (mm)	Distance between center lines N (mm)	max. axial misalignment $\Delta Ka$ (mm)
$T_{KN}$ (Nm)	$C_T^B$ (Nm/rad)	$C_T^{ZWR}$ (Nm <sup>2</sup> /rad)	H (mm)	H (mm)	N (mm)	$\Delta Ka$ (mm)
10	4,525	1,530	44.5	39.5	25	2
30	19,500	6,632	57.5	52	34	2
60	38,000	11,810	71	64	41	3
150	87,500	20,230	78	72	47	4
200	95,500	65,340	86	-	52	4
300	250,500	222,700	94	83	56	4
500	255,000	292,800	110	96	66	5
800	475,00	392,800	101	89	64	6
1500	1,400,000	728,800	92	-	56	4
4000	4,850,000	1,171,000	102	-	61	4

Table 1

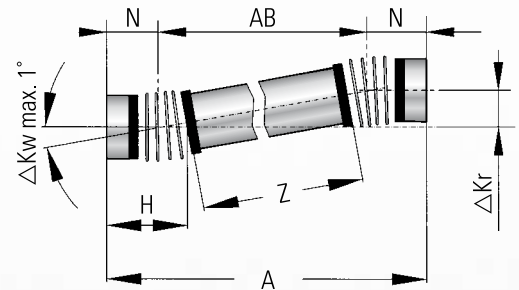

- A Overall length ZA m
- AB  $AB = (A - 2xN)$  m
- Z Tube length  $Z = (A - 2xH)$  m
- H Length of the bellows body mm
- N Distance between center lines mm
- $M_{max}$  Max. torque Nm
- $\varphi$  Angle of twist degree
- $C_T^B$  Torsional stiffness of both bellows bodies Nm/rad
- $C_T^{ZWR}$  Torsional stiffness of tube per meter Nm/rad
- $C_T^{ZA}$  Torsional stiffness of entire coupling Nm/rad

### Torsional stiffness:

$$(C_T^{ZA}) = \frac{C_T^B \times (C_T^{ZWR}/Z)}{C_T^B + (C_T^{ZWR}/Z)} \text{ [Nm/rad]}$$

### Angle of twist:

$$\varphi = \frac{180 \times M_{max}}{\pi \times C_T^{ZA}} \text{ [degree]}$$

**Example:** Line shaft ZA 150  $T_{KN} = 150$  Nm  
Wanted: Angle of twist at max. rated torque  $T_{KN}$

Length (A) of the shaft = 1.5 m  
Length (Z) of the tube =  $A - (2xH) = 1.344$ m

$$(C_T^{ZA}) = \frac{87.500 \text{ Nm/rad} \times (20.230 \text{ Nm/rad} / 1,344 \text{ m})}{87.500 \text{ Nm/rad} + (20.230 \text{ Nm/rad} / 1,344 \text{ m})} = 12.842,8 \text{ [Nm/rad]}$$

$$\varphi = \frac{180 \times 150 \text{ Nm}}{\pi \times 12.842,8 \text{ Nm/rad}} = 0,669^\circ$$

The result with a max. torque of 150 Nm is an angle of twist of 0.669°.

### Max. possible misalignment

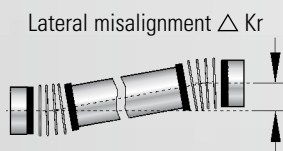

$$\Delta Kr = \tan \times AB$$

$$AB = A - 2 \times N$$

Axial misalignment  $\Delta Ka$

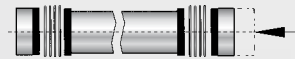

see Table 1

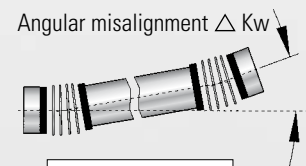

$$\Delta Kw = 2^\circ \text{ max.}$$

### R+W calculation programm for critical resonant speeds

With specially developed software R+W can calculate the critical resonant speeds for each application. The critical speed can be altered by changing the tube material and/or other parameters. Results of a calculation are shown on the right

- Critical resonant speed  $n_k = 1/\text{min.}$
- Torsional stiffness tube ZA/ZAE  $C_T^{ZWR} = \text{Nm/rad}$
- Total stiffness ZA/ZAE  $C_T^{ZA} = \text{Nm/rad}$
- Angle of twist  $\varphi = \text{degree-min-sec}$
- Weight of total axes  $m = \text{kg}$
- Mass moment of inertia  $J = \text{kgm}^2$
- Permissible lateral misalignment  $\Delta Kr = \text{mm}$



# ASSEMBLY INSTRUCTIONS

## Alignment

R+W ZA and ZAE line shaft couplings are available in lengths up to 6 meters (19.7 feet) without intermediate support bearings. To insure maximum life a proper alignment is necessary. We recommend laser alignment whenever possible. Other alignment techniques are also appropriate as long as the maximum permissible misalignment values listed on page 6 are not exceeded.

## Clamping hub

### ■ Model ZA (series 10 - 800 Nm)

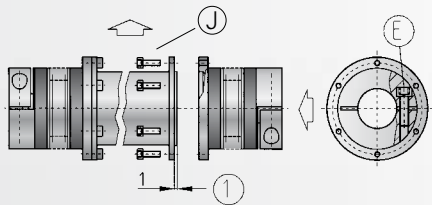

**Mounting:** Loosen Screw E and slide the metal bellows coupling segments onto each shaft end. Now insert the intermediate tube and assemble onto both metal bellows coupling segments using the assembly screws J. Tighten the assembly screws J to the correct torque indicated in the specification table. Center the entire line shaft coupling onto the shaft ends and tighten screw E by using a torque wrench to ensure the correct torque as indicated in the specification table.

**Dismounting:** Loosen Screw E on one end of the line shaft coupling. Remove assembly screws J on both ends of the line shaft coupling and remove the intermediate tube. Be sure to support the intermediate tube during removal. Depending on length this may require two people. Loosen Screw E on the second metal bellows coupling segment and slide both segments off.

### ■ Model ZAE (series 10 - 800 Nm)

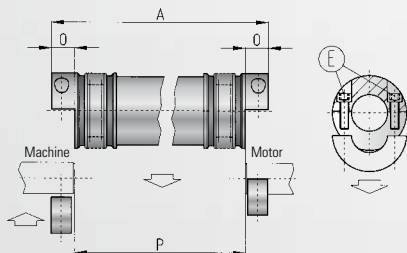

**Mounting:** First ensure that the distance between shaft ends exceeds the dimension P.

$$\text{Length P} = \text{length A} - 2 \times 0 \text{ [mm]}$$

Insert the line shaft coupling and assemble the split hubs with assembly screws E. Using a torque wrench to tighten screws E to the correct torque indicated in the specification table.

**Dismounting:** Remove the split hubs by removing the assembly screws E. Lift the line shaft coupling off the shaft ends.

## Conical sleeve

### ■ Model ZA (series 1500 - 4000 Nm)

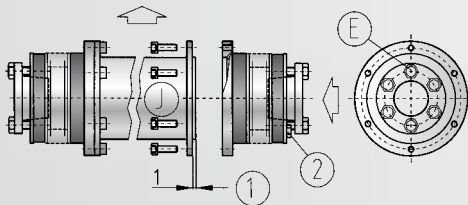

**Mounting:** Loosen Screws E (Do not remove!) and slide the metal bellows coupling segments onto each shaft end. Now insert the intermediate tube and assemble onto both metal bellows coupling segments by using the assembly screws J. Tighten the assembly screws J to the correct torque which is indicated in the specification table. Center the entire line shaft coupling onto the shaft ends and evenly tighten screws E while using a torque wrench. Ensure the correct torque as indicated in the specification table. Even tightening of screws E is critical to ensure that the shaft and metal bellows coupling segment are parallel.



**CAUTION! An over tightening of the screws E may destroy the tapered bushing connection. Do not exceed the tightening torque as specified in the specification table.**

**Dismounting:** Loosen the screws E on one side of the line shaft coupling. Using the three jack screws F to loosen the tapered segment so that it slides freely on the shaft. Remove the assembly screws J from both sides of the coupling and remove the intermediate tube. Be careful to support the tube during removal. Depending on the length of the tube this may require two people. Repeat the earlier procedure to remove the second metal bellows coupling segment.

**CAUTION! Be sure to lower the jack screws F before reassembly.**

## Maintenance

R+W line shafts are maintenance free. During routine inspections the line shafts should be visually controlled.



**Experience and  
Know-how  
for your special  
requirements.**

R+W Antriebselemente GmbH  
Alexander-Wiegand-Straße 8  
D-63911 Klingenberg/Germany

Tel. +49-(0)9372 – 9864-0  
Fax +49-(0)9372 – 9864-20

info@rw-kupplungen.de  
www.rwcouplings.com



TGA-ZM-05-91-00  
Registration No. 9605022

The information mentioned in this document is based on our present knowledge and experiences and does not exclude the manufacturer's own substantial testing of the equipment. So this is no obligatory assurance even with regard to protection rights of Third Parties. The sale of our products is subject to our General Conditions of Sale and Delivery.



**TORQUE LIMITERS  
Series SK**

From 0,1 – 2.800 Nm, Bore diameters 4 – 100 mm  
Available as a single position, multi-position, load holding, or full disengagement version  
Single piece or press-fit design



**BELLOW COUPLINGS  
Series BK**

From 15 – 10.000 Nm  
Bore diameters 10 – 180 mm  
Single piece or press-fit design



**BELLOW COUPLINGS  
ECONOMY CLASS  
Series BKL / BKC**

From 2 – 500 Nm  
Bore diameters 4 – 62 mm



**LINE SHAFTS  
Series ZA/ZE**

From 10 – 4.000 Nm  
Bore diameters 10 – 100 mm  
Available up to 6 mtr. length



**MINIATURE BELLOWS COUPLINGS  
Series MK**

From 0,05 – 10 Nm  
Bore diameters 1 – 28 mm  
Single piece or press-fit design



**SERVOMAX®  
ELASTOMER COUPLINGS  
Series EK**

From 2 – 2.000 Nm, Shaft diameters 3 – 80 mm  
backlash-free, press-fit design



**LINEAR COUPLINGS  
Series LK**

From 70 – 2.000 N  
Thread M5 – M16



**POLYAMID COUPLINGS  
MICROFLEX  
Series FK 1**

Rated torque 1 Ncm  
Bore diameters 1 – 1,5 mm