



PRECISION
INSTRUMENTS
& Machines

precision instruments
& Machines



LUOYANG BEARING PRECISION MACHINERY CO.,LTD

Website: <http://zysidd.com>

China bearing equipment&instrument web

Instrument Tel: (0379) 64629735 Fax: (0379) 64881595

Address: No.1 Jilin Road, Luoyang City, Henan Province, China

Machine Tel: (0379) 64367520 Fax: (0379) 64367597

Address: No.1 Wangxiang Road, Jianxi Science and Technology

Industrial Park, Luoyang City, Henan Province, China

Postcode: 471039

E-mail: 13623790339@139.com, xb@zysidd.com



INSTRUMENTS & Machines

LUOYANG BEARING PRECISION MACHINERY CO.,LTD



Company Introduction

Luoyang Bearing Precision Machinery Co., Ltd. is a holding subsidiary of the Luoyang Bearing Science & Technology Co., Ltd. , it is a high-tech enterprise in Henan Province. The company is located in Luoyang National High-tech Industrial Development Zone.

The company is inherited the Luoyang Bearing Science & Technology Co., Ltd. for 50 years in the equipment technology, precision instruments, technological achievements and talent advantages, more than 30 intermediate and senior technical staff, the company has been committed to the development and standard-setting in the field of the bearing processing equipment, bearing special measuring instrument, gas liquid lubrication areas , and other optical & electrical products, in these products, high-speed roundness instrument, bearing friction torque measuring instrument, laser roughness instrument, got national Invention Award and Science & Technology progress Award, more than 10 products such as precision ball sleeve bearing ring grinding, super-fine automatic production line, the surface topography measurement instrument, intelligent bearing vibration measuring instrument, etc. got Science & Technology progress Award in Henan Province and the machinery industry, moreover, the company got more than 20 invent patents, and more than 40 utility model patents.

The company is adopted modern enterprise system and management models, committed to provide you with advanced bearing processing technology and equipment, measuring instrument, precision air bearing, provided you with specialized equipment and measuring instruments. The company wishes you join hands and promote the development of China's bearing equipment and technology together.

Enterprise purpose:

Adopt international advanced research, production technology, scientific management; Provide high quality measuring instruments, processed equipment for bearing rings or other machinery parts; Dedicated service for users is our highest purpose.

Main product:

Instrument: Roundness measuring instrument, Cylindricity measuring instrument, Bearing friction torque measuring instrument, Bearing vibration measuring instrument, Bearing noise measuring instrument, Bearing dynamic radial & axial clearance measuring instrument, Bearing Bearing Convex value Measuring Instrument, Measuring Instrument for Contact Angle of Bearings, Duplex bearings pre-load & Axial Rigidity measuring instrument, Precision Bearing inner and Outer Ring Running Accuracy Measuring Instrument.

Equipment: Grinding and superfinishing autoline, Various bearing grinding and superfinishing process equipment, Roller superfinishing machine, Outer diameter lapping machine, Multi-purpose grinder, Pocket hole drilling machine, Turntable bearing assembly machine.

Precision parts: Various KD Series Air-floating spindle, MD Series Dense-ball spindle, Air-floating Turntable.



CONTENTS

Mechanical parts measuring instruments

◉ XM200 Surface Profile Measuring Instrument	01
◉ Y90 Series High-Speed Roundness & Waviness Measuring Instrument	03
◉ YZD400 Ultra-precision Cylindricity & Diameter Measuring Instrument	05
◉ S95 Single ball vibration measuring instrument	06
◉ CU Series laser roughness measuring instrument	07
◉ XZ-200 Shape Measuring Instrument	09
◉ R90 Series Bearing Ring Raceway Curvature Measuring Instrument	10

Finished Bearing Measuring Instruments

◉ X09J Series Bearing Radial Clearance Measuring Instrument	11
◉ X09Z Series Bearing Axial Clearance Measuring Instrument	12
◉ S09 Series Bearing Vibration Measuring instrument	13
◉ S09C Multi-functional bearing vibration measuring instrument	14
◉ M Series bearing Friction Torque Measuring Instrument	15
◉ T69 Series Bearing End-face Convexity Measuring Instrument	16
◉ GD6912 Bearing Axial Rigidity Measuring Instrument	17
◉ YJ6912 Matched bearings preload measuring instrument	18
◉ ZD9Q Series Multi-Parameters Bearing Bore & Outside Diameters Measuring Instrument ..	19
◉ B Series Precision Bearing inner and Outer Ring Running Accuracy Measuring Instrument ..	20
◉ J69 Series Contact Angle of Bearing Measuring Instrument	21
◉ BL series Rolling bearing dynamic performance measuring instrument	22

Precision Spindles

◉ Air-floating spindle	23
◉ Dense-ball spindle	24

Bearing precision grinding & SUPERFINISHING MACHINE

◉ CNC Internal Grinder For Ball Bearing Ring	25
◉ CNC Raceway Grinder For Ball Bearing Inner Ring	27
◉ CNC Raceway Grinder For Ball Bearing Outer Ring	28
◉ CNC Outer Raceway Grinder For Tapered Roller Bearing	29
◉ CNC Inner Raceway Grinder For Tapered Roller Bearing	30
◉ CNC Rib Grinder For Tapered Roller Bearing Inner Ring	31
◉ CNC Raceway Grinder For Thrust Ball Bearing	32
◉ Semi-Automatic Miniature Multipurpose Grinder	33
◉ Automatic Raceway Superfinishing Machine For Ball Bearing Inner Ring	34
◉ Automatic Raceway Superfinishing Machine For Ball Bearing Outer Ring	35
◉ CNC Raceway Superfinishing Machine For Angular Contact Ball Bearing	36
◉ Centerless Grinding Machine	37
◉ Super-Finishing Machine Series	38
◉ CNC Raceway Superfinishing Machine For Tapered Roller Bearing	39
◉ Cold Precision Rolling Machine	40
◉ CNC Raceway Grinder For Automobile Hub Bearing Inner Ring	41
◉ CNC Raceway Grinder For Automobile Hub Bearing Outer Ring	42
◉ CNC Grinder Special For Sewing Machine Rotating Shuttle Components	43
◉ CNC Automatic Production Line For Small Ball Bearing	44
◉ CNC Automatic Production Line For Tapered Roller Bearing	45
◉ Precision Machine Component Parts	45



Surface Profile Measuring Instrument

(Primary,Waviness,Roughness Profile Measuring)

XM-200



Absorbed the domestic and abroad advance experiences, XM200 surface profile measuring instrument has been improved based on the T2450 roller convexity measuring instrument (ministry of machine-building industry science and technology advancement prize, third grade). It is used to measure surface geometry and macro geometry for many kinds of machine parts.

Features

- X direction is used high-precision guide rail for line to move benchmarks, the move distance of guide rail is measured by grating technology.
- Z direction column is also used high-precision slide rail and encoders to measure, the ball screw system is driven by motor .
- Roughness and profile measurements. it can measure three-dimensional surface profile with workbench, the system can be used standalone, and it is flexible and convenient.
- Measuring software uses WINDOWS platform, using of the latest domestic standard definition , complete mathematical model.
- A variety of adjustable workbench, such as rotary workbench, V-type platforms etc, and user can freely choose according to need.
- More measuring parameters such as: linearity, curvature deviation, two grooves bearing various parameters, parallel deviation, height etc. it can also measure surface profile of the mechanical, roughness in strict accordance with domestic standards.
- High Measuring precision, inductance sensor resolution up to 0.01m , X direction grating resolution is 0.5 m, Z direction with encoder, it can measure large scale high-precision displacement.
- More control position, it can measure traditional small displacement in Z direction and displacement in X direction and the large displacement in Z direction. With control table in Y direction, it can measure three-dimensional surface profile of parts.
- Controlled by computer,it can mesure manually and automatically, it can automatically eliminate installation errors, automatically change range, directly display the shape and parameters, it can print output and has standard database for storing data.
- The X movement direction and Z movement direction of the sensor are controlled by the handles, the movement speed can realize stepless speed change

Technical Specitication

Part name	Content
X direction move Guide rail type Move distance Linear precision Measuring method	High-precision sliding rail 200mm 0.25 μ m Grating count,Resolution 0.5 μ m
Contour shape measuring Sensor Type Measuring range Display resolution Relative error	Inductance sensor ± 0.5 mm, ± 4 mm 0.001 μ m 0.02-0.1 %
Roughness measuring Measuring parameters Measuring range Display resolution Relative error	Ra,Rz,Ry,S,Sm,Tp Ra 0.01 ~ 10 μ m 0.001 μ m 2%+4nm
Z direction move (Column) Guide rail Type Move distance Driving Mode Measuring method	High-precision sliding rail 400mm Ball Screw Encoder
Accessory (Select) Three-dimensional adjust workbench rotay workbench	Level,obliquity,swinging angle adjustment Workpiece angle adjustment Ajust angle: $\pm 35^\circ$
y direction move (Purchase) Guide rail type Move distance Linear precision Measuring meshod	using for 3D surface profile Rolling rail 100mm 2 μ m/100mm Grating or encoder
Measuring software Software platform Function	Measuring parameters:profile/waciness/ roughness/ball or groove radlus/Groove-shaped deciation/straightness/Convexity/ball base surface radius/locking height/double groove center distance/chamfers size/Seal groove size Other functions:various assessment after one measurement,CAD annotation,automatically assessment length selection



High-Speed Roundness & Waviness Measuring Instrument

Y90 Series

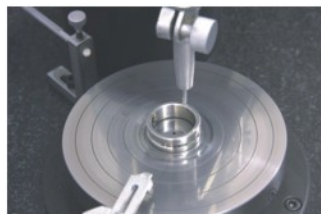

Roundness is an important indicator of production quality. The roundness value of bearing parts has a direct impact on the processing benchmark and rotary precision, noise, vibration, life expectancy, assembly quality of bearing.

Our corporation had successfully developed Y9025 high speed measuring instrument for bearing ring and ring part in the late seventies. The instrument well received by users because of its high measuring accuracy and easy adjustment, and it had got national invention prize, third grade. Enter the nineties, on this basis, we had developed the Y90 series high-speed Roundness Instrument the operation of this instrument is more convenient and the function is more powerful.

The type of Y9014, Y9020 and Y9025 instrument have similar structures but different measuring ranges. And the instrument is divided into different models according to the measuring accuracy, users can purchase them according to their needs.

Features

- High-precision air spindle, no wear and tear, the accuracy life is more than a decade.
- High speed rotation spindle, fast work piece adjustment, high measuring efficiency.
- High integrated circuit, general computer support, stability and reliability, easy maintenance.
- Efficient real-time processing software, it can display roundness profile graph simultaneously, real-time data processing, real-time display of measurement results.
- Completed hardware and software configurations, multiple fixtures, a variety of databases, LAN interface functions can be expanded for the user to choose.
- The interface is friendly, it can support DOS or WINDOWS system.
- The instrument can be placed in measuring room and the laboratory.

Technical Specification

Series product	Y9014G	Y9020G	Y9025G	Y9030G
Measuring range	d > φ5 D < φ140 H < 100	d > φ5 D < φ200 H < 100	d > φ10 D < φ250 H < 100	d > φ10 D < φ300 H < 100
Spindle speed	115r/min		60r/min	
Measuring efficiency	50 ~ 120 pieces/h		40 ~ 100 pieces/h	
Resolution	0.01 μm			
Filter	2 ~ 15, 2 ~ 50, 2 ~ 150, 2 ~ 500, 15 ~ 150, 15 ~ 250, 15 ~ 500, 1			
Magnification	100, 200, 400, 800, 1000, 2000, 4000, 8000, 10000, 20000, 40000, 80000			
Assessment method	Least square circle (LSC), minimum area (MZC), minimum inscribed circle (MIC), minimum zone circle (MCC)			
Other features	Slope analysis, Harmonic analysis, Graph display, Print, Data storage, Report, LAN			
Spindle work pressure	0.4 ~ 0.43MPa			
Air source pressure	0.45 ~ 0.8MPa			
Environmental requirements	Temperature: (10 ~ 30) °C Relative humidity: < 85 %			
Power requirements	About 400W, AC220V±10%, 50HZ			

Notes: we can design and processing large size and low-speed measuring instrument for roundness base on user requirement.



Ultra-precision Cylindricity & Diameter Measuring Instrument

(Cylindricity/Roundness/Straightness/Verticality/Flatness/Diameter)

YZD-400



YZD-400 Ultra-precision Cylindricity & Diameter Measuring Instrument can measure roundness, cylindricity, diameter of the mechanical components by radial-method, it is widely used in many industries such as aviation, aerospace, automobile, machine, electronic, etc., it is an indispensable instrument in machining process of the precision components.

YZD-400 Ultra-precision Cylindricity & Diameter Measuring Instrument is mainly composed of air-floating bench, precision column air slideway, inductance sensor, precision grating measuring system, and computer.

Features

Main technical index:

A. Measuring range: Maximam diameter: 450mm; Maximam height: 400 ~ 450mm

B. Spindle precision: High precision air-floating spindle

Roundness error: $\pm(0.025m + 0.0003m/mm \times \text{measuring height})$

axial error : $\pm(0.05m + 0.0003m/mm \times \text{radius})$

C. sensor: Type: Inductance sensor measuring range: $\pm 1mm$, $\pm 0.4mm$, $\pm 0.03mm$

resolution/measuring range: $0.03m/\pm 1mm$, $0.012m/\pm 0.4mm$, $0.001m/\pm 0.03mm$

D. Column Stroke: 400mm Omnidistance straightness error: $1m/500mm$

Straightness error in random 100mm: $0.25m/100mm$; Parallelism to spindle: $1m/300mm$

F. Software: based on WindowsXP

Main function : Measure base index such as Roundness, Cylindricity, Internal & external diameter, Concentricity, Flatness, Verticality, Eccentricity, Coaxiality, Run-out, Straightness, Total run-out, etc., Homornic analysis, Each filter band selection in 2-1500upr, File and data management, help file, etc.

Single ball vibration measuring instrument

S9500 series

Features

- This instrument can assess bearing waviness and the comprehensive performance and quality of the steel ball.
- Using speaker to monitor the ball vibration and noise .
- Another assessment way of bearing waviness measurements.
- Applicable to the measurement of steel ball comprehensive performance and quality assessment of steel ball.

Technical specification

Type	S9502	S9503	
Range(mm)	$\Phi 3 \sim \Phi 15$	$\Phi 3 \sim \Phi 15$	$\Phi 12 \sim \Phi 30$
Vibration measuring range	30 ~ 90dB	30 ~ 90dB	
Influence range	170 ~ 400Hz	170 ~ 400Hz	400 ~ 800Hz
Basis cibration	$\leq 26dB$	$\leq 26dB$	
Spindle Installation pattern	Horizon	Horizon	
Spindle speed	$830 \pm 15r/min$	$830 \pm 15r/min$	$420 \pm 15r/min$
Power	Motor	380V 50 Hz 370W	
	Electric box	220V 50 Hz	
Total weight	About 250Kg	About 300Kg	
Machine size(mm)	560x495x1310	580x480x1430	





CU Series laser roughness measuring instrument

(Ball or ring surface roughness measuring)

CU9505 ball or CU00 ring



Our corporation had been successfully developed CU series roughness Laser measuring instrument in the eighties, after ten years development, it form serialization and be widely used in the bearings industry. It had got national science and technology prize third grade and ministry of machine-building industry science and technology advancement prize, second grade. the product had achieved national patent, which is a new type of roughness measuring instrument, one of the recipients of third-country Machine-Building Industry Award and second prize of scientific and technological progress.

This series uses most innovative measuring principle of laser reflex facula theory that reflex facula core / band energy ratio is the function of the workpiece surface roughness, the correlation curve is obtained by theoretical calculate and analysed with a large number of experiments, contrasted with other measuring methods, it has more obvious advantages.

Features

- Non-contact measurement, it can not scratch the surface and can eliminate measuring error which comes from that the measuring tip can not be brought into the bottom during high-level roughness measurement, it Particularly suitable to measure the superfinish workpiece surface roughness .
- Because of the laser coherence, it enables the measuring system structure simple and eliminates inconvenience of the general interference light measuring instruments because of its small vision.
- Reasonable structure and perfect mathematical model, which greatly reduces possible error the light source due to changes in surface reflection coefficient and the external interference of different, showing the value of stable and reliable measurement of high precision.
- Advanced circuit design, automatic data collection, automatic analysis and calculation, digital direct display Ra, Ry and ball grade value, high measuring efficiency, less human error.
- Adjust apparatus is simple, easy to operate, less demanding work environment, apply to the factory and laboratory.
- CU0008, CU0013 raceway roughness laser measuring instrument are used to measure the outer/inner ring raceway surface roughness for single row radial ball bearing.

CU9505 ball roughness instrument technical specification

Measuring range	Ball diameter ϕ 4.5 ~ 70mm
Measuring range of Ra	0.005 ~ 0.32mm
Measuring range of Ry	0.01 ~ 0.32mm
Indication error	< 15%
Indication repeatability	> 95%
Efficiency	About 150 pieces/h

CU9505 ball roughness laser measuring instrument is used to measure the ball surface roughness.

CU00 series ring roughness instrument technical specification

Model	CU0008	CU0013
Size range of ring		
Outer ring: Outside diameter	ϕ 30 ~ ϕ 80mm	ϕ 40 ~ ϕ 130mm
Curvature diameter	R2.5 ~ 6.2mm	R3 ~ 9mm
Width	9 ~ 18mm	12 ~ 25mm
Inner ring: Outside diameter	ϕ 17 ~ ϕ 52mm	ϕ 23 ~ ϕ 75mm
Curvature diameter	R2.5 ~ 6.2mm	R3 ~ 9mm
Width	9 ~ 18mm	12 ~ 25mm
Roughness range of Ra	0.020 ~ 0.32 μ m	
Indication error	< 15%	
Indication repeatability	> 95%	
Efficiency	About 120 pieces/h	



Surface Shape Measuring Instrument

XZ-200



The instrument is improved on the T2450 Roller Convexity Measuring Instrument (which won the third class of Science & Technology Improvement Prize of the Ministry of Machine -Building Industry). It is a precision instrument for measuring multi-parameters of surface micro geometry structure and macro geometry profile of various machinery parts. It is widely used in machine-building industries, such as bearing, automobile, motorcycle, tool & die manufacturing and optical element manufacturing industry, etc, and in laboratories of research institutes and colleges as well as metrological departments of enterprises.

Features

- High precision linear base and roundness base e.g. precision air-floated slider or rotating workbench.
- Various accessories such as different precision sliders and rotating workbench, adjusted working table, apparatus and sensors etc. available. They can be used in multi-type of combination flexibility and high performance.
- Many measuring parameters can meet the needs of most geometric profile analysis of surface. The parameters include roughness, roundness, concentricity, cylindricity, linearity, parallelism, verticality, angle and profile, etc.
- Operation is controlled by computer, and measurement can be manual or automatic. Position error can be eliminated and measuring range can be changed automatically. The obtained profiles and parameters are directly displayed and results can be printed out.
- High performance software with friendly Chinese user interface, convenient operation and universal.

Technical specification

Range of workpiece dimensions: Diameter 3mm ~ 200mm; Length: 1mm ~200mm

Repeatability $\leq \pm 0.1\mu\text{m}$; Accuracy of table movement $\leq 0.3\mu\text{m} / 100\text{mm}$

Output: 20 ~30 pieces / hour Power 200V / 50Hz

Boundary dimension: 2100mm*800mm*1400mm

Raceway Curvature of Bearing Rings Measuring Instrument

R90 Series



Features

- The polar coordinates/radius comparing measuring method is adopted. The actual profile of measured axial section of raceway is compared with ideal circular segment by precision shafting, movable workbench and high-precision sensor.
- The high precision measuring results are clearly better than X-Y coordinates direct measuring method.
- Auto-eliminated misalignment and high calculating accuracy greatly improve the measuring accuracy, raise the measuring efficiency, simplify the operation and make adjustment more easily.
- The fine-designed measuring system with precision basic shafting, high-precision sensor, precision workbench and homogeneous no-clearance adjustment assures the high measuring accuracy and reliability.
- The sensor driven by stepper motor is started to collect data automatically, calculation and analysis also auto-run.
- The measured data and image can be shown simultaneously and printed out. It can be used in workshop check-stations and metrological laboratories.
- Usage: In grinding or superfinishing process, It can provide reliable information for processing analysis and equipment adjustment by measuring the radius of curvature of ring raceways and raceway profiles deviations.
- It can provide detailed data for quality checking and designing department by final-products bearing sample survey.

Technical specification

Range of workpiece dimensions: (R902 Type) Outer Diameter 3mm ~ 140mm; Curvature radius R2-8mm

(R903 Type) Outer Diameter mm ~ 240mm; Curvature radius R4-15mm

Repeatability (radius) $\leq \pm 5\mu\text{m}$; (Furrowed deviation) $\leq \pm 0.2\mu\text{m}$ (R902 Type) ; $\leq \pm 0.3\mu\text{m}$ (R903 Type)

Relative Error (radius) $\leq \pm 5\mu\text{m}$; (Furrowed deviation) $\leq \pm 0.2\mu\text{m}$ (R902 Type) ; $\leq \pm 0.3\mu\text{m}$ (R903 Type)

Maximum swing angle: $\leq \pm 40^\circ$ Measuring force: (R902 Type) 0.1 ~ 0.15N ; (R903 Type) 0.1 ~ 0.18N



Bearing Radial Clearance Measuring Instrument

X09J Series



Bearing radial clearance is an important indicator of bearing quality, it impacts on bearing vibration, noise and life expectancy. The instrument is the high-precision and non-load dynamic measuring instrument. The measured value is the mean clearance of finished bearing, the instrument is the standard instrument for bearing industry. X093J bearing radial clearance measuring instrument had won the second class prize of Science and Technology Improvement of the Ministry of Machine-Building Industry in China. This instrument has high rotating precision spindle, stable and reliable measuring value, high-precision inductive sensors, MCU system, automatic data collection, etc.

Features

- Measuring method accords with ISO international standard fully, no load dynamic measurement.
- Standard measuring instrument for bearing radial clearance, it is suitable for industry inspection, commodity inspection and enterprise.
- X095J: Dynamic/static/three points measuring methods etc.
manual fix/automatic load/automatic measurement;
High-precision spindle/high-precision sensor/precision measuring system.
Bearing clearance value limit setting and alarm; Separate bearings measurement

Technical specification

Model	X092J	X093JB	X094J	X095J
Instrument model	baseline			Automatically loaded
Measuring scope(mm)	bore ϕ 3-15	bore ϕ 12-50	bore ϕ 40-100	bore ϕ 90-outside ϕ 300
sensor range(μ m)	0-100,0-200		0-200,0-400	\pm 100, \pm 200, \pm 500
error & repeatability	2 μ m (\pm 1 μ m)		3 μ m (\pm 1.5 μ m)	\pm 4 μ m

Bearing Axial Clearance Measuring Instrument

X09Z Series



The axial clearance is an important index to be considered when the installation of hub bearing axial localization. And it has a certain influence on bearing vibration, life and host accuracy etc. With the higher demands of the accuracy to hub bearing users, the axial clearance of hub bearing becomes one index which should be measured to finished bearing products gradually. In order to satisfy the demands to bearing users and bearing production enterprises, Luoyang Bearing Science & Technology Co.,Ltd has designed and developed X093Z Bearing Axial Clearance Measuring Instrument. This instrument is suitable for measuring axial clearance of hub bearings and small finished ball bearings.

Features

- Manual fix/automatic load/automatic measurement.
- High-precision spindle/high-precision sensor/precision measuring system.
- Bearing clearance value limit setting and pre-alarm.
- Separable bearing measured.
- X095Z measuring instrument: Dynamic/static/three points measuring methods etc.
- X093Z measuring instrument can also test Wheel hub bearing unit.

Technical specification

Measuring scope: bore ϕ 3-50 (X093Z); bore ϕ 50-outside ϕ 300 (X095Z);
sensor range (μ m) : 0-200, 0-400 (X093Z); \pm 100, \pm 200, \pm 500 (X095Z);
Indication error (μ m): \pm 3 (X093Z); \pm 5 (X095Z);
Indication repeatability (μ m): 6 (X093Z); 10 (X095Z)



Bearing Vibration Measuring instrument

Multi-functional bearing vibration measuring instrument

S09 Series

S09C Series



S09 Series Vibration measuring instrument is divided into the bearing vibration measuring instrument and single ball vibration measuring instrument according to the type of measured products.

Vibration and noise are the most important dynamic performance of rolling bearing. The vibration value is the main sentence to comprehensive assess the quality of the bearing,

and the quality of bearing has a direct impact on the host's performance and life. So bearing vibration measuring instrument is a necessary instrument for bearings industry and users.

Bearing vibration measuring instrument is divided into acceleration-type (S series) and speed-type (SV Series) from the measuring indicators. It is mainly used in vibration measurement of deep groove ball bearings, angular contact ball bearings, cylindrical roller bearings and tapered roller bearings.

Features

- Bearing vibration measuring instrument can show the vibration value of low, medium, high and pass frequency (50 ~ 10000Hz) and single peak of vibration signals. The speakers could output "abnormal sound" simultaneously when the bearing rotating. The measurement results are in line with the bearing vibration assessment on related national technical criteria. It also can show the bearing vibration waveform when it is matched with an oscillograph.
- The spindle in mechanical part uses hydraulic sliding bearing. And there are two installation ways: vertical type and horizontal type.
- Foundation vibration: bearing vibration measuring instrument $\leq 10 \sim 15$ dB. Steel ball vibration measuring instrument ≤ 26 dB.

Technical specification

Model	S0910	S3910	S9912
Bearing bore measuring range(mm)	deep groove ball bearings $\phi 10 \sim \phi 60$	cylindrical roller bearing $\phi 10 \sim \phi 60$	Large-size bearing $\phi 65 \sim \phi 120$
Vibration measuring range(dB)	0 ~ 100	10 ~ 90	10 ~ 100
Influence range(Hz)	Low band 50 ~ 300, middle band 300 ~ 1800, high band 1800 ~ 10000, pass band 50 ~ 10000		
Rotational speed of spindle	1500 \pm 30r/min		1000 \pm 20r/min

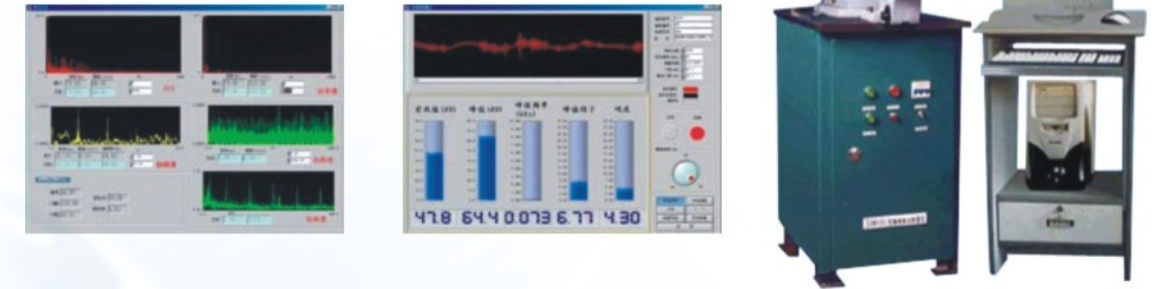

Multi-functional bearing vibration measuring instrument is the latest intelligent bearing vibration measuring instrument in our company, The system uses computer and digital signal processing technology to synthetically assess the tested signals in the time domain and frequency domain. The measurement results are in line with the bearing vibration assessment on related national technical criteria and are helpful to diagnose the quality of the measured bearing. The software system uses virtual instrument language, It analyzes and deals with all kinds of complicated parameters according to the requirements. And the instrument can provide vibration velocity and acceleration measurements at the same time. The interface is friendly, intuitive display, simple operation, high reliability and scalability features, and data can be stored and printed. This instrument is applicable to vibration detection ,abnormal sound detection and fault diagnosis (spectral analyzes of the vibration signals, Identify bearing fault location according to characteristic frequency of bearing parts, in order to control bearing quality) of deep groove ball bearings, angular contact ball bearings, cylindrical roller bearings and tapered roller bearings.

The instrument is applicable to use in measuring room of bearing factory and the measurement of bearing vibration on field, analysising and researching on bearing manufacturing process, as well as the acceptance of bearing vibration performance.

Technical specification

Measuring parameter: Vibration acceleration and velocity

Measuring range: acceleration 0 ~ 80dB, speed 0 ~ 8000m/s

Frequency response: low band 50 ~ 300Hz, middle band:300 ~ 1800Hz high band 1800 ~ 10000Hz, pass band: 50 ~ 10000Hz

Main parameter and function: virtual value, peak value, peak factor, peak frequent, kurtosis, real-time waveform, spectrum analysis chart

comprehensive basic vibration: $\leq 10 \sim 15$ dB

Bearing bore diameter: 10 ~ 16(S0910C) 65 ~ 120(S9912C)



Bearing Friction Torque Measuring Instrument

M & QM Series



Bearing friction torque is an important factor to affect noise, vibration and life of the bearing. It's the main index to determine the bearing dynamic performance. There is a series of bearing friction torque measuring instrument in our company.

(1) QM99 series bearing starting friction torque measuring instrument

This instrument is applicable to the measurement of bearing starting torque at the station of starting and low speed. It can also analysis and test the performance of bearing grease and other solid lubricant. The instrument gets the driving torque from non-contact torque sensor, monitors and controls the running of bearings by PV systems, measures bearing starting torque with high-precision measurement system. Using computer controls and finishes the measurement automatically. The measurement data of each point will be intelligent displayed and recorded automatically. The instrument performance is reliable and is easy to operate.

(2) M99 series bearing dynamic friction torque measuring instrument

The instrument is composed of mechanical parts, electrical parts and computer. It is applicable to bearing dynamic friction torque measurement (maximum friction torque, average friction torque, fluctuation value). It provides both forward and reverse measurement results and two torque curves. The results can be saved and printed. The instrument adopts the air bearing which has low-friction torque to support, and precision torque sensor. The measurement system was developed with visual and virtual instrument software. The interface is friendly, it can measure automatically and is easy to operate.

Technical specification

Model	QM9910	M9908B	M992	M695	M8930
Measuring type	ball bearing	ball bearing	ball bearing	Duplex angular	Thrust bearing
Torque type	Starting	Dynamic	Dynamic	Dynamic	Dynamic
Diameter range(mm)	d: $\phi 10 \sim \phi 50$	d: $\phi 8 \sim \phi 50$	d: $\phi 2 \sim \phi 8$	d: $\phi 10 \sim \phi 50$	d: $\phi 10 \sim \phi 50$
Torque range	20mN.m	20, 50mN.m	100 μ N.m	50 μ N.m	1000 μ N.m
Axial load	10 ~ 200N	15N	1 ~ 4N	100 ~ 500N	2000 ~ 5000N
spindle speed		5rpm	0.5, 2, 10rpm	0.5, 2, 10rpm	5 ~ 60rpm
Indication error	± 0.2 mN.m	$\pm 0.2, \pm 0.5$ mN.m	± 2.5 mN.m	± 0.5 mN.m	± 15 mN.m
Repeatability	± 0.2 mN.m	$\pm 0.2, \pm 0.5$ mN.m	± 2.5 mN.m	± 0.5 mN.m	± 10 mN.m

Bearing End-face Convexity value Measuring Instrument

T69 Series



The angular contact bearings are often used in conjunction group, in order to obtain high rigidity and high rotation accuracy, while applying rated pre-load, we also need the technical performance of the matched bearings are consistent with each other as far as possible. The matched bearings core & bearing cup end face convexity is usually taken by grinding the insulating spacer, but this operation is complicated and the actual pre-load is difficult to be controlled quantitatively, it is difficult to get the performance of bearing system reliably, and the bearing life will also be affected.

The instrument can measure the convexity value and re-entrant of angular contact bearing end-face is designed to meet the requirement for war industry. It settles the matching problem of bearings successfully. T6928 bearing convexity measuring instrument is applicable to the measurement of high-precision split inner ring angular contact bearing. This instrument had won the second prize of The State Technological Invention Award.

Features

- It can measure under rated pre-load. Reliable data. The load could be pre-set according to your need. Convenient to use.
- The system uses air bearing or high-precision rolling bearing for spindle and realizes the dynamic measurement.
- The whole system has advanced construction, high rigidity and accurate data. It is applicable to selecting matched bearings for bearing enterprise and matching host enterprise. it also can be used as a reliable research and analysis tool in specialized laboratory. and it is the essential technical support of universal matching bearing matching bearing manufactory.

Technical specification

Model	T6912	T6924	T6928
Measuring range	D: $\phi 26 \sim \phi 120$ mm	D: $\phi 90 \sim \phi 240$ mm	D: $\phi 80 \sim \phi 280$ mm
Measuring capacity	$\pm 200 \mu$ m	$\pm 200 \mu$ m	$\pm 200 \mu$ m
Indication error	$\pm 1 \mu$ m	$\pm 1.5 \mu$ m	$\pm 2 \mu$ m
Indication repeatability	$\pm 1 \mu$ m	$\pm 1.5 \mu$ m	$\pm 2 \mu$ m
Measuring Load	4 ~ 400N	20 ~ 2000N	150 ~ 15000N
Measurement Swlection	Maximum, Minimum, Random Value, Mean value		



Bearing Axial Rigidity Measuring Instrument

GD6912 Type



Rigidity is the capability of mechanical components to resist distortion when forcing on it. Its value can be obtained by measuring displacement when the part is impressed by force and become deformed. Now in domestic, there is no specialized measuring instruments for bearing rigidity, most users just calculate bearing rigidity in theory. Some others also use simple

test devices to verify and test bearing rigidity, but it can only give a number of discrete points of rigidity, rigidity curve can not be mapped. So it can not be a true reflection of the bearing rigidity.

The bearing axial rigidity measuring instrument we have developed is the specialized instrument for bearing axial rigidity. The instrument can provide the curve of bearing axial rigidity, in order to make the bearing parameter analysis easier and ensure the best rigidity of matching host.

This instrument is applicable to the factory and the laboratory.

Features

- Precision axial loading device is used in the system, it can axial load continuously and steadily. The load range is stepless adjustment between 50N and 500N.
- Precision spindle has superior motion accuracy, rigidity and steadily under certain load.
- The circuit has strong anti-jamming ability, good steadily and fast response speed.
- The test software calculates rigidity, mean rigidity according to the sampling result of force sensor and inductive displacement sensor. It also shows a rigidity curve automatically.

Technical specification

Bearing dimensions d:10 ~ 60mm D:15 ~ 100mm

Axial load: 50 ~ 500N, stepless adjustment

Load measurement precision: $\leq \pm 1\%$ Fm

Displacement resolution: 0.1m

Displacement precision: $\pm(0.5+0.01T)$ m (T is actual measuring displacement value)

Rigidity error: $\pm 5\%$

Matched bearings preload measuring instrument

YJ6912



The preload of matched bearing is a key parameter. Its accuracy affects the performance of duplex bearings directly as well as the whole host. When doing the original installation, bearing will have a certain pre-deformation. So the main role of pre-load is that making the bearings skips the initial large deformation stage. It increases the support rigidity significantly. In addition, the matched bearings are used in precision shafting which needs higher accuracy.

Matched bearings preload measuring instrument is the specialized instrument for preload measurement. The instrument can measure the preload of matched bearings quantitatively and accurately and ensure the rigidity, precision and speed of bearings are in an optimization status.

This instrument is applicable to the factory and the laboratory.

Technical specification

Measuring range: bore diameter: 10 ~ 60mm

outside diameter: < 100mm

height of bearings: < 120mm

Measuring range of pre-load: Fa=20 ~ 400N

Measuring error of pre-load: $\pm 5\%$ Fa



Multi-Parameters Bearing Bore & Outside Diameters Measuring Instrument

ZD9Q Series



This instrument is designed according to the measuring method regulated in Standard GB307.2-84. It can measure all kinds of bearings bore and outside diameter.

Features

- In the system, coreless fixtures are used to make the workpiece rotating and centering, absolute fix, easy installation.
- When measuring, workpiece rotates at an even speed, the system captures data of several points in the single plane.
- The measuring device can be moved vertically and measure on the planes of different heights according to your requirement. The number of the plane you want to measure could be preset.
- Computer-controlled, automatic measurement, automatic data processing, data display, the results can be printed and saved.
- The precision of our instrument is higher than general bore, outside diameter measuring instrument. It is applicable to measuring room of bearing factory, inspection station, bearing quality supervision and custom inspection dept.

Technical specification

Model	ZD9205Q	ZD9113Q	ZD9210Q	ZD9120Q
Measuring range(mm)	d: ϕ 10 ~ ϕ 50	d: ϕ 26 ~ ϕ 130	d: ϕ 50 ~ ϕ 100	d: ϕ 120 ~ ϕ 200
Measuring parameter	$\Delta ds, \Delta dmp, Vdp, Vdmp, \Delta Ds, \Delta Dmp, VDp, Vdmp$			
Working height	$\leq 40\text{mm}$			
Indication error	$\pm 0.5 \mu\text{m}$		$\pm 1 \mu\text{m}$	
Indecation repeatability	$\pm 0.5 \mu\text{m}$		$\pm 1 \mu\text{m}$	
Minimum plane spacing	1/8mm			
Number of planes	1 ~ 240			
Efficiency	Max. 3 pieces/min			

Precision Bearing inner and Outer Ring Running Accuracy Measuring Instrument

B Series



Running Accuracy is an important parameter to assess precision bearing quality. The instrument measuring principle meets ISO standard requirements, it is used to evaluate the quality of finished bearing. The instrument is also applicable to bearing check and acceptance for bearing manufacturers and military users.

Features

- Using high-sensitivity universal joint, the bearing ring is driven by motor system, which meets the evaluation standard of bearing industry.
- High-precision, small load inductance head, little measuring error.
- Data processing, display and printing the error curve through the computer.

Technical specification

Model	B623	B613	B625	B615
Measuring parameters	K_{ia} : Radial runout of inner ring, K_{oa} : Radial runout of outer ring, S_{ia} : Axial runout of inner ring, S_{oa} : Axial runout of outer ring.			
Measuring range(mm)	Bore diameter ϕ 10 ~ ϕ 60	Outside diameter ϕ 19 ~ ϕ 110	Bore diameter ϕ 80 ~ ϕ 160	Outside diameter ϕ 140 ~ ϕ 300
indication	$K_{ia}: \pm 0.6$	$K_{oa}: \pm 1$	$K_{ia}: \pm 1.5$	$K_{oa}: \pm 1.5$
Repeatability(μm)	$S_{ia}: \pm 1$	$S_{oa}: \pm 1.5$	$S_{ia}: \pm 1.5$	$S_{oa}: \pm 1.5$
Range(μm)	± 100			



Bearing Contact Angle Measuring Instrument

J69 Series



Contact angle is an important parameter to determine the bearing's performance, and it determines the axial and radial bearing capacity of the bearing. Large amount of theoretical researches and experiments show that the contact angle value and its consistency will directly affect the rigidity, rotating accuracy and life of the whole shafting on angular contact ball bearing for precision spindle, especially duplex bearings, Therefore more and more users have controlled this parameters strictly as a key factor which can improve the performance of precision spindle.

The contact angular measuring instrument we developed applies planetary gear train principle, namely which is that fixing inner ring, balls and outer ring rotation at a certain ratio. The ratio is a function of bearing contact angle. By setting the rotational speed of cage, the instrument measures corresponding rotational speed of outside ring. After processed by the computer, it can show the contact angle value.

This instrument is easy to operate, and has high precision and good repeatability. It is applicable to host matchment measurement or national metrology unit.

Technical specification

Model	J693	J6915	J6930
Measuring range	d: $\phi 10 \sim \phi 50\text{mm}$ D: $< \phi 30\text{mm}$	d: $\phi 26 \sim \phi 130\text{mm}$ D: $\leq \phi 150\text{mm}$	d: $\phi 50 \sim \phi 100\text{mm}$ D: $\leq \phi 300\text{mm}$
Indecation repeatability	30'	30'	30'
Measuring efficiency	30 pieces/h	30 ~ 60 pieces/h	30 pieces/h
Measuring load	1 ~ 10kg	2.5 ~ 25kg	10 ~ 60kg

Rolling bearing dynamic performance measuring instrument

BL Series



BL series rolling bearing dynamic performance measuring instrument is an mechatronics rolling bearing inspection equipment designed based on National machinery industry standards JB/T7049-93 and JB/T50093-1997. It can detect bearing vibration and temperature and assess bearing life. The instrument has reasonable design, stable performance and will not change the failure mechanism of tested bearings.

BL series rolling bearing dynamic performance measuring instrument can be added the friction torque testing function.

The instrument is suitable for the evaluation of bearing life and reliability by the users of high reliability bearings. It can provide basis for improving design, perfecting processing technology, optimizing materials, approving products.

Features

- Load is accurate and is easy to be regulate. Speed range is wide and the speed precision is high.
- Real-time monitoring of vibration, temperature and automatically data record.
- Temperature and vibration limits can be set. When the value is out of the limit, the instrument will shutdown and alarm.
- The instrument can be used via networking group control and also can be run independently offline.
- The instrument has Built-in communication interface. So it can send the experimental data to store, print, analysis.
- Test system processes data by a singlechip, It also has LCD that displays Chinese and graphic, digital filtering, photoelectric isolation and brown-out protection technology which can let the system have a long time of continuous work.

Technical specification

Model	BL8	BL15	BL30	BL60	BL120
Diameter range(mm)	d: $\phi 3 \sim \phi 8$ D: $\phi 10 \sim \phi 24$	d: $\phi 8 \sim \phi 15$ D: $\phi 24 \sim \phi 35$	d: $\phi 15 \sim \phi 30$ D: $\phi 35 \sim \phi 62$	d: $\phi 30 \sim \phi 60$ D: $\phi 62 \sim \phi 120$	d: $\phi 60 \sim \phi 120$ D: $\phi 120 \sim \phi 200$
Max speed(rpm)	15000	12000	16000	6000	5000
Max load(N)	Radial 1500	Radial 3500	Radial 8000 Axial 3500	Radial 25000 Axial 15000	Radial 98000 Axial 68600
Silding mode	grease lubrication or oil circulation				
Monitoting parameter	Standard configure: temperature, vibration; Non-standard configure				
Temperature range	0~150 °C				
Vibration range	10~100dB				
Power supply(AC)	1.1KW	1.5KW	1.5KW	2.8KW	5.5KW



Air-floating spindle

Dense-ball spindle

KD Series

MD Series

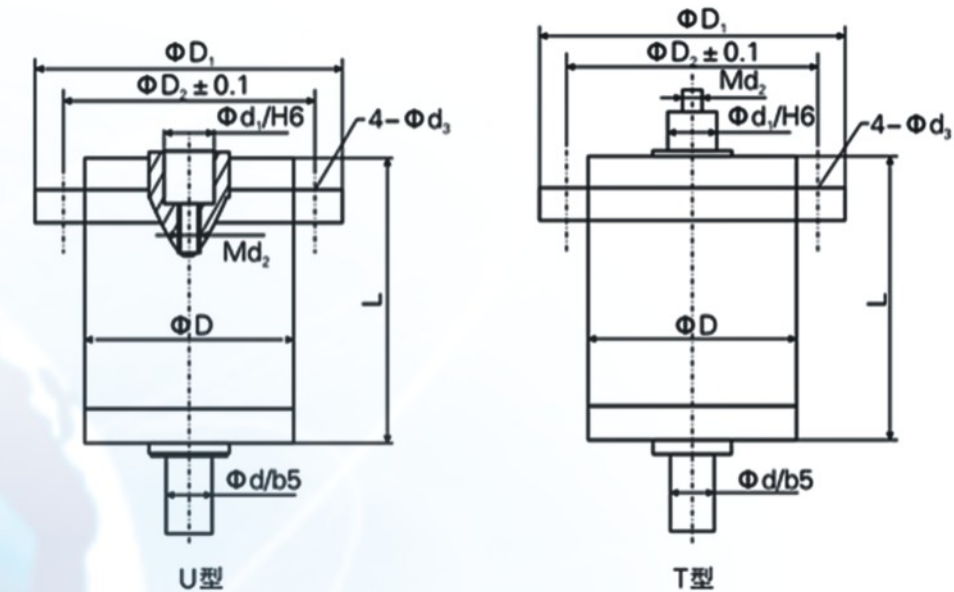
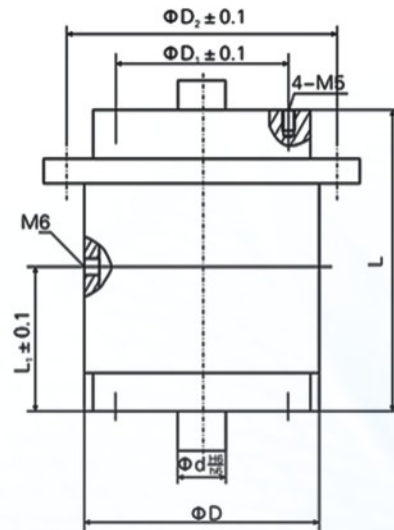

Technical specification

Technical specification

Spindle type	dimensions		Shaft assembly dimensions	Stand assembly dimensions	Axial end diameter	Air source		Accuracy of rotation (μm)
	D	L	D1	D2	d	L1	Working pressure	
KD50F	50	65	36	60	8	30	0.4~0.5MPa	≤ 0.05
KD60F	60	75	40	70	8	35		≤ 0.05
KD70F	70	90	46	80	10	45		≤ 0.05
KD80F	80	100	52	92	10	50		≤ 0.05
KD90F	90	110	62	102	20	55		≤ 0.1
KD100F	100	125	72	112	20	60		≤ 0.1
KD120F	120	150	90	136	20	75		≤ 0.1
KD140F	140	180	100	160	25	90		≤ 0.15
KD160F	160	200	120	180	25	100		≤ 0.15
KD180F	180	220	140	200	30	110		≤ 0.2
KD200F	200	250	160	220	30	125	≤ 0.2	

MD series Spindle type	MD series Spindle type	dimensions			Stand assembly dimensions			Axial input end diameter		Axial Output end diameter		Axial input end diameter (μm)
		D	L		D1	D2	D3	d	d1	d2		
MD50T	MD50U	50	70		80	65	4.5	8	8	8	≤ 0.5	
MD60T	MD60U	60	80		90	75	4.5	8	8	8	≤ 0.5	
MD70T	MD70U	70	95		110	90	5.5	10	10	8	≤ 0.5	
MD80T	MD80U	80	110		120	100	5.5	10	10	8	≤ 0.5	
MD90T	MD90U	90	120		130	110	5.5	20	20	16	≤ 0.5	
MD100T	MD100U	100	135		140	120	5.5	20	20	16	≤ 0.5	
MD120T	MD120U	120	160		160	140	5.5	20	20	16	≤ 1	
MD140T	MD140U	140	190		180	160	6.5	25	25	20	≤ 1	
MD160T	MD160U	160	220		200	180	6.5	25	25	20	≤ 1	
MD180T	MD180U	180	240		240	210	8.5	30	30	20	≤ 1.5	
MD200T	MD200U	200	260		250	230	8.5	30	30	20	≤ 1.5	

NOTE: 1. The no-flange series of air static spindle has the same dimensions with the above (no D2).
 2. The diameter of stand assembly holes and axial end length could be set according to your requirements.
 3. Above specifications and dimensions are standard series. At the same time, we can make all kinds of nonstandard product according to client's specific requirement.



CNC Internal Grinder For Ball Bearing Ring



Main feature

- Equipped with Japanese MITSUBISHI control system, the grinder can dynamically display the grinding process by using plasma touch screen.
- Feeding system is driven by MITSUBISHI servo motor & ball screw, can realize high precise faster approach & high sensitive slower feeding, the minimal resolution is 0.25 μ m.
- The speed of the oscillation mechanism is regulated through AC frequency converter.
- Equipped with MARPOSS in-process sizing gauge.
- The wheelhead & the work feeding system are equipped with high precise & preloaded cross roller guide way to ensure rigidity and long service life.
- The speed of the work spindle is regulated through frequency converter.
- Enclosed machine guard has beautiful appearance & safe function.

Technical parameter

Type	3MK203	3MK205	3MK208	3MK2016	3MK2020	3MK2030	
Processing scope	ID(mm)	$\phi 10-\phi 30$	$\phi 20-\phi 50$	$\phi 45-\phi 80$	$\phi 70-\phi 160$	$\phi 100-\phi 200$	$\phi 150-\phi 300$
	Width (mm)	8-19	12-27	16-39	24-68	30-80	40-90
Feed resolution (μ m)	0.25	0.25	0.25	0.25	0.25	0.25	
Machining accuracy (μ m)	P4						
The total power (KW)	8	10	12	20	20	22	
Dimensions (mm)	1860×1340×1760	1860×1340×1760	1860×1340×1760	2000×2040×2100	2000×2040×2100	3000×2000×2300	
Weight (kg)	3100	3100	3100	6000	6000	8000	

CNC Internal Grinder For Ball Bearing Ring

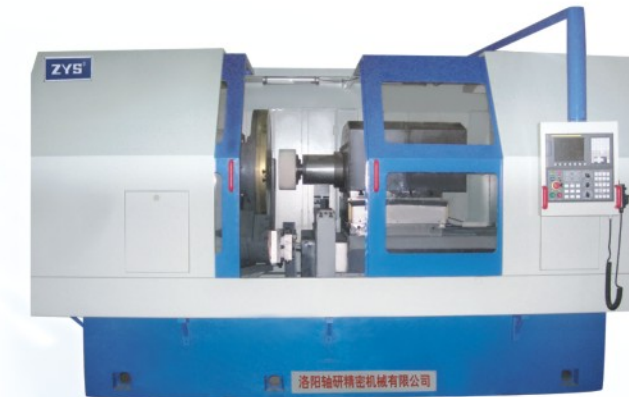

Main feature

- This type of grinder is equipped with Japanese FANUC numerical control system, and can dynamically display the grinding process by using plasma touch screen.
- Driven by MITSUBISHI servo motor & ball screw, the feeding system can realize high precise faster approach & high sensitive slower feeding.
- Grinding frame guide rail adopts high strength and preload linear motion guide rail, and has the advantages of simple structure, good rigidity, long service life.
- NN series fine grinding bearings are used in work spindle so that it can bear axial and radial cutting force, and the spindle is used in high load, heavy cutting large bearings of the strong grinding.
- Enclosed machine guard has beautiful appearance and safe function.
- The grinder can grinding taper roller and ball bearings rolling way at the same time by replacing wheel dresser.

Technical parameter

Type	3MK2040	3MK2050	3MK2080	
Processing scope	ID(mm)	$\phi 200-\phi 400$	$\phi 250-\phi 500$	$\phi 400-\phi 800$
	Width (mm)	60-150	100-200	100-300
Feed resolution (μ m)	0.5	0.5	0.5	
Machining accuracy (μ m)	P4	P4	P4	
The total power (KW)	30kw	35kw	45kw	
Dimensions (mm)	4000×2500×2200	4500×2500×2400	5000×2500×2400	
Weight (kg)	12000	14000	18000	



CNC Raceway Grinder For Ball Bearing Inner Ring



Main feature

- Equipped with Japanese MITSUBISHI control system , the grinder can dynamically display the grinding process by using Schneider touch screen.
- Feeding system is driven by MITSUBISHI servo motor & ball screw, can realize high precise faster approach & high sensitive slower feeding, the minimal resolution is 0.25 μm.
- Adopting the AC servo motion driving system, the feeding slide & the dressing slide are driven by the same ball screw to maintain the synchronism of the feeding & the dressing.

- The grinding featuring high balance precision, realizing 60m/s high speed grinding.
- The frame of the arc dresser is the whole bowed-shaped, so the dresser has good rigidity & high turning accuracy.
- The feeding & the dressing system are equipped with high precise & preloaded cross roller guideway to ensure rigidity and long service life.
- Enclosed machine guard has beautiful appearance & safe function.

Technical parameter

Type	3MK131	3MK135	3MK1310	3MK1320	3MK1330	
Processing scope	ID(mm)	φ5-φ10	φ10-φ50	φ50-φ100	φ100-φ200	φ150-φ300
	Width (mm)	5-10	8-27	12-45	20-50	40-80
Machining accuracy (μm)	P4	P4	P4	P4	P4	
Feed resolution (μm)	0.25	0.25	0.25	0.25	0.25	
The total power (KW)	10	12	18	20	25	
Dimensions (mm)	1700×1350×1900	1840×1565×1730	2300×1700×1800	2600×1700×2050	3000×1700×2050	
Weight (kg)	3000	3500	5000	7000	10000	

CNC Raceway Grinder For Ball Bearing Outer Ring



Main feature

- Equipped with Japanese MITSUBISHI control system , the grinder can dynamically display the grinding process by using Schneider touch screen .
- Feeding system is driven by servo motor & ball screw, can realize high precise faster approach & high sensitive slower feeding, the minimal resolution is 0.25 μm.

- The wheelhead & the workpiece feeding system are equipped with high precise & preloaded cross roller guideway to ensure rigidity and long service life.
- The speed of the workpiece spindle is regulated through frequency converter.
- The wheel dresser can use either high precise swing cylinder or motor to drive arc dress mechanism, and has high dressing precision.
- Enclosed machine guard has beautiful appearance & safe function.

Technical parameter

Type	3MK143	3MK147	3MK1410	3MK1412	3MK1420	3MK1430	
Processing scope	OD(mm)	φ18-30	φ35-72	φ60-100	φ75-120	φ100-200	φ150-300
	Width (mm)	6-10	10-29	14-25	16-29	18-45	20-60
Feed resolution (μm)	0.25	0.25	0.25	0.25	0.25	0.25	
Machining accuracy (μm)	P4	P4	P5	P5	P5	P5	
The total power (KW)	10	12	12	14	18	20	
Dimensions (mm)	1860×1340×1760	1860×1340×1760	1860×1340×1760	1860×1340×1760	2000×1700×2100	3000×2000×2300	
Weight (kg)	3100	3100	3100	3150	4500	10000	



CNC Outer Raceway Grinder For Tapered Roller Bearing



Main feature

- This type of grinder is equipped with Japanese MITSUBISHI servo control system with color display , and has fault self-diagnosis function.
- Centerless grinding machine layout,plunge-cut grinding technology.
- Using high power electric spindle belonging to GDZ series.
- The feeding&the wheel dressing compensation system are driven by AC servo motor&ball screw.
- The dresser is driven by AC servo motor,dressing the wheel with the interpolation method,enable grind the crown of the groove according to the customer.
- Centralized lubrication system provides timing quantitative lubrication of ball screws.
- Enclosed machine guard ensure the machines safe.

Technical parameter

Type	3MK238	3MK2310	3MK2316	3MK2320	3MK2330	
Processing scope	Maximum outer diameter (mm)	φ80	φ100	φ160	φ200	φ300
	Maximum width (mm)	27	36	48	50	60
Machining accuracy (μ m)	P4、P5	P4、P5	P4、P5	P4、P5	P4、P5	
Dimensions (mm)	1720×1030×1820	1720×1030×1820	1760×1150×1870	2000×1700×2100	3000×2000×2300	
The total power (KW)	12	12	14	20	30	

CNC Inner Raceway Grinder For Tapered Roller Bearing



Main function

These model grinders are mainly applied to grinding inner raceway of taper roller bearing&double. single row cylindrical roller bearing.

Main feature

- The machine is controlled by MITSUBISHI control system from Japan.
- Equipped with touch screen,easily operating & having self-diagnosis function.
- The layout of the machine is centerless & the grinding technology is plunge-cut.
- Electromagnetic centerless fixture is used for holding the workpiece,the work drive is speed-various through frequency converter.
- Hydrostatic dynamic spindle bearing equipped with in-process wheel balancer.
- The feeding & the wheel dress system are both driven by AC servo motor & ball screw. The wheel dresser which dresses the wheel with the interpolation method , enable grind the crown of groove.
- Automatic loading & unloading manipulators make the operation easy.
- Equipped with flushing system , the machine is easy to keep clean.
- Enclosed machine guard has beautiful appearance&safe fitaction.

Technical parameter

Type	3MK216	3MK2110	3MK2116	3MK2120	3MK2130
ID(mm)	φ17-φ60	φ50-φ100	φ80-φ160	φ90-φ200	φ150-φ300
Width(mm)	12-40	20-70	30-80	40-110	50-110
Workhead rotation angle	0-30°	0-30°	0-30°	0-30°	0-30°
Machining accuracy (μ m)	P4、P5				
The total power (KW)	15	18.5	22	25	35
Weight (kg)	3500	5500	5800	6500	10000



CNC Rib Grinder For Tapered Roller Bearing Inner Ring



Main feature

- Equipped with Japanese MITSUBISHI control system , the grinder can dynamically display the grinding process by using plasma touch screen.
- Feeding system is driven by AC servo motor & ball screw , can realize high precise faster approach & high sensitive slower feeding .
- Adopting the AC servo motion driving system , the feeding slide & the dressing slide are droved by the same ball screw to maintain the synchronism of the feeding&the dressing.
- The wheel is equipped with balancer , featuring high balance precision , realizing 60m/s high speed grinding.
- The flame of the arc dresser is the whole bowedshaped , featuring good rigidity & high turning accuracy.
- The feeding & the dressing system are equipped with high precise & preloaded cross roller guideway to ensure rigidity and long service life.
- Enclosed machine guard has beautiful appearance & safe function.

Technical parameter

Type	3MK226	3MK2210	3MK2220	3MK2230	
Processing scope	ID(mm)	φ10-φ50	φ50-φ100	φ100-φ200	φ150-φ300
	Width(mm)	8-27	12-45	20-50	40-80
Machining accuracy (μ m)	P4	P4	P4	P4	
Feed resolution (μ m)	0.25	0.25	0.25	0.25	
The total power (KW)	12	18	20	25	
Dimensions (mm)	1840×1565×1730	2300×1700×1800	2600×1700×2050	3000×1700×2050	
Weight (kg)	3500	5000	7000	10000	

CNC Raceway Grinder For Thrust Ball Bearing



Main feature

- The machine applies high precise & preloaded cross roller guideway.
- The feeding of the workpiece frame and the reciprocation of the grind-ing frame are both driven by MR AC servo motor & ball screw.
- Using high rigidity electric spindle , the speed of which is regulated through frequency converter.
- Using the sleeve type work spindle , the speed of which is regulated through frequency converter.
- Using swinging loading and unloading paers , using electromagnetic centerless fixture for locating the workpiece.
- Equipped with Japanese PLC control system and touch display screen , featuring easily operating and self-diagnosis function.
- Enclosed machine guard.

Technical parameter

Type	3MK108B	3MK1012B	3MK1020B
OD(mm)	φ25-80	φ60-120	φ100-200
Machining accuracy (μ m)	P4	P4	P4
Feed resolution (μ m)	0.25	0.25	0.25
The total power (KW)	10	12	16
Dimensions (mm)	1700×1350×1900	1700×1350×1900	2300×1700×1800
Weight (kg)	3100	3150	4500



Semi-Automatic Miniature Multipurpose Grinder



Main feature

- This type of grinder adopts numerical control system for grinding, and can realize manual discharging & charging, dressing the wheel automatically (arc wheel is dressed manually).
- The feeding & the oscillating system are equipped with ball screw & cross roller guideway, and are driven by servo motor.
- The grinder is controlled by PLC, using the touch screen for displaying the grinding process, featuring self-dianosis function.
- Using high power electric spindle belonging to GDZ series, the speed of the work spindle is regulated through frequency converter, electromagnetic centerless fixture is used.
- Enclosed machine guard ensure safe use & beautiful apparent.

Technical parameter

- Processing range:(mm)
- Grinding internal diameter: $d = \phi 3 \sim \phi 40$
- Grinding width: $B_{max} = 30$
- Grinding outer diameter: $D_{max} = \phi 52$
- Attention: can improve the design according to the customers.

Outline dimensions 1400x1000x1600

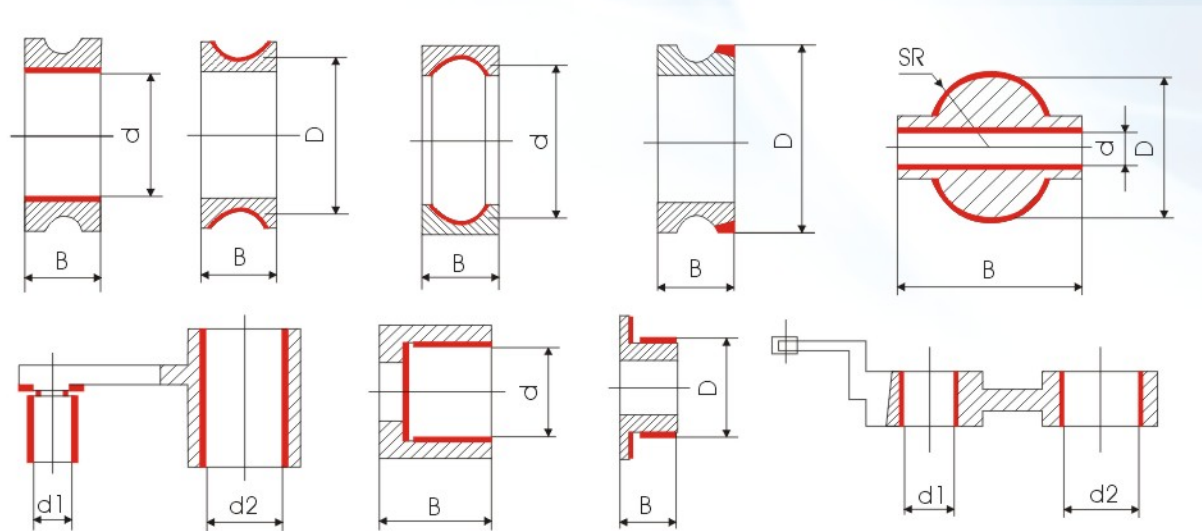

Automatic Raceway Superfinishing Machine For Ball Bearing Inner Ring



Main feature

- The machine is controlled by Japanese MITSUBISHI control system.
- Two working stations layout, each of them can perform rough & fine finishing process separately or both work at the same time.
- The speed of the work and oscillating motors are respectively regulated through AC frequency converter.
- Using centering axis to orientate. clamping the endface.
- Featuring automatically compensating the oilstone.
- Forced charging & discharging mechanism feature high efficiency & good stability.
- Enclosed machine guard ensure the machines safe and beautifl.

Technical parameter

Type	3MZ311	3MZ315	3MZ3110	
Processing scope	ID(mm)	$\phi 5-10$	$\phi 10-50$	$\phi 50-100$
	Width(mm)	5-10	8-27	12-45
Roundness Improvement	>15-20%	>15-20%	>15-20%	
The total power (KW)	4.5	5	7	
Dimensions (mm)	1450x1400x1900	1800x1450x2000	1800x1600x2000	
Weight (kg)	1300	1800	2500	



Automatic Raceway Superfinishing Machine For Ball Bearing Outer Ring



Main feature

- The machine is controlled by Japanese MITSUBISHI control system.
- Two working stations layout, each of them can perform rough & fine finishing process separately or both work at the same time.
- The speed of the work and oscillating motors are respectively regulated through AC frequency converter.
- Choosing centerless fixture, the supporting can preset outside.
- Featuring automatically compensating the oilstone.
- Forced charging & discharging mechanism feature high efficiency & good stability.
- Enclosed machine guard ensure the machines safe and beautiful.

Technical parameter

Type	3MZ323	3MZ329	3MZ3216	
Processing scope	OD(mm)	φ12-30	φ35-70	φ80-160
	Width(mm)	5-10	8-27	12-45
Roundness Improvement	>15~20%	>15~20%	>15~20%	
The total power (KW)	4	5	5	
Dimensions (mm)	1450×1400×1900	1500×1100×1800	2100×1600×2000	
Weight (kg)	1800	1800	1800	

CNC Raceway Superfinishing Machine For Angular Contact Ball Bearing



Applications

The machine is semiautomatic groove superfinishing machine for angular contact ball bearing rings, which is applied to superfinish 6th, 7th kinds of inner or outer bearing ring groove with P4 class accuracy class.

Main feature

- Adopt the semiautomatic two-step processing technology of using single end for rough or finish processing.
- Implemented with PLC control system and touch screen, the system is reliable and easy to operation.
- The speed of the workpiece axis and the oscillation are regulated through AC frequency converter.
- Using centreless jig, clamping the end.
- Enable individually adjusts the pressure of rough and finish processing.
- Enclosed machine shield avoids revealing the superfinishing fluid.

Technical parameter

Type	3MB3010	3MB3020	3MB3030	
Processing scope	The outer ring OD (mm)	φ50-φ65	φ100-φ200	φ200-φ300
	The Inner ring ID (mm)	φ10-φ65	φ20-φ110	φ100-φ200
	Contact angle adjustment range	0-40°	0-40°	0-40°
Machining accuracy (μm)	P4	P4	P4	
Dimensions (mm)	2000×1210×1700	2000×1700×2100	2000×1700×2100	
Weight (kg)	3500	4500	4500	



CNC Raceway Grinder For Automobile Hub Bearing Inner Ring

Product model: 3MK1310-GL

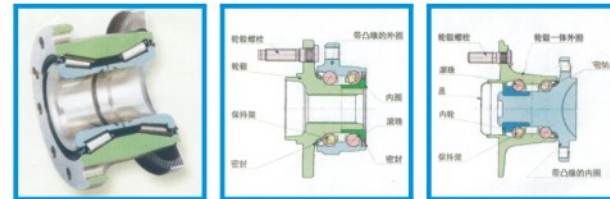

Main purposes

It is used for grinding inner raceways of 1st, 2nd and 3rd generations auto-hubs bearing (grinding the raceway, mouth diameter and small faces simultaneously)

Main Structures and Features

- Adopting japan MITSUBISHI full digital AC servo control system.
- Centerless layout, fixed wheel support feeding and compensating with dresser automatically.
- With diamond roller dresser.
- High rigidity, high precision dynamic and static pressure spindle are used and rotating at high-speed without touching between shaft diameter and sleeve in order to realize to realize to grind at 60m/s high speed.
- Compulsive manipulator can automatically load and unload which is reliable and easy for adjustment.
- Electromagnetic centerless clamps are used for the grinder, and speed of the workpiece shaft can be adjustable by variable frequency.

Main specifications and processing accuracy level

- | | |
|--|--|
| • Workpiece O.D.(mm) $\phi 50 - \phi 120$ | • Concentricity(mm) 0.003 |
| • Workpiece width(mm) 20-50 | • Parallelism from bottom of groove(mm) 0.002 |
| • Dimension deviation(mm) ± 0.008 | • Roughness allowance 0.30-0.50 |
| • Roundness(mm) 0.002 (O.D. roundness ≤ 0.001 mm) | • Cycle time (taking DAL4074 - C/01 as an example): 55-65 sec/piece. |
| • Groove parallelism(mm) 0.005 | |
| • Roughness Ra(um) 0.32 | |

CNC Raceway Grinder For Automobile Hub Bearing Outer Ring

Product model: 3MK1412-GL

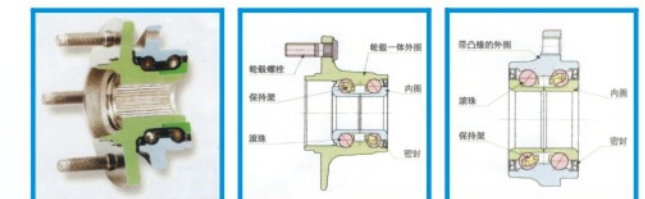

Main purposes

It is mainly used for grinding outer raceways of 1st, 2nd and 3rd generations and double-row angular contact ball bearings.

Main Structures and Features

- Adopting Japan MITSUBISHI full digital AC servo-control system.
- Electromagnetic centerless clamps are used for the grinder and speed of workpiece shaft can be adjustable by frequency variable: a micro-adjusting device is equipped with workpiece support.
- The spindle is used for wheel with variable speed in order to realize to grind at 60m/s high speed.
- With diamond roll dresser.
- Compulsive manipulator can automatically load and unload which is reliable and easy for adjustment.

Main specifications and processing accuracy level

- | | |
|---|--|
| • Workpiece O.D.(mm): $\phi 50 - \phi 120$ | • Concentricity(mm): 0.003 |
| • Workpiece width(mm): 20-50 | • Parallelism from bottom of groove(mm): 0.002 |
| • Dimension deviation(mm): ± 0.008 | • Roughness allowance: 0.30-0.50 |
| • Roundness(mm): 0.002 (O.D. roundness ≤ 0.001 mm) | • Cycle time (taking DAL4074 - C/01 as an example): 55-65 sec/piece. |
| • Groove parallelism(mm): 0.005 | |
| • Roughness Ra(um): 0.32 | |



CNC Raceway Superfinishing Machine For Tapered Roller Bearing



Main feature

- This type of grinder is equipped with Japanese FANUC numerical control system, and can dynamically display the grinding process by using Schneider touch screen.
- Oilstone oscillation system adopts servo motor drive, which has small reciprocating, big shocks, so it can improve the accuracy and meet the roller's protruding degree requirements after grinding, and has high precise and good stability .
- Workpiece axis adopts sleeve structure, which is simple, reliable, high precision, and the axis bearings use ZYS precise bearings.
- The guide rail which adopts super-precision, preload cross roller guide rail, has good rigidity and long service life.
- Enclosed machine guard has beautiful appearance and safe function.

Technical parameter

Type		3MZ3310	3MZ3320	3MZ3420	3MZ3430
Processing scope	ID(mm)	φ25-φ60	φ70-φ150	φ40-φ100	φ100-φ200
	Width(mm)	20-40	30-60	20-40	30-60
Resolution		0.25	0.25	0.25	0.25
Machining accuracy (μ m)		P4	P4	P4	P4
The total power (KW)		10kw	15kw	10kw	18kw
Dimensions (mm)		1840×1565×1730	2300×1800×2000	1840×1565×1730	2300×1800×2000
Weight (kg)		2800	4800	2800	4800

Cold Precision Rolling Machine



Main function

Cold rolling technique is one of the plastic shaping processing methods which on the normal temperature extrude, and stretch the ring parts. It features refining blanks quality, reducing cutting, optimizing the structure, improving the bearing life.

Main feature

With the level layout, the machine has cold rolling and plastic two positions. The machine has two working patterns; one is simultaneously cold rolling and plastic motion, the other is cold rolling or plastic motion respectively. The machine uses PLC control system; the workpiece size control system and the position of main sliding block are detected by optical grating. The machine is droved by hydraulic pressure, featuring cold rolling and plastic pressure detection and protection. The machine has stable mechanical structure Human machine interface adopts large scale color touch screen, which is convenient for interchanging between human and machine, and enable store the technical parameters of 20 types parts.

The novel researching PCR type of open cold rolling machine applies combinational modal mechanism, using computer for realtime displaying and controlling rolling process, adopting the new technologies of active measurement and proportional servo system. The PCR type has not only the advantage of international same kind type but also the unique features, having high adaptive ability to the blanks, easily and rapidly to operating and regulating.

Technical parameter

Type	PCR-72	PCR-90	PCR-120	PCR-160
Rolling pressure(KN)	80	120	200	240
Maximum outer diameter (mm)	72	100	120	160
Minimum inner diameter (mm)	20	25	60	100
Maximum width (mm)	25	40	45	60
Spindle speed(rpm)	100	160	160	140
Feeding speed (mm/s)	0-100	0-30	0-30	0-6
Main motor power (KW)	5.5	7.5	15	22
Hydraulic motor power (KW)	3	4/5.5	4/7.5	4/7.5
Rolling -cooling oil motor power (W)	250	250	250	250
Lubricating volume (L)	2	2	2	2
Hydraulic oil volume (L)	160	250	250	250
Rolling oil volume (L)	100	120	120	120
Height (mm)	1500	1950	1800	2000
Area (mm)	1800×1300	2000×1800	2360×2000	2360×1800
Weight (kg)	2600	4000	5000	5500



CNC Raceway Grinder For Automobile Hub Bearing Inner Ring

Product model: 3MK1310-GL

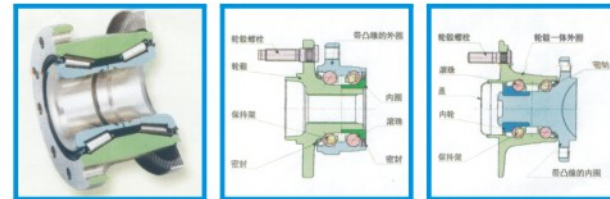

Main purposes

It is used for grinding inner raceways of 1st, 2nd and 3rd generations auto-hubs bearing (grinding the raceway, mouth diameter and small faces simultaneously)

Main Structures and Features

- Adopting japan MITSUBISHI full digital AC servo control system.
- Centerless layout, fixed wheel support feeding and compensating with dresser automatically.
- With diamond roller dresser.
- High rigidity, high precision dynamic and static pressure spindle are used and rotating at high-speed without touching between shaft diameter and sleeve in order to realize to realize to grind at 60m/s high speed.
- Compulsive manipulator can automatically load and unload which is reliable and easy for adjustment.
- Electromagnetic centerless clamps are used for the grinder, and speed of the workpiece shaft can be adjustable by variable frequency.

Main specifications and processing accuracy level

- | | |
|---|---|
| • Workpiece O.D.(mm) : $\phi 50 - \phi 120$ | • Concentricity(mm): 0.003 |
| • Workpiece width(mm): 20-50 | • Parallelism from bottom of groove(mm): 0.002 |
| • Dimension deviation(mm): ± 0.008 | • Roughness allowance: 0.30-0.50 |
| • Roundness(mm): 0.002(O.D.roundness ≤ 0.001 mm) | • Cycle time(taking DAL4074 - C/01 as an example): 55-65 sec/piece. |
| • Groove parallelism(mm): 0.005 | |
| • Roughness Ra(um): 0.32 | |

CNC Raceway Grinder For Automobile Hub Bearing Outer Ring

Product model: 3MK1412-GL

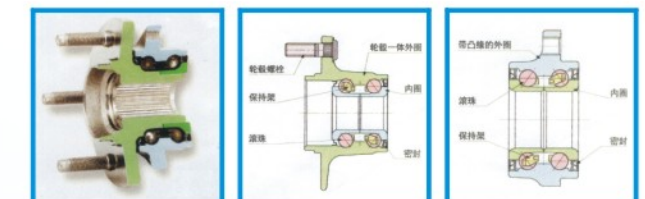

Main purposes

It is mainly used for grinding outer raceways of 1st, 2nd and 3rd generations and double-row angular contact ball bearings.

Main Structures and Features

- Adopting Japan MITSUBISHI full digital AC servo-control system.
- Electromagnetic centerless clamps are used for the grinder and speed of workpiece shaft can be adjustable by frequency variable: a micro-adjusting device is equipped with workpiece support.
- The spindle is used for wheel with variable speed in order to realize to grind at 60m/s high speed.
- With diamond roll dresser.
- Compulsive manipulator can automatically load and unload which is reliable and easy for adjustment.

Main specifications and processing accuracy level

- | | |
|---|---|
| • Workpiece O.D.(mm): $\phi 50 - \phi 120$ | • Concentricity(mm): 0.003 |
| • Workpiece width(mm): 20-50 | • Parallelism from bottom of groove(mm): 0.002 |
| • Dimension deviation(mm): ± 0.008 | • Roughness allowance: 0.30-0.50 |
| • Roundness(mm): 0.002(O.D.roundness ≤ 0.001 mm) | • Cycle time(taking DAL4074 - C/01 as an example): 55-65 sec/piece. |
| • Groove parallelism(mm): 0.005 | |
| • Roughness Ra(um): 0.32 | |



CNC Grinder Special For Sewing Machine Rotating Shuttle Components



Main feature

- This type of grinder is equipped with Japanese FANUC numerical control system, and can dynamically display the grinding process by using Schneider touch screen.
- Driven by MITSUBISHI servo motor & ball screw, the

feeding system can realize high precise faster approach & high sensitive slower feeding.

- Adopting the AC servo motion driving system, the feeding slide and the dressing slide are respectively drove by the ball screw drive, which ensure the drive chain separately.
- The wheel uses static balancer, which ensure high precision balance, and make the grinder realize 60m/s high speed grinding.
- The grinder adopts grinding wheel dresser ,which is equipped with ZYS precision distribution , that has high precision and good stability.
- The feeding and the dressing system are both equipped with high precise and preloaded cross roller guide-way to ensure rigidity and long service life.
- Enclosed machine guard has beautiful appearance and safe function.

Technical parameter

Type		3MK133BS	3MK147BS	3MK205BS
Processing scope	ID(mm)	φ15-φ30	φ25-φ50	φ25-φ50
	Width(mm)	3-10	3-10	5-20
Feed resolution (μ m)		0.25	0.25	0.25
Machining accuracy (μ m)		P4	P4	P4
The total power (KW)		10kw	12kw	12kw
Dimensions (mm)		1840×1565×1730	1840×1565×1730	1840×1565×1730
Weight (kg)		4000	3000	3500

CNC Automatic Production Line For Small Ball Bearing



Main feature

- Processing range: 6201-6209
- Processing accuracy: P5 class. accuracy reserve ratio is over 80%
- Total power: 60KW

Main feature

- Implemented with CNC equipment in production line, the feed slide is driven by AC servo motor&ball screw. the display is plasma touch screen, and equipped with constant power adaptive control system.
- Use MARPOSS inprocess sizing gauge.
- The data of the sizing machine mounted outside is feedback to the machine feeding system to automatically control the size.
- High rigidity&high power electric spindle is used with oil-air.
- Enable auto inprocess dynamic balancing.
- Having tele-monitoring,tele-diagnosis & communication function.
- Auto avoiding collision&guaranteeing the quality of the bearing.
- The apparent of the whole auto line is beautiful colorful & delightful,the auto line is also easily to operate&change.

Technical parameter

Name	RACEWAY GRINDER FOR INNER RING	INTERNAL GRINDER FOR RING	RACEWAY GRINDER FOR OUTER RING	RACEWAY SUPERFINISHING MACHINE FOR INNER RING	RACEWAY SUPERFINISHING MACHINE FOR OUTER RING	ID POST-PROCESS GAUGING MACHINE	FEEDING MACHINE	HOIST	ONLINE DEVICE (CRAWLER)
Model	3MK135	3MK205	3MK147	3MZ315D	3MZ329D	RJZK205D	SIJ001	TSJ001	DEMAGNETIZATION
Number	1	1	1	1	1	1	2	5	3
Processing scope	Outer diameter:D=φ50-φ100		Inner bore:d=φ10-φ50		width:B=8-27				
The total power (KW)	47								
Area (mm)	Inner Ring Production Line:11700×2400				Outer Ring Production Line :7000×2400				
Weight (kg)	20								



CNC Automatic Line for Tapered Roller Bearing

Name	INNER RACEWAY GRINDER	INTERNAL GRINDER	RIB GRINDER FOR INNER RING	OUTER RACEWAY GRINDER	INNER CEWAY SUPER-FINISHING MACHINE	OUTER RACEWAY SUPER-FINISHING MACHINE	ID POST-PROCESS GAUGING MACHINE	FEEDING MACHINE	HOIST	ONLINE DEVICE (CRAWLER)
Model	3MK216	3MK206	3MK226	3MK2312	3MZ3310	3MZ3410	RJZK206D	SIJ001	TSJ001	DEMAGNETIZATION
Number	1	1	1	1	1	1	1	2	6	4
Processing scope	Outer diameter:D=φ60-φ120			Inner bore:d=φ20-φ60			width:B=15-45			
The total power (KW)	65									
Area (mm)	Inner Ring Production Line:13700×2400					Outer Ring Production Line :7000×2400				
Weight (kg)	25									

Precision Machine Component Parts



High-speed precision angular contact ball bearings

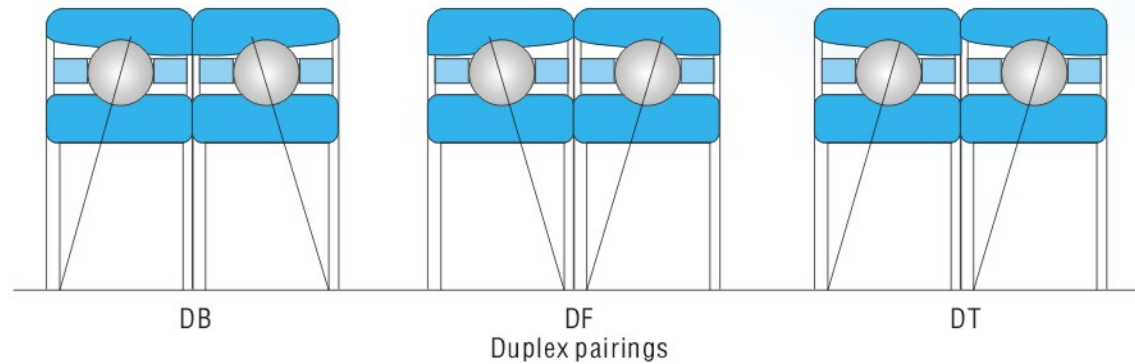

High-speed precision angular contact ball bearings

- Bearing identification code
- 718、719、70、72 Series
- H719、H719/HQ1、H70、H70/HQ1 Series
- B70、B70/HQ1 Series
- HS719、HS719/HQ1、HS70、HS70/H Q 1 Series
- B719-2RZ、B719-2RZ/HQ1、B70-2RZ、B70-2RZ/HQ1 Series
- Comparison table of angular contact ball bearings with other makers

High precision ball screw bearings

- Ball screw bearing identification code
- ISO Metric
- Non-ISO Metric
- Inch
- Comparison table of ball screw bearings with other makers

Technical parameter

Type	MOTOR PARAMETERS					Dimensions (mm)						Shaft End to Rod Join Size mm				Bearing C/P4 Level Accuracy	Grinding wheel D3 mm	Old Type
	Power KW (S6) (S1)	Voltage V	Current A (S6) (S1)	Rotating Speed r/min	Frequency HZ	D	L	D1	L1	D2	L2	D1	L1	M	L2			
120MD51Q8	8 4.8	350	20 12	51000	850	120	232	80	30	23	10	14	23	M14×1.5	19	2-B7005 2-B7004	24	2GDZ51Q
120MD51Y8	8 4.8	350	20 12	210000	850	120	250	70	12	23	13	14	23	M14×1.5	19	2-B7005 2-B7004	24	2GDZ51
120MD51Y6.5	6.5 3.9	350	17 10.2	51000	850	120	325	70	12	23	6.5	14	24	M14×1.5	18	2-B7005 2-B7004	22	2GDZ51N
120MD48Y5.8	5.8 3.5	350	15 9	48000	800	120	230	80	23	23	14	14	24	M14×1.5	19	2-B7005 2-B7004	22	GDZ48
120MD42Y9	9 5.5	350	20 12	42000	700	120	230	90	27	23	12	14	24	M14×1.5	19	2-B7005 2-B7004	22	GDZ42S
120MD36Y8.5	8.5 5	350	18 11	36000	600	120	255	92	30	28	12	16	27	M16×1.5	20	2-B7006 2-B7005	30	GDZ36B
120MD36Y8.5C	8.5 5	350	18 11	36000	600	120	255	92	28	33	15	20	34	M20×1.5	20	2-B7007 2-B7005	30	GDZ36C
120MD30Y11	11 6.6	350	30 17.8	30000	1000	120	315	70	10	33	7	20	34	M20×1.5	19	2-B7007 2-B7006	38	2GDZ30N
120MD24Z5.5	5.5 3.3	350	18 11	24000	400	120	255	92	30	28	12	16	27	M16×1.5	20	2-B7006 2-B7005	50	GDZ24K
120MD24Y12	12 7.2	350	30 18	24000	800	120	315	70	10	43	8	22	38	M22×2	24	2-B7009 2-B7006	48	2GDZ24N
150MD36YY11	11 7	350	30 15.6	36000	600	150	270	105	32	33	14	20	34	M20×1.5	20	2-B7007 2-B7006	34	2GDZ36
150MD24Y12.5	12.5 7.5	350	26.7 16	24000	400	150	310	98	32	38	19	22	38	M22×2	26	2-B7008 2-B7007	45	GDZ24A