

BEARINGS FOR WIND TURBINE GENERATORS



# 风电轴承

洛阳轴研科技股份有限公司  
洛阳轴承研究所有限公司

LUOYANG BEARING SCIENCE AND TECHNOLOGY CO.,LTD.  
LUOYANG BEARING RESEARCH INSTITUTE CO.,LTD.

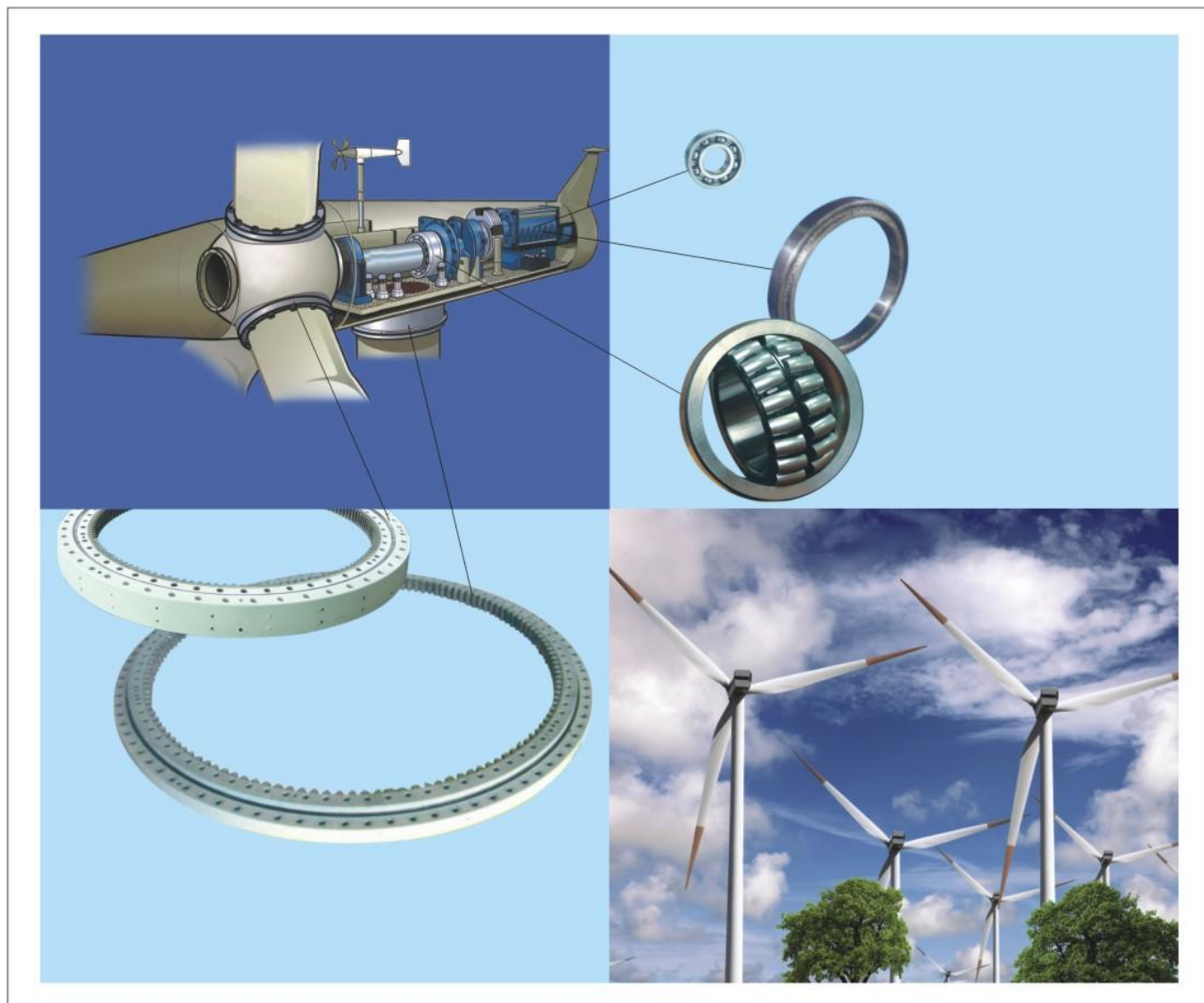



## 公司简介

洛阳轴研科技股份有限公司的前身洛阳轴承研究所是中国轴承行业唯一的国家一类综合性研究所，始终保持着滚动接触理论、轴承设计、制造、材料、试验及信息标准等方面的综合优势，占据着航空航天、舰船兵器、矿山冶金、风力发电、机床工具、机械装备用精密轴承、轴承工业成套装备及检测仪器、电主轴等研究、开发、试验的领先地位，为中国轴承行业开创了众多的国内先河。

公司是中国航空轴承领域的领军企业，圆满完成了我国航天发展史上具有里程碑意义的第一颗“东方红”人造地球卫星，“神州一号”到“神州七号”系列载人飞船，“嫦娥”探月工程的轴承及组件的配套任务。2001年，改制成立洛阳轴研科技股份有限公司，2005年在深圳证券交易所挂牌上市，简称“轴研科技”，股票代码：002046。目前，轴研科技已形成以研发中心为科技创新基地，第一和第二产业园为产业化基地的“产、学、研”结合的科研生产布局。曾荣获“中国驰名商标”、“河南省50户高成长型高新技术企业”、“全国知识产权示范先进单位”、“国家高新技术工作突出贡献奖”、“国机集团‘十五’时期突出贡献奖”、“2009《福布斯》中国最具潜力企业200强”等荣誉称号。

2001年，公司首家承担了国家科技部“大中型风力发电机组关键轴承开发”项目，系列掌握了风力发电机偏航和变桨转盘轴承、风叶主轴轴承、齿轮箱和发电机轴承设计、制造及检测等方面的核心技术与知识产权；培养了中国第一个风电轴承专业博士后，开发出可进行风力发电机轴承载荷谱分析，应力分析、关键结构参数设计校核、有效淬火热硬化层深度计算、齿轮和螺栓强度校核等功能的集成专业设计分析软件；造就了一大批风电轴承设计、性能分析、加工以及检测的专业人员，生产的风电轴承产品性能指标达到国际先进水平。截至目前，已申报了“1.0MW风力发电机转盘轴承”、“1.5MW风力发电机转盘轴承”、“一种自润滑转盘轴承保持架”、“一种长寿命、高承载三排滚子组合转盘轴承”、“基于物联网下的智能风力发电机轴承”等有关风力发电机轴承的国家专利。尤其是独家申请的“基于物联网下的智能风力发电机轴承”获国家发明专利，可实现风力发电机系统关键轴承的远程实时监控、故障预警和故障诊断。

公司一直十分重视科技成果的产业化，大力推进产业化生产规模，先后建成了以特种精密轴承、电主轴、轴承工艺装备产业为主的第一产业园和以重型精密机械轴承产业为主的第二产业园。第二产业园占地面积近200亩，总投资4.38亿元，配置数控立式车床、数控插齿机床、高速数控铣齿机床、高速数控钻孔机床、数控表面淬火机床、进口数控立式磨床等一大批高、精、尖设备。产品可以满足风电、盾构、矿山、冶金、港口吊装、工程机械、军工等多个领域高精度、高品质轴承的需求。

## INTRODUCTION

As a scientific and technological enterprise, Luoyang Bearing Science and Technology Co., Ltd has comprehensive advantages in contact theory of rolling bearing, bearing design, production, materials, testing and bearing standards and etc. It is in the leading position in research, development and testing in the following areas: aerospace, spaceflight, ship weapon, mining, metallurgy, machine tools, precision bearing for machinery and equipment, bearing assembly, measuring instrument, electrical spindle and etc. The company is the pioneer of numerous technology and relevant theories in bearing industry in China.

The company is the leading enterprise in aerospace bearing industry of China and it has successfully accomplished the task of bearing assemblies for “Dongfanghong-1”, the first man-made satellite of China, manned spacecraft series from “Shenzhou I” to “Shenzhou VII” and “Chang’ E” moon exploration project. In 2001, based on Luoyang Bearing Research Institute, the unique first-class comprehensive research institute in Chinese bearing industry, Luoyang Bearing Science and Technology Co. Ltd was established and then listed at Shenzhen Stock Exchange in 2005 with stock code 002046. Our registered trademark is “ZYS”. At present, a structure that combines research and production has been formed. The R&D center carries out the work of technology innovation and the First and Second Industrial Park conducts production. The company has successively won many honors such as: well-known trademark of China, Top 50 high-growth high-tech enterprises of Henan Province, advanced units in the national intellectual property rights, award for outstanding contributions to the national high-tech work, the outstanding contribution award during the 10th five-year plan of China by National Machinery Industry Corporation, China's top 200 promising companies in Forbes 2009.

In 2001, the company became the first company that undertook the project of National Ministry of Science and Technology - “Development of key bearings for large and medium wind turbine generator”. The company has acquired the core designing, manufacturing and testing technology in yaw bearing, pitch bearing, main bearing, gearbox, and generating motor bearing in wind turbine system. We have also cultivated a number of professional staff in wind bearing design, property analyses, manufacturing and testing. We cultivated the first post doctor in the field of wind power generator in China and developed specialized integrated design and analysis software that can conducts load spectrum analysis of wind turbine generator bearing, stress analysis, design and verification of key structural parameters, calculation of effective hardened layer depth and gear and bolt strength check etc. Properties of our wind turbine generator bearings have reached international advanced level. Up to now, we have applied many national patents in wind turbine generator bearing such as “slewing bearing for 1.0MW wind turbine generator”, “slewing bearing for 1.5MW wind turbine generator”, “self-lubricating cage for slewing bearing”, “long life, high load three row roller combination slewing bearing”, and “Intelligent wind turbine generator bearing based on Internet of things” etc. In particular, the exclusive patent of “Intelligent wind turbine generator bearing based on internet of things” can realize remote monitoring, fault warning and diagnosis.

The company always highly values the application of technology achievements in actual production, also pays high attention to the improvement of scientific and technical innovation. We have enlarged the production scale in recent years. We established the First Industrial Park, which produces special precision bearing, electrical spindle, bearing process equipment, and the Second Industrial Park, which produces large size heavy duty precision bearings. Our Second Industrial Center covers an area of 133,333 m<sup>2</sup> and the total investment is 438 million RMB. We have a large batch of precision and advanced equipments like CNC vertical lathes, CNC gear shapers, high-speed CNC cutting machines, high-speed CNC drilling machines, CNC hardening machines and imported CNC vertical grinders etc. We can produce high quality and high precision bearings and our bearings are used in the fields of wind power mining, tunnel boring machine, metallurgy, harbor hoisting, general mechanical engineering and military defense etc.

# 目 录

## CONTENT

	<b>偏航、变桨转盘轴承代号方法</b> Bearing code for yaw and pitch bearing	01
	<b>偏航、变桨转盘轴承结构型式</b> Structure of yaw and pitch bearing	03
	<b>技术要求</b> Technical requirement	04
	<b>偏航和变桨轴承外形尺寸</b> Dimension of yaw and pitch bearing	07
	<b>专用偏航、变桨转盘轴承的外形尺寸、适用机型</b> Dimension and application of special yaw and pitch bearing	09
	<b>齿轮箱轴承</b> Gearbox bearing	19
	<b>主轴轴承</b> Spindle bearing	21
	<b>用户调查表</b> Application questionnaire	22



## 一、偏航、变桨转盘轴承代号方法 Bearing code for Yaw and Pitch Bearing

### 1.1代号的构成

轴承代号由基本代号和后置代号组成。

### 1.1 Bearing code composition

Generally, slewing bearing code is consisted of basic code and suffix.

### 1.2基本代号构成

基本代号分为三部分，前部为结构型式和传动型式代号，中部为滚动体直径，后部为滚动体中心圆直径。

### 1.2 Basic code composition

Basic code includes three parts. The front part is numbers indicating bearing structure and drive mode, middle part stands for rolling element diameter and back part is the pitch circle diameter.

#### 1.2.1.1结构型式代号

结构型式代号按表1的规定。

#### 1.2.1.1 Bearing structure code

Bearing structure code is indicated in table 1.

表1 结构型式代号  
Table 1 Bearing structure code

结构型式代号 Bearing structure code	结构型式 Bearing structure
01	单排四点接触球轴承 Single-row ball slewing ring Four-point contact bearing
03	双排四点接触球轴承 Double-row ball slewing ring Four-point contact bearing

#### 1.2.1.2传动型式代号

传动型式代号按表2的规定。

#### 1.2.1.2 Drive mode code

Drive mode is indicated in table 2.

表2 传动型式代号  
Table 2 Drive mode number

传动型式代号 Drive mode code	传动型式 Drive mode
0	无齿式 Without gear
1	渐开线圆柱齿轮外齿较小模数 Involute spur external gear with smaller module
2	渐开线圆柱齿轮外齿较大模数 Involute spur external gear with bigger module
3	渐开线圆柱齿轮内齿较小模数 Involute spur inner gear with smaller module
4	渐开线圆柱齿轮内齿较大模数 Involute spur inner gear with bigger module

#### 1.2.1.3基本代号编制规则

基本代号编排时，结构型式代号和传动型式代号连写，前部、中部和后部之间用“.”隔开。

#### 1.2.1.3 Rule of basic code

Use “.” to inoculate the front part, middle part and back part, in which the front part includes bearing structure and drive mode.

### 1.2.2后置代号

#### 1.2.2 Suffix

#### 1.2.2.1后置代号排列顺序

后置代号是在轴承的材料及热处理方式、公差等级、尺寸、

#### 1.2.2.1 Suffix sequence

Suffix is of numbers behind basic code when bearing material and

密封、技术要求等有改变时，在基本代号后添加的补充代号，其排列按表3。

heat treatment, tolerance grade, size, seal and technical requirement change, as listed in Table 3.

表3 后置代号排列顺序  
Table 3 Suffix

1	2	3	4
轴承材料 Bearing material	密封、套圈变型、技术要求等 Sealing, ring deforming, technical requirements and etc.	公差等级 Tolerance grade	齿轮改变 Gear alter

### 1.2.2.2 后置代号含义及编制规则

1.2.2.2.1 风电轴承的材料为42CrMo，热处理方法为调质处理，代号为“03”，在其代号前用“.”和基本代号隔开。

1.2.2.2.2 当密封、套圈变形或技术要求等有变化时，用“K和数字”表示，如“K1”，“K2”等。其代号与材料代号空半个汉字距。

1.2.2.2.3 公差等级分为0、6、5三级，从前到后依次升高。在其代号前用“/”与前面代号分开，公差等级为0级时，可不标注。

### 1.2.3 代号示例

### 1.2.2.2 Drawing rule of postpositive number and its indication

1.2.2.2.1 For bearings in wind turbine generator, their material is 42CrMo. Generally, their heat treatment is hardening and tempering treatment, which can be represented by code “03”. The code “03” should follow the basic number with “.”.

1.2.2.2.2 When sealing, ring deforming or technical requirement change, use “K+number”, for example “K1”, “K2”, which is inoculated by “blank”, behind material and heat treatment code to indicate these changes.

1.2.2.2.3 Tolerance grade is divided into Grade 0, 6 and 5 whose precision is increasing accordingly. The code is inoculated with the front code by “/”. If grade is 0, 0 can be omitted.

### 1.2.3 Bearing code example

03 3 . 40 . 1900 . 03 K1

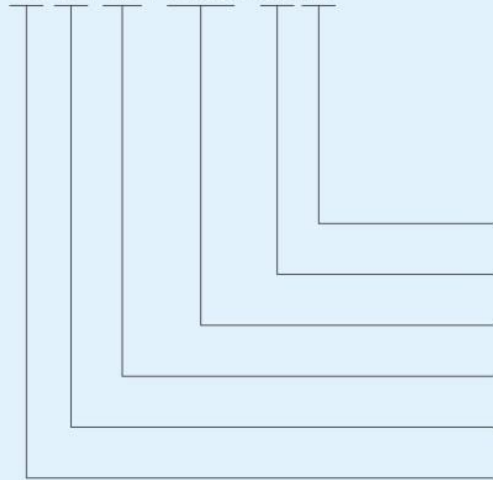

密封结构改变

Sealing structure changes

材料为42CrMo，调质处理

Bearing material is 42CrMo, hardening and quenching

滚道中心圆直径为1900

Pitch circle diameter is 1900 mm

滚动体直径为40

Rolling element diameter is 40 mm

内齿较小模数

Internal gear with smaller module

双排四点接触球转盘轴承

Double-row ball bearing slewing ring four-point contact bearing



## 二、偏航和变桨轴承结构型式 Structure of Yaw and Pitch Bearing

偏航和变桨轴承通常采用单排四点接触球转盘轴承、双排四点接触球转盘轴承。按其是否带齿及齿所在的位置又分为无齿式、内齿式和外齿式。

Generally, yaw and pitch bearing structures are single row ball slewing rings four-point contact bearing and double row ball slewing ring four-point contact bearing. And both these two types of bearings can be further divided into bearings without gears, bearings with internal gears, bearings with outer gears according to gear position.

### 2.1 单排四点接球转盘轴承

Single row ball slewing rings four point contact ball bearing

### 2.2 双排四点接触球转盘轴承

Double row ball slewing ring four-point contact bearing

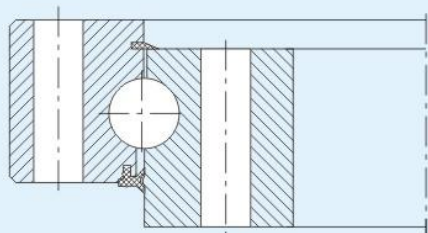

无齿式  
Without gear

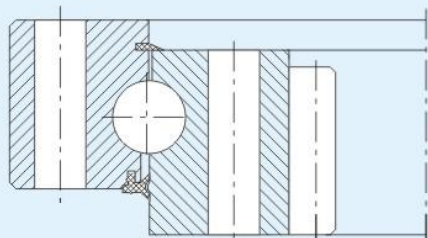

内齿式  
With internal gear

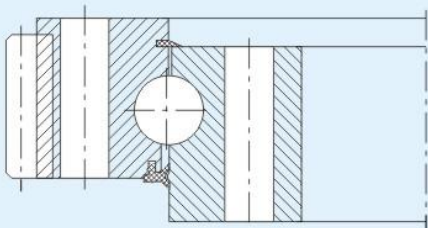

外齿式  
With outer gear

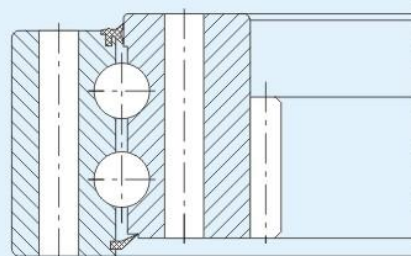

内齿式  
With internal gear

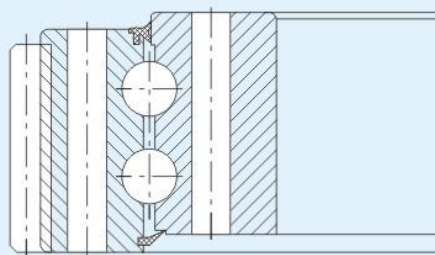

外齿式  
With outer gear

### 三、技术要求 Technical requirement

#### 3.1 材料与热处理

偏航和变桨转盘轴承的滚动体一般采用符合GB/T 18254-2002规定的GCr15或的GCr15SiMn轴承钢制造。其热处理质量符合JB/T 1255-2001规定，也可采用性能相当或更优的其它材料。

偏航和变桨转盘轴承的套圈一般采用符合GB/T30771999规定的42CrMo，也可采用满足性能要求的其他材料。套圈的低温冲击功要求：-40℃ AKV不小于27J。

偏航和变桨转盘轴承的套圈探伤不低于GB/T 7736-2001中的Ⅱ级要求。调质后硬度为229HB~269 HB或由供需双方协商确定，滚道表面淬火硬度55HRC~62 HRC。滚道淬火后有效硬化层深度应符合表4 的规定。

#### 3.1 Material and heat treatment

Rolling elements in yaw and pitch bearing are made of GCr15 or GCr15SiMn bearing steel according to GB/T 18254-2002. Their heat treatment should comply with JB/T 1255-2001. Other materials with similar or better properties can also be used.

The material of rings in yaw and pitch bearing is 42CrMo or others that meets technique requirements according to GB/T3077-1999. The value of notched bar impact work shall be no less than 27J at -20°C, for -30°C according to agreements.

Rings of yaw and pitch bearing should be applied magnetic particle testing with requirement stricter than Grade II according to GB/T 7736-2001. Hardness after hardening and quenching should be 229HB~269HB, for raceway after quenching 55HRC~62HRC. The effect hardened thickness of raceway should meet the requirement in Table 4.

表4 套圈滚道有效硬化层深度 $D_s$ 值  
Table 4 Raceway effect hardened thickness  $D_s$

(毫米mm)

$D_w$	超过 >	-	30	40	50
		到 ≤	30	40	50
$D_s$	≥3.0		≥3.5	≥4.0	≥5.0

注： $D_s$ 值为硬度≥48HRC的滚道表层深度      Note:  $D_s$  is the depth of groove surface with hardness ≥ 48 HRC

偏航和变桨转盘轴承套圈的软带宽度不应大于柱塞孔直径加35mm。软带一般应置于柱塞孔的滚道位置。

The width of soft area should not be larger than plug diameter+35 mm. Soft area should be positioned at the groove of the plug.

#### 3.2 偏航和变桨转盘轴承套圈齿轮

偏航和变桨转盘轴承套圈齿轮一般是渐开线圆柱齿轮，齿轮径向变为系数 $x=+0.5$ ，也可根据需要取其它变位系数。齿轮模数应符合GB/T 1357-1987的规定。齿轮精度不低于GB/T 10095.1-2001和GB/T 10095.2-2001中规定的998GK的要求。

#### 3.2 Gear in yaw and pitch bearing

Gear in yaw and pitch bearing usually is involute cylindrical gear with radial modification coefficient  $x=+0.5$  or other values. Gear modulus should meet GB/T 1357-1987. Gear precision should be no lower than 998GK of GB/T 10095.1-2001 and GB/T 10095.2-2001.

#### 3.3 公差与游隙

偏航转盘轴承的轴向、径向游隙值一般为0~50  $\mu\text{m}$ ，也可根据用户需要进行调整。

变桨转盘轴承的轴向、径向游隙值小于0。

偏航和变桨转盘轴承尺寸公差按表5规定。

#### 3.3 Tolerance and clearance

Generally radial and axial clearance of yaw bearing is 0~50  $\mu\text{m}$ . They can be adjusted according to customer requirement. Radial and axial clearance of pitch bearing is less than 0. Tolerance of yaw and pitch bearing is listed in Table 5.



表5 尺寸公差

Table 5 Tolerance

(微米  $\mu\text{m}$ )

da或Da mm da or Da		$\Delta T_s$	$\Delta d_s$			$\Delta D_s$		
		公差等级 Tolerance Grade						
超过 >	到 $\leq$	0、6、5	0	6	5	0	6	5
400	630	$\pm 800$	H9	H8	H7	h9	h8	h7
630	1000	$\pm 1000$						
1000	1600	$\pm 1200$						
1600	2000	$\pm 1400$						
2000	2500	$\pm 1600$	H10	H9	H8	h10	h9	h8
2500	4500	$\pm 1800$						

a  $\Delta T_s$ 、 $\Delta d_s$ 按d查表,  $\Delta D_s$ 按D查表  
a  $\Delta T_s$ 、 $\Delta d_s$  according to d,  $\Delta D_s$  according to D  
b 非定位直径的 $\Delta d_s$ 、 $\Delta D_s$ 可分别按H12或h12的规定  
b For non positioning diameter,  $\Delta d_s$ 、 $\Delta D_s$  shall be H12 or h12

旋转精度按表6的规定。

Rotating precision is listed in Table 6.

表6 旋转精度

Table 6 Rotating precision

(微米  $\mu\text{m}$ )

da或Da mm da or Da		Sia、Sea			Kia、Kea			Fria、Frea		
		Max								
		公差等级 Tolerance Grade								
超过 >	到 $\leq$	0	6	5	0	6	5	0	6	5
400	630	160	80	55	220	110	80	340	250	180
630	1000	200	100	70	280	140	100	420	280	220
1000	1600	250	120	90	360	180	120	480	360	250
1600	2500	320	160	110	450	220	160	630	420	320
2500	4500	400	200	140	560	280	200	750	560	420

a 内圈或外圈旋转精度值, 应分别按内径d或外径D查表  
a For inner or outer ring rotating precision value, refer to d or D respectively  
b 轴承D或d不作定位直径时, 其Kia和Kea可分别不予要求  
b When D or d is not positioning diameter, no requirement of Kia and Kea may be all right

## 3.4 启动摩擦力矩

请与我公司技术部门协商确定。

## 3.4 Starting torque

Please consult with Technique Department of our company.

## 3.5 润滑油孔

偏航和变桨转盘轴承通过油孔进行润滑, 注油孔为螺纹孔, 其规格为M10  $\times$  1。

## 3.5 Lubrication hole

Yaw and pitch bearing is lubricated through lubrication hole, which is screwed hole with M10  $\times$  1.

### 3.6 密封

风力发电机偏航和变桨转盘轴承的密封圈材料一般采用符合HG/T 2811-1996规定的丁腈橡胶。我公司生产的风力发电机偏航和变桨转盘轴承全部采用国外知名品牌的密封圈，性能优良，品质可靠。

### 3.7 隔离块与保持架

我公司生产的风力发电机偏航轴承，其内部采用具有自润滑效果的隔离块，这种隔离块的优点是：当轴承内部润滑脂分布不均匀时，可以补偿润滑，使钢球与滚道接触区时刻处于最佳的润滑状态。

我公司生产的风力发电机变桨轴承，其内部采用整体式钢板保持架，这种保持架的优点是：结构简洁，节省空间，可以容纳更多的钢球，从而提高轴承的承载能力，另外，与传统分段式保持架相比，整体式结构不仅更易于装配，而且运行更加平稳，可靠。

### 3.8 防腐处理

偏航和变桨转盘轴承除滚道和齿轮部分外，其它表面按照GB/T 9793-1997和GB/T 8427-1996的规定进行热喷涂防腐处理，镀锌时防腐涂层厚度不小于160 μm，也可采用满足主机性能要求的其它防腐方法。

### 3.9 其它要求

如有其它特殊要求，可与我公司协商确定。

### 3.6 Seal

For yaw and pitch bearing, seal material should be NBR according to HG/T 2811-1996 or better material.

We use world famous seal with good performance and reliable quality for our pitch and yaw bearing.

### 3.7 Spacer and cage

Yaw bearing of our company has spacers that are self-lubricated and can compensate for lubrication when lubrication oil is unevenly distributed in order to maintain best lubrication status between balls and groove contact areas.

Our pitch bearing uses integrated steel cage which has simple structure and can save space and accommodate more balls to increase load capacity. Compared with traditional segmented cage, integrated cage is easier to assemble and more stable and reliable.

### 3.8 Preservative treatment

For yaw and pitch bearing, except for groove and gear all other surfaces should be applied thermal spraying anti-corrosion treatment according to GB/T 9793-1997 and GB/T 8427-1996. When applied zinc coating, the thickness of anti-corrosion should be no less than 160 μm. Other anti-corrosive treatment shall be applied if it meets performance requirements of the machine.

### 3.9 Other requirement

If there are other special requirements, please contact with us.



**四、偏航和变桨轴承外形尺寸 Dimension of yaw and pitch bearing**



表7 四点接触球轴承外形尺寸 Dimensions of single row four point contact ball slewing bearing (毫米mm)

基本代号 Basic Code			外形尺寸 Dimension										齿轮参数 Gear Parameter		外齿参数 External Gear		内齿参数 Internal Gear	
无齿式 Without Gear	外齿式 Outer Gear	内齿式 Inner Gear	D	d	T	D <sub>1</sub>	d <sub>1</sub>	d <sub>n</sub>	n	H	h	b	m	D <sub>a</sub>	z	d <sub>a</sub>	z	
010.30.560	011.30.560	013.30.560	662	458	80	626	494	18	20	70	10	60	5	689	135	427	86	
	012.30.560	014.30.560											6	688.8	112	428.4	72	
010.30.630	011.30.630	013.30.630	732	528	80	696	564	18	24	70	10	60	6	772.8	126	494.4	83	
	012.30.630	014.30.630											8	774.4	94	491.2	62	
010.30.710	011.30.710	013.30.710	812	608	80	776	644	18	24	70	10	60	6	850.8	139	572.4	96	
	012.30.710	014.30.710											8	854.4	104	571.2	72	
010.40.800	011.40.800	013.40.800	922	678	100	878	722	22	30	90	10	80	8	966.4	118	635.2	80	
	012.40.800	014.40.800											10	968	94	634	64	
010.40.900	011.40.900	013.40.900	1022	778	100	978	822	22	30	90	10	80	8	1062.4	130	739.2	93	
	012.40.900	014.40.900											10	1068	104	734	74	
010.40.1000	011.40.1000	013.40.1000	1122	878	100	1078	922	22	36	90	10	80	10	1188	116	824	83	
	012.40.1000	014.40.1000											12	1185.6	96	820.8	69	
010.40.1120	011.40.1120	013.40.1120	1242	998	100	1198	1042	22	36	90	10	80	10	1298	127	944	95	
	012.40.1120	014.40.1120											12	1305.6	106	940.8	79	
010.45.1250	011.45.1250	013.45.1250	1390	1110	110	1337	1163	26	40	100	10	90	12	1449.6	118	1048.8	88	
	012.45.1250	014.45.1250											14	1453.2	101	1041.6	75	
010.45.1400	011.45.1400	013.45.1400	1540	1260	110	1487	1313	26	40	100	10	90	12	1605.6	131	1192.8	100	
	012.45.1400	014.45.1400											14	1607.2	112	1195.6	86	
010.45.1600	011.45.1600	013.45.1600	1740	1460	110	1687	1513	26	45	100	10	90	14	1817.2	127	1391.6	100	
	012.45.1600	014.45.1600											16	1820.8	111	1382.4	87	
010.45.1800	011.45.1800	013.45.1800	1940	1660	110	1877	1713	26	45	100	10	90	14	2013.2	141	1573.6	113	
	012.45.1800	014.45.1800											16	2012.8	123	1574.4	99	
010.60.2000	011.60.2000	013.60.2000	2178	1825	144	2110	1891	33	48	132	12	120	16	2268.8	139	1734.4	109	
	012.60.2000	014.60.2000											18	2264.4	123	1735.2	97	
010.60.2240	011.60.2240	013.60.2240	2418	2065	144	2350	2131	33	48	132	12	120	16	2492.8	153	1990.4	125	
	012.60.2240	014.60.2240											18	2498.4	136	1987.2	111	
010.60.2500	011.60.2500	013.60.2500	2678	2325	144	2610	2391	33	56	132	12	120	18	2768.4	151	2239.2	125	
	012.60.2500	014.60.2500											20	2776	136	2228	112	
010.60.2800	011.60.2800	013.60.2800	2987	2625	144	2910	2691	33	56	132	12	120	18	3074.4	168	2527.2	141	
	012.60.2800	014.60.2800											20	3076	151	2528	127	
010.75.3150	011.75.3150	013.75.3150	3376	2922	174	3286	3014	45	56	162	12	150	20	3476	171	2828	142	
	012.75.3150	014.75.3150											22	3471.6	155	2824.8	129	
010.75.3550	011.75.3550	013.75.3550	3776	3322	174	3686	3414	45	56	162	12	150	20	3876	191	3228	162	
	012.75.3550	014.75.3550											22	3889.6	174	3220.8	147	
010.75.4000	011.75.4000	013.75.4000	4226	3772	174	4136	3864	45	60	162	12	150	22	4329.6	194	3660.8	167	
	012.75.4000	014.75.4000											25	4345	171	3660	147	

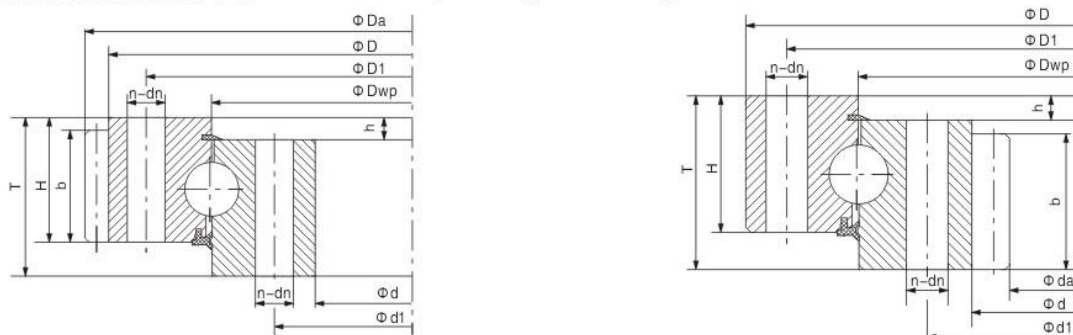

表8 双排四点接触球轴承外形尺寸 Dimensions of double row four point contact ball bearing (毫米mm)

基本代号 Basic Code			外形尺寸 Dimension									齿轮参数 Gear Parameter		外齿参数 External Gear		内齿参数 Internal Gear	
无齿式 Without Gear	外齿式 Outer Gear	内齿式 Inner Gear	D	d	T	D <sub>1</sub>	d <sub>1</sub>	d <sub>n</sub>	n	H	h	b	m	D <sub>a</sub>	z	d <sub>a</sub>	z
030.25.560	031.25.560	033.25.560	676	444	110	640	480	18	20	100	26	60	5	704	138	417	84
	032.25.560	034.25.560											6	706.8	115	410.4	69
030.25.630	031.25.630	033.25.630	746	514	110	710	550	18	24	100	26	60	6	790.8	129	482.4	81
	032.25.630	034.25.630											8	790.4	96	475.2	60
030.25.710	031.25.710	033.25.710	826	594	110	790	630	18	24	100	26	60	6	862.8	141	560.4	94
	032.25.710	034.25.710											8	862.4	105	555.2	70
030.30.800	031.30.800	033.30.800	942	658	130	898	702	22	30	120	29	80	8	982.4	120	619.2	78
	032.30.800	034.30.800											10	988	96	614	62
030.30.900	031.30.900	033.30.900	1042	758	130	998	802	22	30	120	29	80	8	1086.4	133	715.2	90
	032.30.900	034.30.900											10	1088	106	714	72
030.30.1000	031.30.1000	033.30.1000	1142	858	130	1098	902	22	36	120	29	80	10	1198	117	814	82
	032.30.1000	034.30.1000											12	1197.6	97	796.8	67
030.30.1120	031.30.1120	033.30.1120	1262	978	130	1218	1022	22	36	120	29	80	10	1318	129	924	93
	032.30.1120	034.30.1120											12	1317.6	107	916.8	77
030.40.1250	031.40.1250	033.40.1250	1426	1074	170	1374	1126	26	40	160	39	90	12	1497.6	122	1012.8	85
	032.40.1250	034.40.1250											14	1495.2	104	1013.6	73
030.40.1400	031.40.1400	033.40.1400	1576	1224	170	1524	1272	26	40	160	39	90	12	1641.6	134	1156.8	97
	032.40.1400	034.40.1400											14	1649.2	115	1153.6	83
030.40.1600	031.40.1600	033.40.1600	1776	1424	170	1724	1476	26	45	160	39	90	14	1845.2	129	1349.6	97
	032.40.1600	034.40.1600											16	1852.8	113	1350.4	85
030.40.1800	031.40.1800	033.40.1800	1976	1624	170	1924	1676	26	45	160	39	90	14	2055.2	144	1545.6	111
	032.40.1800	034.40.1800											16	2060.8	126	1542.4	97
030.50.2000	031.50.2000	033.50.2000	2215	1785	200	2149	1851	33	48	188	47	120	16	2300.8	141	1702.4	107
	032.50.2000	034.50.2000											18	2300.4	125	1699.2	95
030.50.2240	031.50.2240	033.50.2240	2455	2025	200	2389	2091	33	48	188	47	120	16	2540.8	156	1942.4	122
	032.50.2240	034.50.2240											18	2552.4	139	1933.2	108
030.50.2500	031.50.2500	033.50.2500	2715	2285	200	2649	2351	33	56	188	47	120	18	2804.4	153	2203.2	123
	032.50.2500	034.50.2500											20	2816	138	2188	110
030.50.2800	031.50.2800	033.50.2800	3015	2585	200	2949	2651	33	56	188	47	120	18	3110.4	170	2491.2	139
	032.50.2800	034.50.2800											20	3116	153	2488	125
030.60.3150	031.60.3150	033.60.3150	3428	2872	240	3338	2962	45	56	224	56	150	20	3536	174	2768	139
	032.60.3150	034.60.3150											22	3537.6	1058	2758.8	126
030.60.3550	031.60.3550	033.60.3550	3828	3272	240	3738	3362	45	56	224	56	150	20	3936	194	3168	159
	032.60.3550	034.60.3550											22	3933.6	176	3176.8	145
030.60.4000	031.60.4000	033.60.4000	4278	3722	240	4188	3812	45	60	224	56	150	22	4395.6	197	3616.8	165
	032.60.4000	034.60.4000											25	4395	173	3610	145

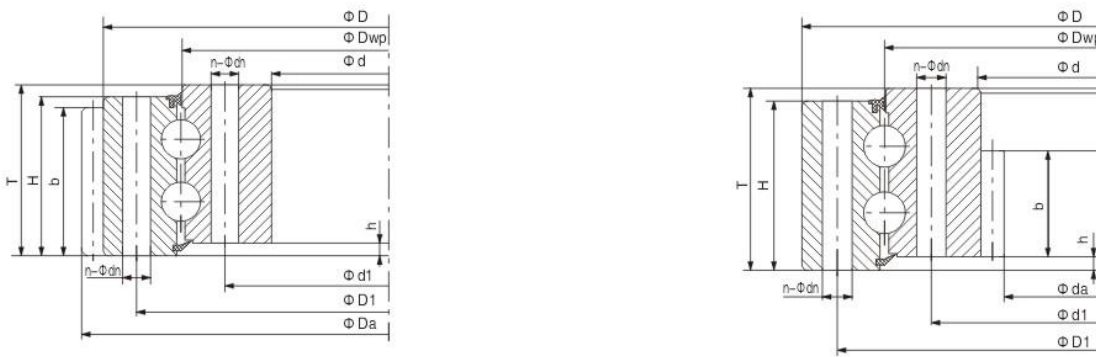

## 五、专用偏航、变桨转盘轴承的外形尺寸、适用机型及安装部位

### Dimension and application of special yaw and pitch bearing

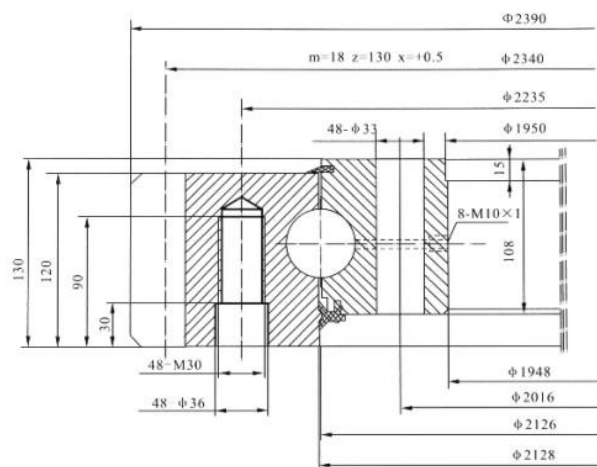

型号 Bearing Model	ZYS-011.50.2126.03
外型尺寸 Dimension	$\phi 1948 \times \phi 2390 \times 130$
轴承结构形式 Bearing Structure	单排四点接触球外齿式转盘轴承 Single-row four-point contact ball slewing bearing with external gear
适用风机及部位 Application	1.25MW风机 偏航轴承 1.25MW WTG Yaw bearing

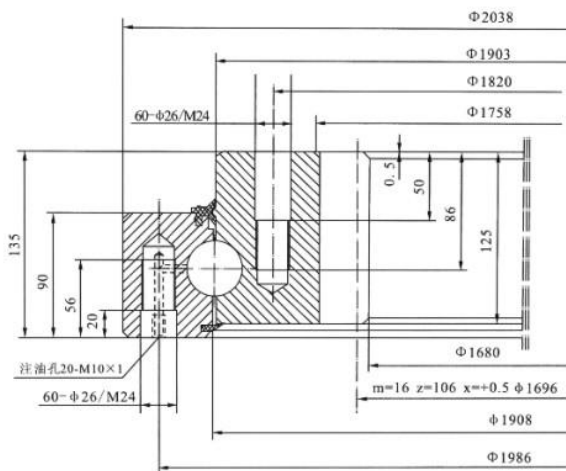

型号 Bearing Model	ZYS-013.40.1905.03
外型尺寸 Dimension	$\phi 1680 \times \phi 2038 \times 135$
轴承结构形式 Bearing Structure	单排四点接触球内齿式转盘轴承 Single-row four-point contact ball slewing bearing with internal gear
适用风机及部位 Application	1MW风机 偏航轴承 1MW WTG Yaw bearing

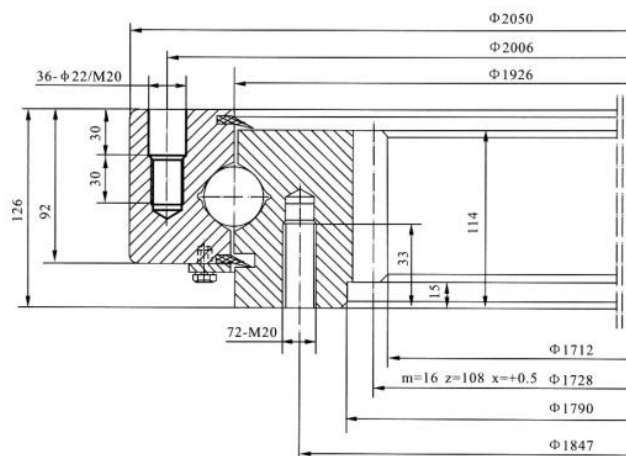

型号 Bearing Model	ZYS-013.40.1926.03
外型尺寸 Dimension	φ 1712 × φ 2050 × 126
轴承结构形式 Bearing Structure	单排四点接触球内齿式转盘轴承 Single-row four-point contact ball slewing bearing with internal gear
适用风机及部位 Application	750kW 风机 偏航轴承 750kW WTG Yaw bearing

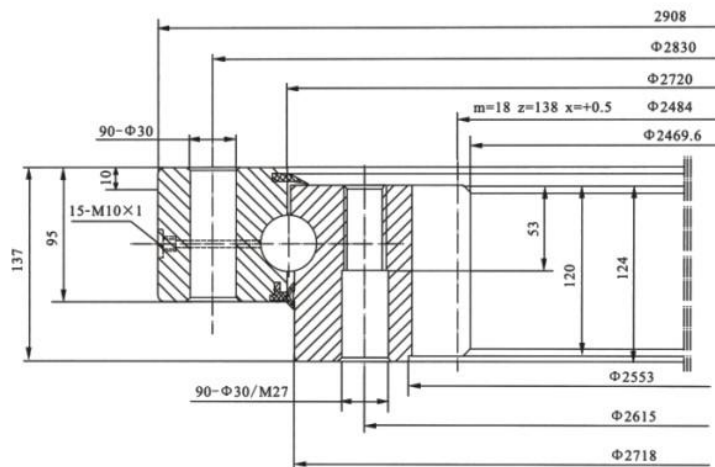

型号 Bearing Model	ZYS-013.40.2720.03
外型尺寸 Dimension	φ 2469.6 × φ 2908 × 137
轴承结构形式 Bearing Structure	单排四点接触球内齿式转盘轴承 Single-row four-point contact ball slewing bearing with internal gear
适用风机及部位 Application	1.5MW 风机 偏航轴承 1.5MW WTG Yaw bearing

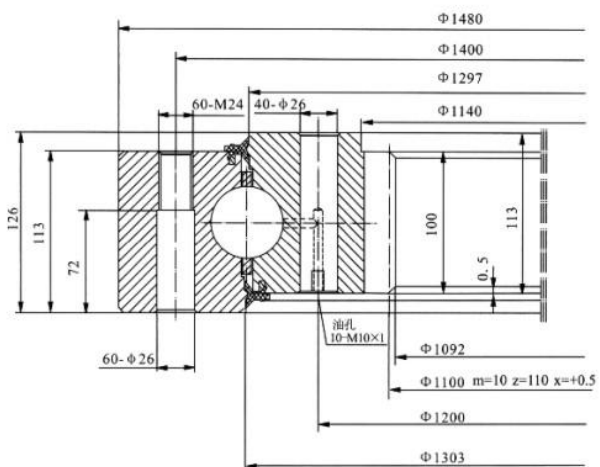

型号 Bearing Model	ZYS-013.50.1300.03
外型尺寸 Dimension	$\phi 1092 \times \phi 1480 \times 126$
轴承结构形式 Bearing Structure	单排四点接触球内齿式转盘轴承 Single-row four-point contact ball slewing bearing with internal gear
适用风机及部位 Application	900kW 风机 变桨轴承 900kW WTG Pitch bearing

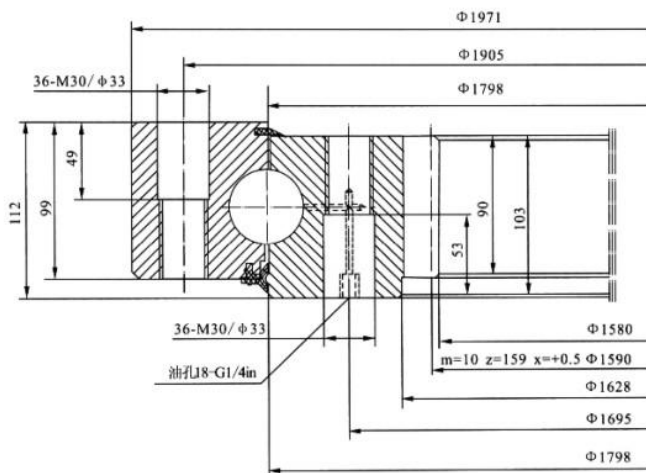

型号 Bearing Model	ZYS-013.50.1800.03
外型尺寸 Dimension	$\phi 1580 \times \phi 1971 \times 112$
轴承结构形式 Bearing Structure	单排四点接触球内齿式转盘轴承 Single-row four-point contact ball slewing bearing with internal gear
适用风机及部位 Application	800kW 风机 偏航轴承 800kW WTG Yaw bearing

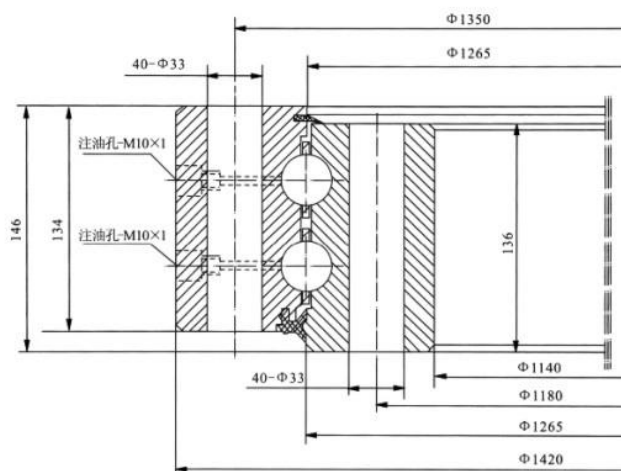

型号 Bearing Model	ZYS-030.30.1265.03
外型尺寸 Dimension	$\phi 1111 \times \phi 1420 \times 146$
轴承结构形式 Bearing Structure	双排同径球无齿式转盘轴承 Double-row ball slewing bearing without gear
适用风机及部位 Application	800kW 风机 变桨轴承 800kW Pitch bearing

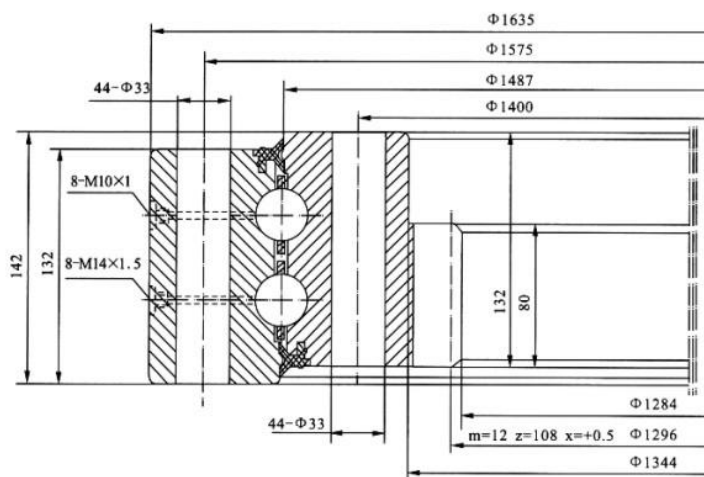

型号 Bearing Model	ZYS-033.30.1487.03
外型尺寸 Dimension	$\phi 1284 \times \phi 1635 \times 142$
轴承结构形式 Bearing Structure	双排同径球内齿式转盘轴承 Double-row ball slewing bearing with internal gear
适用风机及部位 Application	850kW 风机 变桨轴承 850kW WTG Pitch bearing

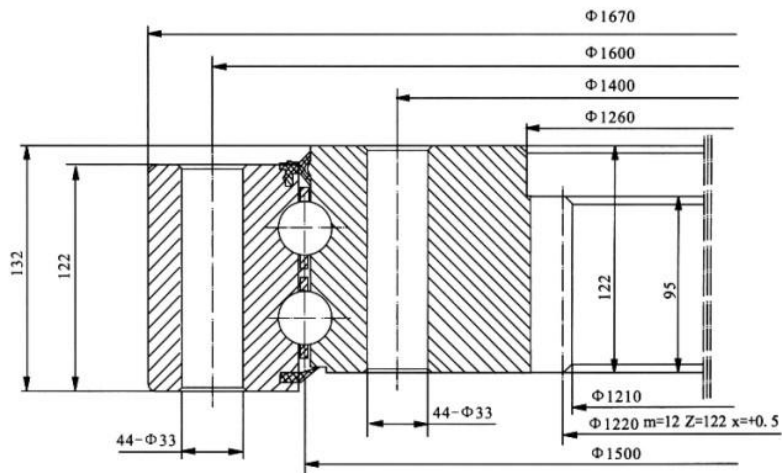

型号 Bearing Model	ZYS-033.30.1500.03
外型尺寸 Dimension	$\phi 1210 \times \phi 1670 \times 132$
轴承结构形式 Bearing Structure	双排同径球内齿式转盘轴承 Double-row ball slewing bearing with internal gear
适用风机及部位 Application	900KW 风机 变桨轴承 900kW WTG Pitch bearing

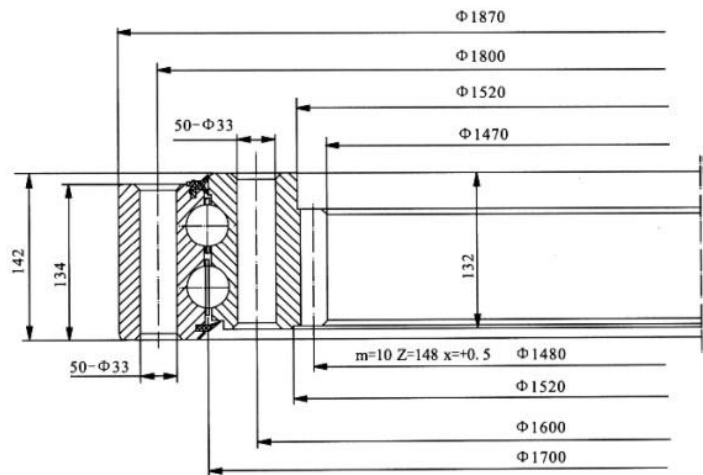

型号 Bearing Model	ZYS-033.30.1700.03
外型尺寸 Dimension	$\phi 1470 \times \phi 1870 \times 142$
轴承结构形式 Bearing Structure	双排同径球内齿式转盘轴承 Double-row ball slewing bearing with internal gear
适用风机及部位 Application	1.25MW 风机 变桨轴承 1.25MW WTG Pitch bearing

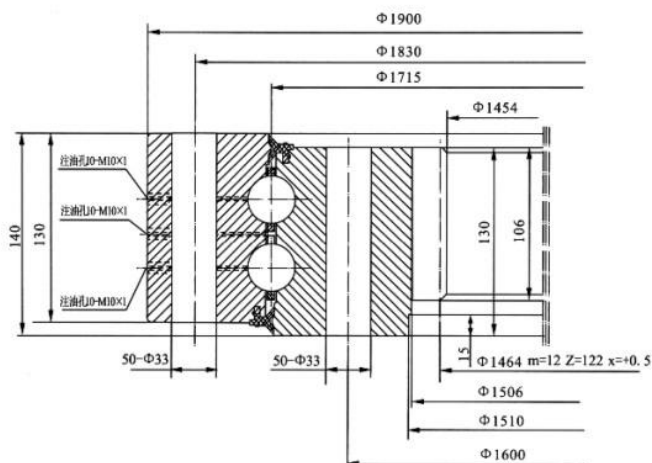

型号 Bearing Model	ZYS-033.30.1715.03
外型尺寸 Dimension	φ 1454 × φ 1900 × 140
轴承结构形式 Bearing Structure	双排同径球内齿式转盘轴承 Double-row ball slewing bearing with internal gear
适用风机及部位 Application	1.25MW风机 变桨轴承 1.25MW WTG Pitch bearing

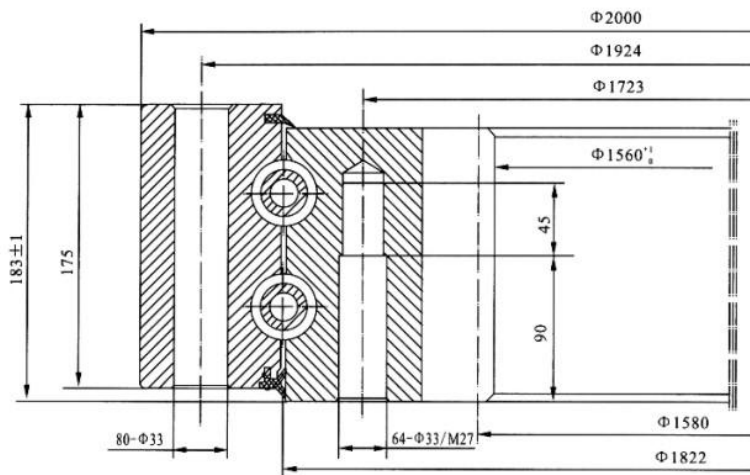

型号 Bearing Model	ZYS-033.40.1822.03
外型尺寸 Dimension	φ 1560 × φ 2000 × 183
轴承结构形式 Bearing Structure	双排同径球内齿式转盘轴承 Double-row ball slewing bearing with internal gear
适用风机及部位 Application	900kW风机 偏航轴承 900kW WTG Yaw bearing

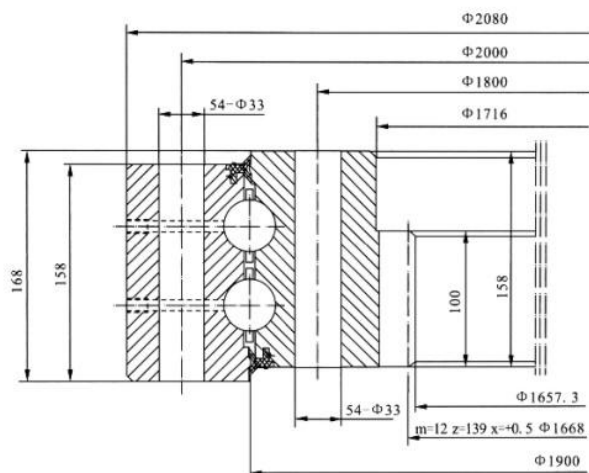

型号 Bearing Model	ZYS-033.40.1900.03
外型尺寸 Dimension	$\phi 1657.3 \times \phi 2080 \times 168$
轴承结构形式 Bearing Structure	双排同径球内齿式转盘轴承 Double-row ball slewing bearing with internal gear
适用风机及部位 Application	1.5MW风机 变桨轴承 1.5MW WTG Pitch bearing

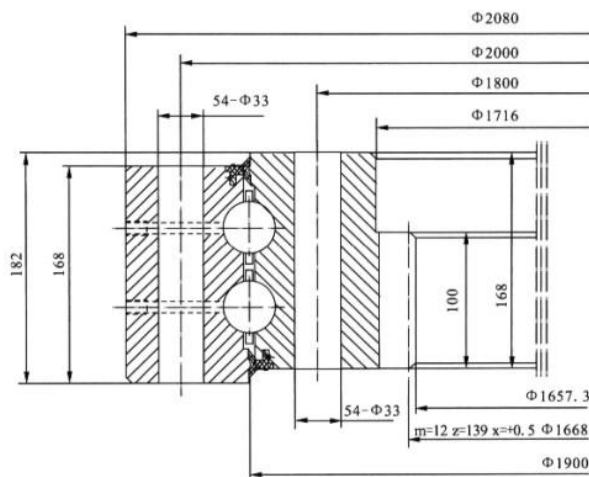

型号 Bearing Model	ZYS-033.40.1900.03K1
外型尺寸 Dimension	$\phi 1657.3 \times \phi 2080 \times 182$
轴承结构形式 Bearing Structure	双排同径球内齿式转盘轴承 Double-row ball slewing bearing with internal gear
适用风机及部位 Application	1.5MW风机 变桨轴承 1.5MW WTG Pitch bearing

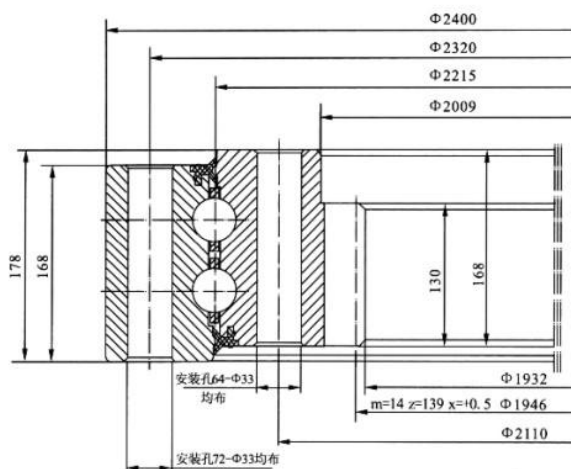

型号 Bearing Model	ZYS-033.45.2215.03
外型尺寸 Dimension	$\phi 1932 \times \phi 2400 \times 178$
轴承结构形式 Bearing Structure	双排同径球内齿式转盘轴承 Double-row ball slewing bearing with internal gear
适用风机及部位 Application	2MW风机 变桨轴承 2MW WTG Pitch bearing

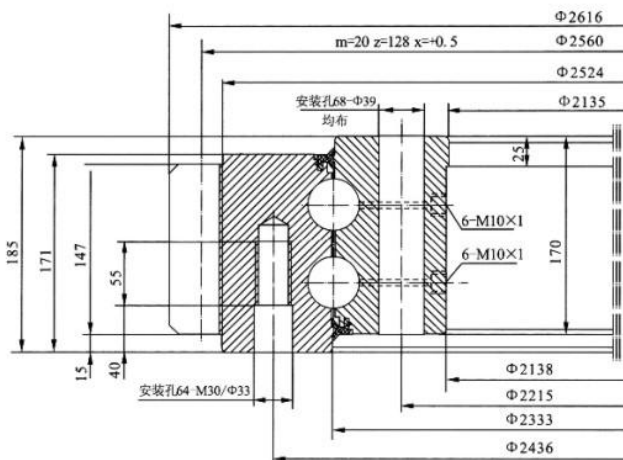

型号 Bearing Model	ZYS-032.45.2333.03
外型尺寸 Dimension	$\phi 2135 \times \phi 2618 \times 185$
轴承结构形式 Bearing Structure	双排同径球内齿式转盘轴承 Double-row ball slewing bearing with internal gear
适用风机及部位 Application	1.5MW风机 偏航轴承 1.5MW WTG Yaw bearing

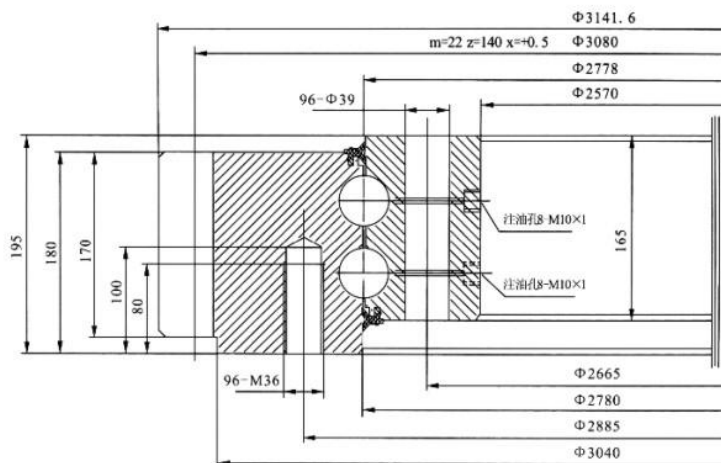

型号 Bearing Model	ZYS-032.45.2778.03
外型尺寸 Dimension	φ 2570 × φ 3141.6 × 195
轴承结构形式 Bearing Structure	双排同径球外齿式转盘轴承 Double-row ball slewing bearing with external gear
适用风机及部位 Application	3MW风机 偏航轴承 3MW WTG Pitch bearing

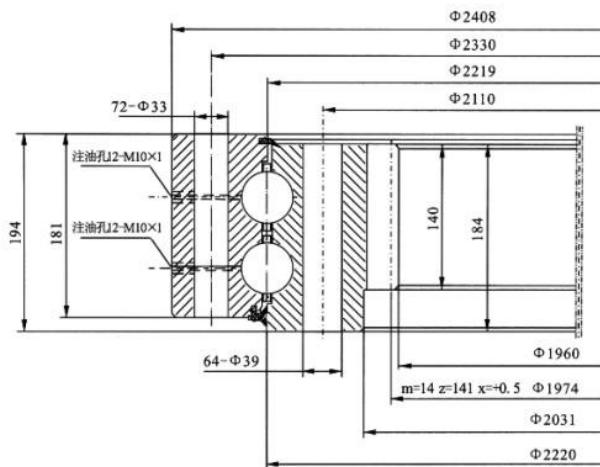

型号 Bearing Model	ZYS-033.50.2220.03
外型尺寸 Dimension	φ 1960 × φ 2408 × 194
轴承结构形式 Bearing Structure	双排同径球内齿式转盘轴承 Double-row ball slewing bearing with internal gear
适用风机及部位 Application	2MW风机 变桨轴承 2MW WTG Pitch bearing

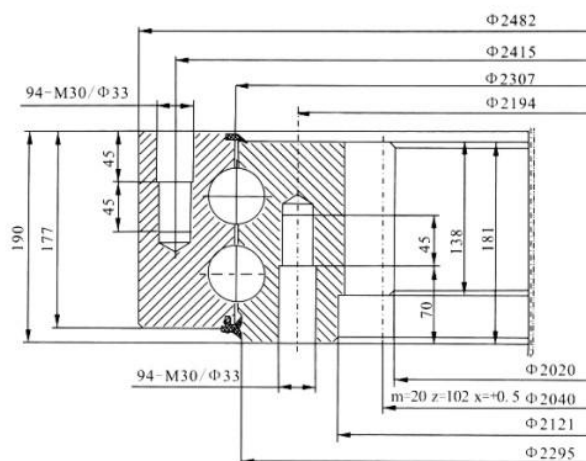

型号 Bearing Model	ZYS-033.50.2304.03
外型尺寸 Dimension	$\Phi 2020 \times \Phi 2482 \times 190$
轴承结构形式 Bearing Structure	双排同径球内齿式转盘轴承 Double-row ball slewing bearing with internal gear
适用风机及部位 Application	2MW风机 偏航轴承 2MW WTG Yaw bearing

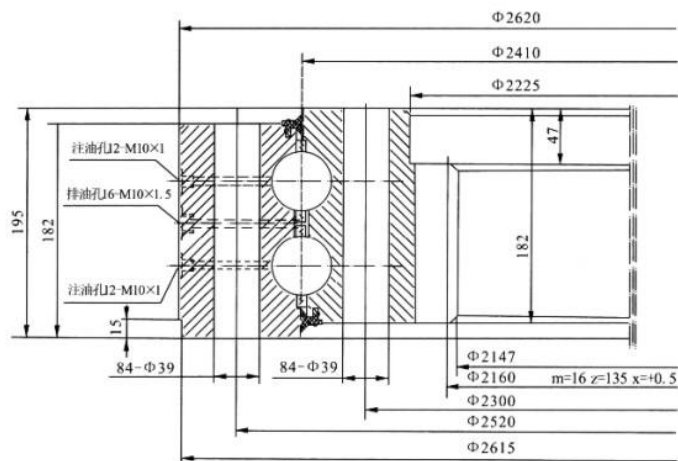

型号 Bearing Model	ZYS-033.50.2410.03
外型尺寸 Dimension	$\Phi 2147 \times \Phi 2620 \times 195$
轴承结构形式 Bearing Structure	双排同径球内齿式转盘轴承 Double-row ball slewing bearing with internal gear
适用风机及部位 Application	3MW风机 变桨轴承 3MW WTG Pitch bearing



## 六、齿轮箱轴承 Gearbox bearing

部分风力发电机齿轮箱轴承型号及适用机型  
The application of Gear Box Bearing in the wind generator

序号 Order	产品型号 Bearing Model	外型尺寸d×D×B Dimension d×D×B	结构形式 Structure	机型 WTG Model
1	NCF2888V/P5S0	φ 440 × φ 540 × 60	满装单列圆柱滚子轴承 single-row full complement cylindrical roller bearing	1.5MW增速机 1.5MW speed increaser
2	NCF18/530V/P5S0	φ 530 × φ 650 × 56		
3	NCF18/670V/P5S0	φ 670 × φ 820 × 69		
4	23060CA/SOW33	φ 300 × φ 460 × 118	调心滚子轴承 self-aligning roller bearing	1.5MW增速机 1.5MW speed increaser
5	22340CA/SOW33	φ 200 × φ 420 × 138		
6	NCF18/530V	φ 530 × φ 650 × 56	满装单列圆柱滚子轴承 single-row full complement cylindrical roller bearing	1.5MW增速机 1.5MW speed increaser
7	NCF28/670V	φ 670 × φ 820 × 88		
8	NNCF5044CV/C3	φ 220 × φ 340 × 160	满装双列圆柱滚子轴承 single-row full complement cylindrical roller bearing	1.5MW增速机 1.5MW speed increaser
9	NU1072EM	φ 360 × φ 540 × 82	单列圆柱滚子轴承 single-row cylindrical roller bearing	1.5MW增速机 1.5MW speed increaser
10	NU2326EM/C3	φ 130 × φ 280 × 93		
11	NU2336M/C3	φ 180 × φ 380 × 126		
12	NU2338EXM1/C3	φ 190 × φ 400 × 132		
13	NU326EM/C3	φ 130 × φ 280 × 58		
14	QJ326N2M	φ 130 × φ 280 × 58	四点接触球轴承 four-point contact ball bearing	1.5MW增速机 1.5MW speed increaser
15	QJ334N2M	φ 170 × φ 360 × 72		
16	Z-535808/DF	φ 400 × φ 540 × 86	成对单列圆锥滚子轴承 paired single-row tapered roller bearing	1.5MW增速机 1.5MW speed increaser
17	NU226EM	φ 130 × φ 230 × 40	单列圆柱滚子轴承 single-row cylindrical roller bearing	1.5MW增速机 1.5MW speed increaser
18	FD-NCF18/710V	φ 710 × φ 870 × 74	满装单列圆柱滚子轴承 single-row full complement cylindrical roller bearing	2MW增速机 2MW speed increaser
19	FD-NCF18/560V	φ 560 × φ 680 × 56		

序号 Order	产品型号 Bearing Model	外型尺寸d×D×B Dimension d×D×B	结构形式 Structure	机型 WTG Model
20	FD-NJG2344VH	φ 220 × φ 460 × 145	满装单列圆柱滚子轴承 single-row full complement cylindrical roller bearing	2MW增速机 2MW speed increaser
21	FD-NU1088EM	φ 440 × φ 650 × 94	单列圆柱滚子轴承 single-row cylindrical roller bearing	2MW增速机 2MW speed increaser
22	FD-31088X2-1/DF	φ 440 × φ 650 × (96 × 2)	成对单列圆锥滚子轴承 paired single-row tapered roller bearing	2MW增速机 2MW speed increaser
23	FD-NU2344EM	φ 220 × φ 460 × 145	单列圆柱滚子轴承 single-row cylindrical roller bearing	2MW增速机 2MW speed increaser
24	FD-30344/DF	φ 220 × φ 460 × (97 × 2)	成对单列圆锥滚子轴承 paired single-row tapered roller bearing	2MW增速机 2MW speed increaser
25	FD-NU224EM	φ 120 × φ 215 × 40	单列圆柱滚子轴承 single-row cylindrical roller bearing	2MW增速机 2MW speed increaser
26	NNCF5060V/P53 DR S0	φ 300 × φ 460 × 218	成对用满装双列圆柱滚子轴承 paired full complement double-row cylindrical roller bearing	3MW齿轮箱 3MW gearbox
27	NCF18/800V/P53 CNL S0	φ 800 × φ 980 × 82	满装单列圆柱滚子轴承 single-row full complement cylindrical roller bearing	3MW齿轮箱 3MW gearbox
28	NJ2334EM/P53 DB S0	φ 170 × φ 360 × 120	成对用单列圆柱滚子轴承 paired single-row cylindrical roller bearing	3MW齿轮箱 3MW gearbox
29	306/500/P5 S0	φ 500 × φ 670 × 85	单列圆锥滚子轴承 single-row tapered roller bearing	3MW齿轮箱 3MW gearbox



## 七、主轴轴承 Spindle bearing

部分风力发电机齿轮箱轴承型号及适用机型  
The application of Gear Box Bearing in the wind generator

序号 Order	产品型号 Bearing Model	外型尺寸d×D×B Dimension d×D×B	结构形式 Structure	机型 WTG Model
1	ZYS-SP001	φ 1315 × φ 1725 × 262	无齿三排圆柱滚子转盘轴承 Three-row cylindrical roller slewing bearing without gear	750KW
2	240/800CAP6/W33	φ 800 × φ 1150 × 345	调心滚子轴承 self-aligning roller bearing	1.5MW
3	240/630CA/W33	φ 630 × φ 920 × 290		1.25MW
4	3519/800X2	φ 800 × φ 1060 × 285	双列圆锥滚子轴承 double-row tapered roller bearing	1.5MW
5	3519/710X2	φ 710 × φ 950 × 248		
6	230/800/W26	φ 800 × φ 1150 × 258	调心滚子轴承 self-aligning roller bearing	1.5MW
7	240/630 CA/W33	φ 630 × φ 920 × 290		
8	239/670 CA/W33	φ 670 × φ 900 × 170		
9	240/530 CA/W33	φ 530 × φ 780 × 250		
10	240/600 CA/W33S0	φ 600 × φ 870 × 272		
11	NU19/1250	φ 1250 × φ 1630 × 170	单列圆柱滚子轴承 single-row cylindrical roller bearing	1.5MW
12	3519/950	φ 950 × φ 1250 × 300	双列圆锥滚子轴承 double-row tapered roller bearing	1.5MW
13	230/710 CA/W33	φ 710 × φ 1030 × 236	调心滚子轴承 self-aligning roller bearing	2MW
14	241/600 CA/W33	φ 600 × φ 980 × 375		
15	N6/1200/W26	φ 1200 × φ 1520 × 185	单列圆柱滚子轴承 single-row cylindrical roller bearing	1.5MW
16	ZYS-3010	φ 1370 × φ 1780 × 276	双列圆锥滚子轴承 double-row tapered roller bearing	1.5MW

## 八、用户调查表 Application questionnaire

应用 Application	
旋转轴位置：用度表示 Axis of rotation (Unit: Degree)	
安装位置 Mounting position	平置 <input type="checkbox"/> Horizontal    倾挂式 <input type="checkbox"/> Suspend    垂直 <input type="checkbox"/> Vertical
发动机个数 Number of motors	
发动机安装在臂杆上位置：度 Position of motor installation position on lever (Unit: Degree)	

## 载荷 Load

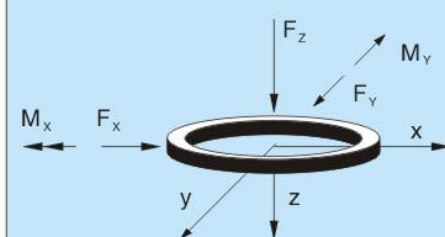
	1	2	3	4
	正常工作载荷 Operating load	最大工作载荷 Max. working load	试验载荷 Testing load	极限载荷 (非工作载荷) Extreme load (out of operation)
轴向力Fz KN Axial force Fz				
径向力Fx KN Radial force Fx				
径向力Fy KN Radial force Fy				
力矩Mx KNm Moment Mx				
力矩My KNm Moment My				
承载集合运行时间比例 百分比 Load percentage Ratio Percentage				

## 运行条件 Operating condition

尘埃、水份、海水、化学物质的影响及其它 Environment (dust, water, seawater, chemical substances, and etc)	
运行温度 Operating temperature	℃
运行时间 Working time	小时/天 hour/day
回转运行的实际时间 Rotation time	%
回转交换次数 Oscillating frequency	1/小时 1/hour
每次工作交换的平均回转角度 Mean rotating degree each oscillating movement	度 Degree